



Catalog 860-10

## Self-Contained Air Conditioning Systems

Type SWP  
Vintage H  
R-410A Refrigerant  
23 to 130 Tons



People and ideas you can trust.™

<b>Introduction</b> . . . . .	<b>3</b>	<b>Application Considerations</b> . . . . .	<b>23</b>
Continued Leadership in Self-Contained Systems Designs . . . . .	3	General . . . . .	23
<b>Features and Benefits</b> . . . . .	<b>4</b>	Unit Location . . . . .	23
SWP 012–130 Features and Options . . . . .	4	Acoustical Considerations . . . . .	24
Cabinet, Casing and Frame . . . . .	6	Condenser Water Piping . . . . .	25
Compressor/Condensing Section . . . . .	7	Head Pressure Control . . . . .	25
Cooling Coil Section . . . . .	8	Variable Air Volume . . . . .	25
Supply Fan Section . . . . .	8	Variable Frequency Drives . . . . .	26
Acoustical Advantages . . . . .	9	Duct Static Pressure Sensor Placement . . . . .	26
Acoustical Discharge Plenum . . . . .	9	Zone Sensor Placement . . . . .	26
Variable Air Volume Control . . . . .	10	Filtration . . . . .	26
Economizer Options . . . . .	10	System Operating Limits . . . . .	27
Filter Section . . . . .	11	<b>Selection Procedure</b> . . . . .	<b>29</b>
Blank Sections . . . . .	11	<b>Physical Data</b> . . . . .	<b>31</b>
Electrical . . . . .	12	Unit Weights . . . . .	36
Heating Section . . . . .	12	<b>Performance Data</b> . . . . .	<b>39</b>
System Flexibility with Unit Options . . . . .	13	DX Cooling Capacity Data . . . . .	39
Controllers . . . . .	14	Waterside Economizer Capacity . . . . .	46
R-410A Refrigerant . . . . .	14	Heating Capacity Data . . . . .	49
<b>MicroTech III Unit Controls</b> . . . . .	<b>15</b>	Component Pressure Drops . . . . .	50
Components . . . . .	15	Total Unit Water Pressure Drop . . . . .	52
Alarm Management and Control . . . . .	22	Fan Curves . . . . .	57
		<b>Dimensional Data</b> . . . . .	<b>64</b>
		Recommended Clearances . . . . .	64
		<b>Electrical Data</b> . . . . .	<b>69</b>
		<b>Engineering Guide Specifications</b> . . . . .	<b>70</b>

## Continued Leadership in Self-Contained Systems Designs

Daikin SWP self contained air conditioning systems trace their history to the late 1970s. The first self contained variable air volume systems with waterside economizer cycle was developed by us for the prestigious 499 Park Avenue office building in New York City. Daikin SWP, with decades of innovation, design flexibility, durable construction, low capitol and operating cost, make us the leader of self contained system market and the preferred HVAC solution for thousand of most prominent building projects.

SWP water cooled self-contained air conditioner is an ideal option for a job where energy efficiency, reliability, indoor air quality and acoustic are top priorities. Along with providing high quality and state-of-the-art technology, SWP self-contained systems offer the following valuable features and benefits to satisfy a wide range of diverse applications.

- Comfort and Redundancy
  - Occupants enjoy individual control over comfort conditions and off-hour system operation
  - Tenants benefit from their individual efforts to control energy costs
  - Routine service is located where it minimizes tenant inconvenience
  - Individual or dual systems per floor provide system redundancy and standby
  - Economical First Cost
  - VAV system flexibility uses building diversity to reduce system tonnage and first cost
  - Factory-packaged concept reduces field labor, installation time and expense
  - No expensive chilled water piping or chiller room
  - Individually tested, factory-designed systems reduce startup and installation expense
  - Reduced penthouse and equipment room requirements
  - Centralized condenser water and condensate piping and streamlined system layout
  - Modular units design make renovation projects easier since individual section designed for narrow hallways, elevators and doorways
  - Optional acoustical discharge plenum is an available option in any height to match your job needs and minimizes supply duct transition losses
  - Energy Efficient System
  - Reduces fan kW and operating costs at part load conditions
  - Savings maximized through use of variable speed fan control
  - Individual zone control
- Improving Indoor Air Quality
  - For better filtration filter selection flexibility includes:
    - MERV 7, 8, 11, 13, or 14 options with & without pre-filter. Microbial-resistant filter option is also an available option
    - Featured Double-wall panel construction that eliminates fibers in the supply air stream and is easy to clean
    - Provided with double-sloped, galvanized or stainless steel drain pans eliminate stagnant water and minimizes bacterial growth
    - Quiet System Operation
    - Provided by structural quality and specialized design
    - Recognized for quiet operation by renowned U.S. acoustical consultants
    - Provided with a SWSI airfoil plenum fan for excellent acoustics and better efficiency
    - Unit featured discharge plenum with sound baffles is an available option for sound sensitive job
- Free Cooling
  - Water or air economizer capability for optimized energy savings
  - Economizer reduces compressor operating hours and energy costs
  - Year-round “free cooling” capability
  - Efficient Part Load Operation
  - System energy at part load operation is more efficient than to central chilled water systems
  - Multiple systems and compressors versus a single, large central plant
  - Efficient and reliable system for partial occupancy and after hours operation
  - Operates only the system(s) on the floor(s) requiring after hours use
  - Economical Integrated or Stand Alone DDC controls
  - Monitoring and diagnostics reduce the potential for expensive field repairs
  - Industry leading Protocol Selectability™ feature provides effective BAS selection flexibility
  - Maintenance Costs Reduction
  - No complicated central chiller plant to maintain
  - Service and maintenance are performed out of the occupied space
  - Control and product reliability functions designed by the equipment manufacturer for single source responsibility and improved reliability
  - System Versatility
    - Applicable to schools, offices, shopping centers, manufacturing facilities, etc
    - Prime candidate for floor by floor building renovation
    - Retrofit alternative where existing chiller cannot be accessed for replacement

## SWP 023–130 Features and Options

### 1 Airfoil Plenum Fans

- SWSI fans more energy efficient and quieter than forward curved fans
- Premium high efficiency open, drip-proof standard motors and TEFC motors, an available option
- Seismic control restrained spring isolators are available
- Aerodynamically designed fan also available with 12 blades for even lower sound levels

### 2 Coils

- High efficiency enhanced corrugated fin design
- High coil performance and reduced static pressure losses
- Interlaced and/or row split circuiting to keep full face of the coil active and to eliminate air temperature stratification and optimum part load performance

### 3 Durable Construction

- Pre-painted or G90 galvanized steel exterior cabinet panels
- Standard foam injected panels with R-13 insulation provide superior rigid double wall construction and minimizes air leakage
- For better acoustics, an additional 2", 1.5# density R-8 fiberglass insulation is an available option for fan and plenum sections
- Double-sloped drain pans help eliminates standing stagnant water

### 4 Blank Sections

- Available to mount air blenders, carbon or charcoal filters, sound attenuators or other specialty equipment
- Allow customization for maximum system performance and efficiency
- Can reduce design and installation costs
- Refer to Sales and Engineering Data Sheet, ED 19061

### 5 Scroll Compressor(s)

- Durable and reliable multiple compressors
- Lower operating cost with High EERs
- Customize selections to match specific application
- Mounted on resilient rubber isolation for smooth and quiet operation

### 6 Access Panels and Doors

- All panels and access doors shall be sealed with permanently applied bulb-type gasket
- Access doors are flush mounted to cabinetry, with hinges, latch and handle assembly





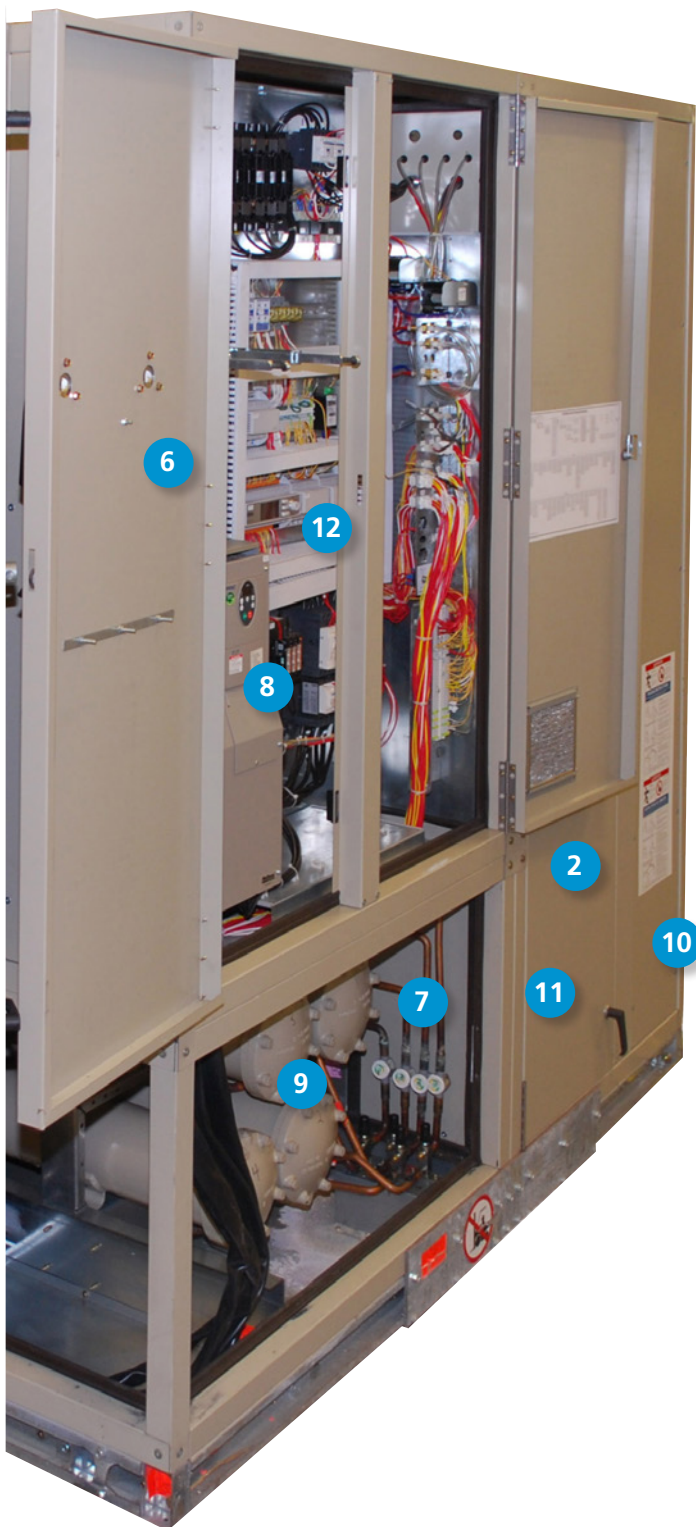

- 7 Refrigerant Circuits**
  - Suction and discharge service valves, an available option, to isolate each compressor
  - Hot gas bypass, an available option
  
- 8 Factory-Mounted Variable Frequency Drives**
  - Controlling fan motor speed can lower fan operating costs and sound levels
  - All VFD selections are plenum rated
  - Manually activated bypass contactor is available to allow system operation in the event of drive service
  
- 9 Shell and Tube Condensers**
  - Carbon steel Shell and Tube Condenser , nonferrous water channels and enhanced tubing for high performance
  - Integral sub-cooling circuit is provided as standard to maximize efficiency
  - Mechanically cleanable condenser and water piping is rated for standard 300 psig waterside working pressure & 450 psig is an available option
  - Two-way valve for head pressure control is available for low condenser water temperatures
  
- 10 Multiple Filter Options**
  - 2" 30% (MERV7) and 75% (MERV13) filters
  - 4" 30% (MERV8), 65% (MERV11), 75% (MERV13) and 85% (MERV14) longer lasting filters available
  - 4" primary filters also available with 2" or 4" with pre-filter
  
- 11 Economizer Options**
  - Waterside economizer effectively uses low cooling tower water temperatures to offload compressor operation
  - An airside economizer control package is available for controlling field installed mixing dampers capable of 100% outside airflow
  
- 12 MicroTech® III Control System**
  - Factory-installed and tested to help minimize costly field commissioning
  - Open Choices™ feature for easy integration into the BAS of your choice using open, standard protocols such as BACnet® or LONTALK®
  - Easily accessed for system diagnostics and adjustments via a keypad/display on unit
  - Optionally add a remote keypad and display that is identical to the unit mounted user interface

Daikin Self-Contained SWP systems are built to perform, with features and options that provide for lower installed and operating costs, good indoor air quality, quiet operation and longevity.

## Cabinet, Casing and Frame

- Unit base constructed of 15-gauge and 10-gauge galvanized steel for vibration control and rigging strength
- Heavy-duty lifting brackets strategically placed for balanced cable or chain hook lifting
- Low leak gasketed frame channels minimize air leakage and eliminates metal-to-metal contact between paneling and frame work. Air leakage is only 0.5 cfm/square foot at 5" cabinet pressure
- Unit cabinet constructed with foam insulation standard and heavy gauge pre-painted exterior panels for long equipment life
- All sections have galvanized steel internal lining
- 2-inch thick panels and access doors are thermal broke double wall assembly, with [R-13 foam] [R-8 fiberglass]
- System components strategically located for ease of inspection, serviceability and maintenance
- Refrigeration components positioned out of the airstream so adjustments and readings can be made without disrupting system operation
- Access doors flush mounted to cabinetry, with hinges, latch and handle assembly
- Doors on positive pressure sections are provided with secondary latches to relieve pressure and prevent injury upon access

## Modular Design

- Optional modular construction unit shipped with a nitrogen holding charge
- Four distinct sections; coil/access section, supply fan section, compressor/condenser section and the control panel

**Figure 1: Low Leak Gasketed Frame and Foam Panels**

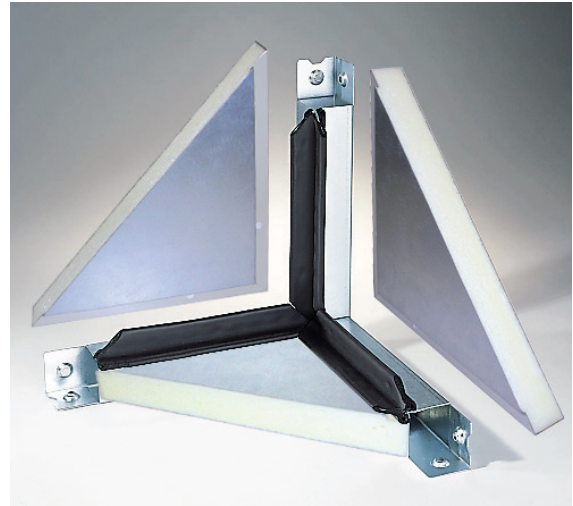

**Figure 2: Hinged Access Doors with double latches**



**Figure 3: SWP Modular Sections**

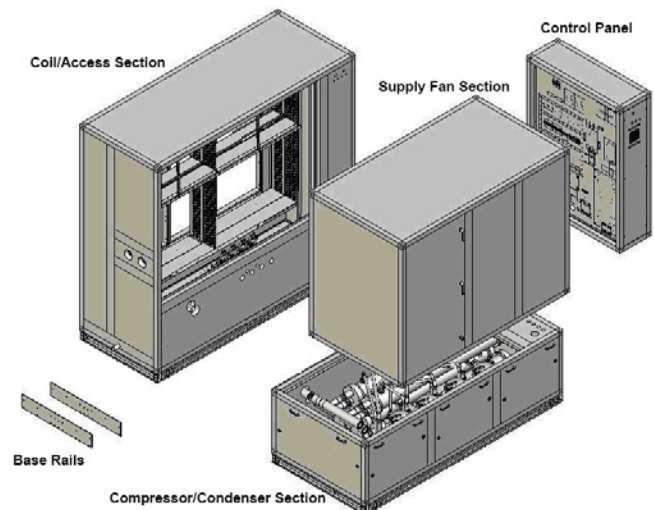

## Compressor/Condensing Section

### Compressors

- All units feature multiple reliable scroll compressors for efficient system part load control, quiet operation and system redundancy
- Suction and discharge service valves and gauge ports, available option, on each compressor
- Individual branch circuit fusing protects each compressor
- To prevent compressor short cycling, MicroTech® III control system incorporates timing functions
- Compressors mounted on resilient rubber isolation for smooth and quiet operation
- Insulated and segregated condensing section from the air handling section to avoid transmission of noise to the circulated air stream
- Each refrigerant circuit is furnished with filter-drier, liquid moisture indicator/sight glass, thermal expansion valve, liquid line shutoff valve with charging port, high pressure relief device and high and low pressure cutouts
- If any compressor is made inoperable, the remaining compressors are still allowed to operate
- Thermal expansion valve capable of modulation from 10025% of its rated capacity
- Hot gas bypass also available on units with two refrigerant circuits

**Figure 4: Compressors**



### Condensers

- All units feature carbon steel mechanically cleanable shell and tube condenser
- Includes non-ferrous water channels and enhanced tubing for high performance
- Serves an independent refrigerant circuit and includes a spring loaded high pressure relief valve
- Integral sub-cooling circuit provided as standard to maximize efficiency
- All units are leak tested, evacuated and shipped with a [full operating charge of R-410A] [for modular design nitrogen holding charge] and POE oil
- Condenser assembly and all factory water piping rated for a waterside working pressure of 300 psig as standard [450 psig] tested before shipment
- Provided with a single supply and return water connections
- Unit available in both right-hand and left-hand piping locations
- Optional two-way valve provides accurate head pressure control for condenser entering water temperatures as low as 40°F

**Figure 5: Condensers**





### Cooling Coil Section

- Large face area coils with high efficiency, enhanced copper tubing and ripple corrugated aluminum fins
- Features interlaced and/or row split circuiting to keep the full face of the coil active and eliminate air temperature stratification and optimum part load performance
- 5 or 6 row evaporator coil with 12 fins/ inch spacing and multiple face areas allows a custom match to specific design loads
- Provides low air pressure drop, high full and part load operating efficiencies
- Mounted in a [galvanized] [stainless steel ] cross broke and double sloped drain pan with a full 2 inches of insulation
- Compressor staging sequenced to take maximum advantage of available coil surface
- Each evaporator coil circuit furnished with a wide range thermostatic expansion valve with an adjustable superheat setting and external equalizer
- An intermediate drain pan in the coil bank helps to provide condensate removal without carryover

**Figure 6: Evaporator Coil Circuiting**

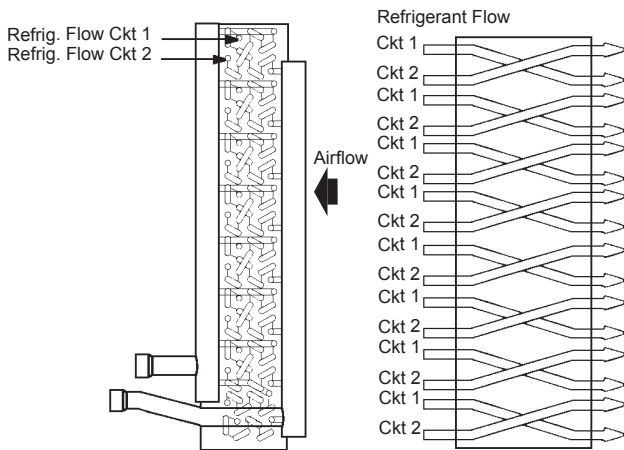

**Figure 7: Cooling Coil Section Shown**

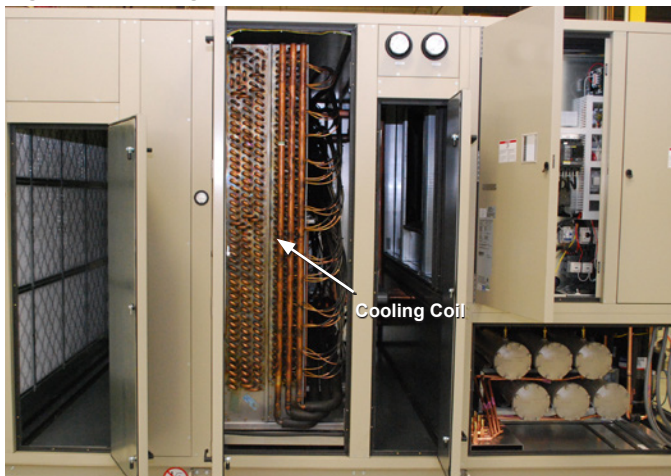

### Supply Fan Section

- Single width, single inlet (SWSI) airfoil supply air fan selections provide efficient, quiet operation at wide ranging static pressure and air flow requirements
- Each fan assembly is dynamically trim balanced at the factory for quiet operation before shipment
- All fan drives are factory sized according to job specific airflow, static pressure, and power requirements
- For seismic sensitive regions, spring fan isolators are available with seismic restraints
- 150% service factor drives extend service life of the fan belts. Drive components and fan bearings are easily accessed for periodic maintenance
- Mounted on 2 inch deflection spring isolators for excellent isolation effectiveness
- Solid steel shafts rotating in 200,000 hour pillow block ball bearings with grease fittings
- Motor availability includes premium efficiency, open, drip-proof, and totally enclosed selections; EPACT compliant premium efficiency selections

**Figure 8: Airfoil Fan**

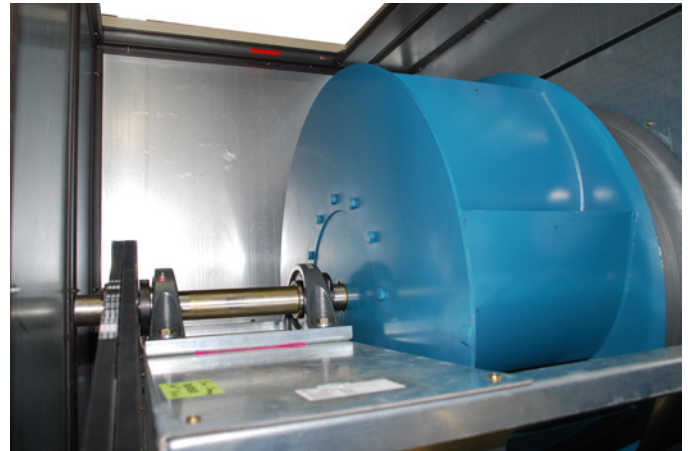



## Acoustical Advantages

Daikin SWP Self-contained units are provided with a high efficient, SWSI airfoil plenum fan and have several acoustical advantages:

- Airfoil fans are more efficient than forward curved fans contributing to less noise
- For specific unit sizes, several fan diameters are available, fan selection provides optimal efficiency
- Competitive supply duct work normally involves discharging air vertically into a ceiling, then routing it horizontally, [Figure 9](#). Daikin's plenum fan discharge has far less velocity pressure than competitive housed fan discharge, resulting in:
  - 90° duct elbows that generate far less turbulence
  - Air flow that can be routed in any direction

**Figure 9: Supply Fan Comparison**

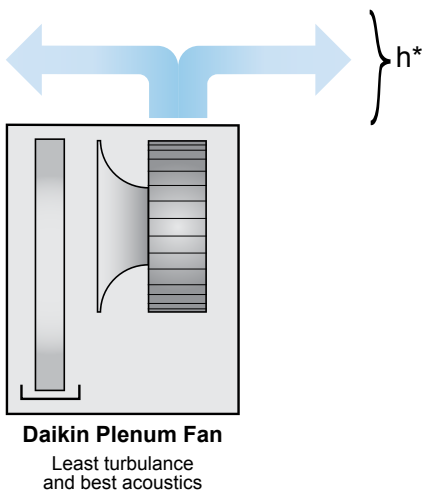
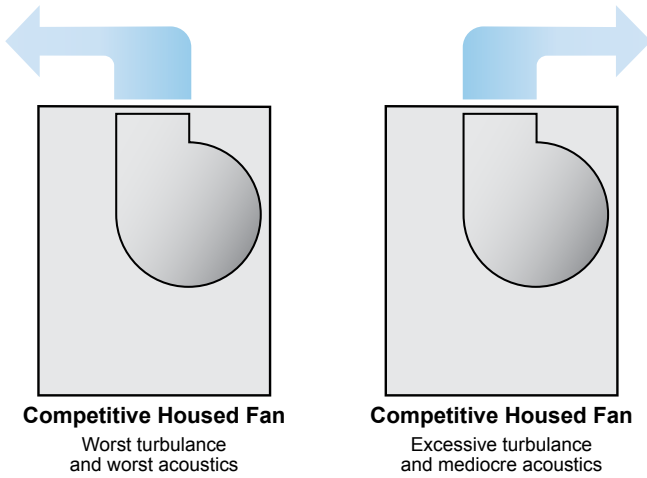

\* Ceiling heights restrict "h" and increase the problem with housed fans

## Acoustical Discharge Plenum

Daikin offers an optional acoustical discharge plenum, [Figure 10](#), that minimizes supply duct transition losses and noise:

- Plenum fans pressurize the entire cabinet and have no significant plenum air pressure drop (housed fans have expansion, contraction and 90° elbow losses)
- Discharge plenums offered in any height to match ceiling height
- Custom size duct connections are available on any size plenum

**Figure 10: Acoustical Discharge Plenum**

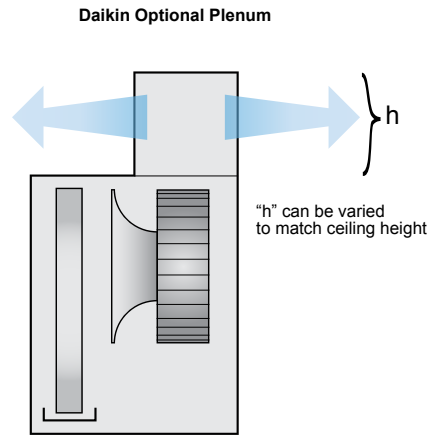

## Discharge Plenum with Foam Insulation and Sound Baffles

Optional discharge plenum with foam injected panels can be provided with the additional sound attenuating baffle option consisting of:

- Additional 2" of fiberglass insulation
- Perforated liners, [Figure 11](#)

**Figure 11: Foam Insulation and Sound Baffles**

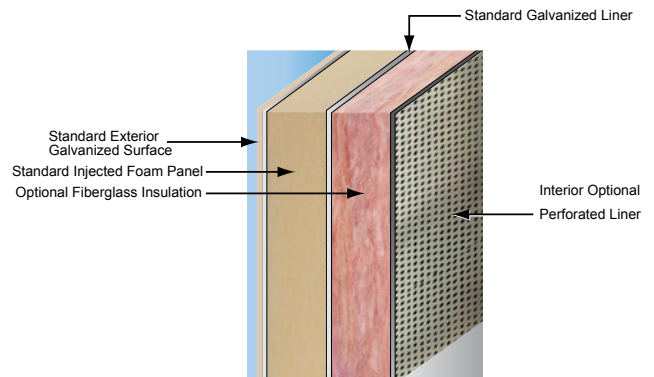

## Variable Air Volume Control

- Energy saving advanced technology variable frequency drive (VFD), fan speed control is available with the convenience and cost savings of factory mounting and testing
- All VFD selections are plenum rated and are conveniently mounted within the control panel
- MicroTech III controls provide advanced duct static pressure control and controlled by either single or two-duct static pressure sensors
- A manually activated bypass contactor is available to allow system operation even in the event of drive service
- All VAV systems include an adjustable, duct high-limit switch to protect duct work from excessive pressure

**Figure 12: Variable Frequency Drive Controller**



## Economizer Options

### **Waterside Economizer**

- An energy saving, waterside economizer package, an available option on all return air unit
- Includes factory mounted 4-row [chemically cleanable coil] [mechanically cleanable coil], control valves and piping
- Rated for 300 psig as standard [450 psig] waterside working pressure and the entire coil and piping assembly is factory leak tested
- Factory integrated MicroTech III controller to control economizer operation and maximize free cooling potential
- Unit enables economizer operation whenever cooling tower water temperature is less than the unit entering air temperature by a field adjustable value, generally 5-7°F
- To save energy with a variable pumping system control valves operation can be selected to maintain full flow through the unit at all times or to isolate the unit from the condenser water loop when there is no call for cooling
- To extend free cooling savings, economizer operation can be enabled during mechanical cooling
- Unit enables mechanical cooling only when the economizer valve is driven 90% open and cooling load is not satisfied
- Economizer control will maintain full free cooling capability until disabled by the economizer changeover set point
- To help protect against coil freeze-up an optional factory mounted freeze stat is available

**Figure 13: Mechanically Cleanable Waterside Economizer Coil**

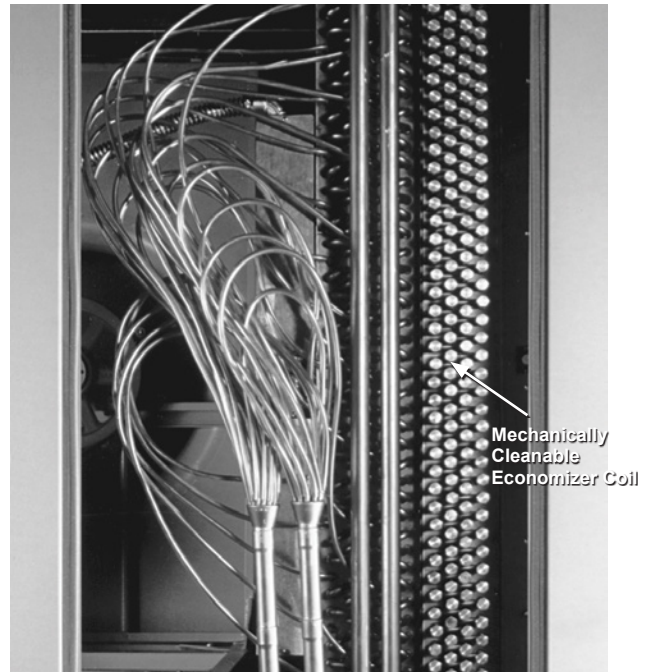

### ***Airside Economizer***

- A mixing box containing outdoor air, return air and exhaust air dampers are available using the Daikin Vision™ air handling unit platform
- Factory integrated MicroTech III controller controls economizer operation and maximize free cooling potential
- Airside economizer control package available to control field installed mixing dampers capable of 100% outside airflow
- Unit enables economizer operation whenever outside air enthalpy, comparative enthalpy or dry bulb temperature changeover provides control flexibility to bring in most amount of outside air for free cooling
- Economizer damper control actuator modulates in response to the cooling load
- MicroTech III controller positions outside air damper to maintain minimum ventilation requirements when economizer is not in operation
- To extend free cooling savings, economizer operation can be enabled during mechanical cooling
- Unit enables mechanical cooling only when the economizer damper is driven 90% open and cooling load is not satisfied
- Economizer control will maintain full free cooling capability until disabled by the economizer changeover set point

### ***Condenser Head Pressure Control***

- Unit requires condenser head pressure control for applications where a waterside economizer package is not being used and entering condenser water temperatures can be less than 55°F
- Optional two-way valve provides accurate head pressure control for condenser entering water temperatures as low as 40°F

### **Filter Section**

- Selection flexibility includes face loaded rack with nongasketed frames and filter clips
- Unit features 2-inch filter option available in 30% (MERV 7) & 75% (MERV 13) nominal efficiency
- Longer lasting 4-inch filters higher filtration option is available in 30% (MERV 8) & 65% (MERV 11), 75% (MERV 13) & 85% (MERV 14) nominal efficiency with and without 2-inch or 4-inch 30% pre-filter

**Figure 14: 4 Inch Filters**

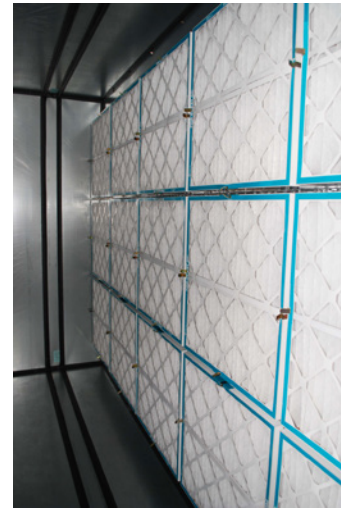

### **Blank Sections**

- Available to mount air blenders, pre-heat coils, sound attenuators or other specialty equipment using the Daikin Vision™ air handling unit platform and shipped loose
- Allow customization for maximum system performance and efficiency and reduce design and installation costs
- Refer to Sales and Engineering Data Sheet, ED 19061

## Electrical

- Units are completely wired and tested at the factory prior shipment
- Wiring complies with NEC requirements and all applicable UL standards
- For ease of use, wiring and electrical components are number coded and labeled according to the electrical diagram whenever applicable
- Supply air fan motors, compressor motors and electric heat all branch circuits have individual short circuit protection
- Control circuit power is supplied through a factory installed, low voltage transformer
- The supply fan motor circuit includes a three phase contactor and ambient compensated overload protection with manual reset
- Each refrigerant circuit includes both a high and low pressure cutout switch
- A terminal block is provided for the single, main power connection and a terminal board is provided for low voltage control wiring
- A factory mounted, non-fused main circuit interrupter is available for disconnecting the main electrical power to the unit
- Dual power blocks or disconnect switches are available to accommodate requirements for standby, emergency power supplies

## Heating Section

### *Hot Water Heat*

- Multiple coil selections offered to size heating output to application needs
- Hot water coils are 5/8-in. O.D. copper tube/ aluminum fin design with patented HI-F5 fins
- Rated in accordance with ARI Standard 430
- Pre-heating control fully integrated into the unit's MicroTech III control system is available using the Daikin Vision™ air handling unit platform
- Available with factory-mounted freezestat

### *Steam Heat*

- Steam heating coils are 5/8-in. O.D. copper tube/ aluminum fin jet distributing type with patented HI-F5 fin design
- Rated in accordance with ARI Standard 430
- Multiple different steam coil selections offered to size heating output to application needs
- Pre-heating control fully integrated into the unit's MicroTech III control system is available using the Daikin Vision™ air handling unit platform
- Available with factory-mounted freezestat

### *Electric Heat*

- Factory assembled, installed and tested
- Two stage capability for application flexibility
- Durable low watt density nickel chromium elements for longer life
- Entire heat bank protected by a linear high limit control with each heater element protected by an automatic reset high limit control
- Fuses provided in each branch circuit



## System Flexibility with Unit Options

Along with providing high quality and state-of-the-art innovation, SWP self-contained systems offer customized flexibility to satisfy a wide range of diverse applications.

### **Selection/Application Flexibility**

Nominal cooling capacities range from 12 to 130 tons. In addition, all units offer multiple compressor selections to meet exacting system requirements. The flexibility to optimize the self-contained system to fit the application is a McQuay SWP advantage. Available system applications include the following:

- VAV discharge air temperature control with static pressure control
- Discharge air temperature control with constant air volume
- Constant volume, zone temperature control
- 100% outside air control
- Dehumidification control, with or without reheat control. In addition to compressor/coil flexibility, SWP systems offer single width, single inlet, air foil fans with factory-mounted variable frequency drives for maximizing VAV system fan performance. High efficiency fan capability coupled with extensive compressor flexibility provide the right system selection for the application

### **Arrangement Flexibility**

All SWP systems offer the flexibility of right-hand and left-hand piping and control panel arrangements and multiple fan discharge orientations. Piping and fan arrangement flexibility can simplify mechanical equipment room arrangement, improve installation costs, and total system performance.

### **Optimal Discharge Air Temperature**

More and more system engineers are designing optimal discharge air temperature systems to improve system performance and system first cost; the Daikin SWP provides the flexibility to do it successfully. Optimal discharge air temperature systems are designed to provide unit leaving air temperature selections of 52°F to 53°F versus more conventional systems that supply air at temperatures closer to 58°F. This five to six degree reduction in air temperature to the room diffusers can subsequently reduce the required supply air volume to the room by 20% to 25%.

The benefits of optimal discharge air temperature systems become quite apparent with a look at the advantages offered with reduced supply air cfm airflow:

- Reduced first cost and installation cost by allowing smaller duct sizes and a smaller air distribution system
- Reduced bhp requirements. Depending on changes in duct size and the resulting total static pressure, a 20% reduction in supply air cfm can reduce fan bhp requirements by 25% or more
- Reduced fan sound power generation and a quieter room environment
- Reduced equipment room size may be possible due to using a physically smaller unit size
- Filtration flexibility

## Controllers

MicroTech III DDC control systems provide constant volume, variable air volume, 100% outside air, and/or dehumidification control flexibility. See “MicroTech III Unit Controls” on page 15 for more information.

### Summary of Available Options

- Multiple different compressor/coil capacity selections
- Multiple control options: VAV, CV, 100% OA, dehumidification
- Non-fused main power disconnect switch
- Dual nonfused main disconnect switches
- Non-averaging freeze/STAT for hot water or waterside economizer coil protection
- Unit phase failure/under voltage protection
- Premium efficiency fan motors
- TEFC fan motors
- Condenser water flow switch
- 4-row waterside economizer system
- Air cycle economizer system
- Modulating hot water heat control
- Staged electric heat
- Multi-direction, acoustic discharge plenum
- Factory-mounted and factory-controlled variable frequency drives
- High efficiency filtration options
- Right-hand and left-hand piping selections
- Multiple fan discharge arrangements
- Head pressure control valve
- Special coil coatings
- Double wall cabinet construction
- Seismic fan isolation

Independent refrigerant circuit units offer the following options:

- Five-row or six-row DX coils with enhanced heat transfer surfaces
- R-410A refrigerant
- Service and shut off valves on liquid and discharge

**Figure 15: MicroTech III DDC Controller**



## R-410A Refrigerant

Daikin SWP units with independent refrigerant circuits are available with non-ozone depleting R-410A refrigerant.

- R-410A refrigerant is environmentally friendly with zero ozone depleting allowance (ODP). Customers have no phase out and replacement concerns
- Units are factory engineered for proper cooling performance using R-410A
- R-410A efficiency is excellent. Daikin R-410A SWP units are available with EERs that exceed ASHRAE 90.1- 2010
- Units are factory charged with R-410A and synthetic oil (such as POE), and they include components and controls specifically tailored to R-410A
- Units are factory tested prior to shipment

Daikin SWP systems continue to provide industry leading performance, equipped with a complete MicroTech III control system. In addition to providing stable, efficient temperature, and static pressure control, the controller is capable of providing comprehensive diagnostics, alarm monitoring, and alarm specific component shutdown if critical equipment conditions occur. The unit controllers are factory mounted and configured for stand-alone operation or integration with a building automation system (BAS) through an optional communication module with our *Open Choices* feature.

### **The Benefits of Open Choices™ Software for Easy Integration**

Easy, low cost integration into most building automation systems without costly gateway panels.

- Flexibility to select either BACnet or LONWORKS communication. Units are LONMARK 3.4 certified with the appropriate communications module for LONWORKS networks
- Comprehensive unit control and status information is available at the BAS regardless of communication protocol
- Long-term choices for equipment adds or replacements, and for service support
- Flexible alarm notification and prioritization with Intrinsic Alarm Management (BACnet)
- Simplified BAS integration with the ability to set network parameters at the unit controller, reducing installation time and costs
- Easy monitoring and troubleshooting of communication status from the unit controller to the BAS

**Figure 16: MicroTech III Keypad Display**



## **Components**

Each SWP self-contained system is equipped with a complete MicroTech III unit control system that is pre-engineered, preprogrammed, and factory tested prior to shipment. Each of the MicroTech III unit control systems is composed of several components that are individually replaceable for ease of service. These components include:

- Unit controller with user interface display and navigation wheel
- Optional expansion modules
- Communication module (optional)
- Pressure transducers
- Unit-mounted temperature sensors
- Zone temperature sensor packages
- Humidity sensor

### **Main Control Board (MCB)**

The main control board (MCB) contains a microprocessor that is preprogrammed with the software necessary to control the unit. This provides that schedules, set points and parameters are not lost, even during a long-term power outage. The microprocessor board processes system input data and then determines and controls output responses. An RS-232 communication port is provided as standard to allow for direct or modem access with a PC-based service tool.

### **Expansion Modules**

These boards are used to expand the input and output capability of the unit controller. Each board communicates via serial data communications. These microprocessor based boards provide independent operation and alarm response even if communication is lost with the unit controller.

### **Communication Module**

An optional communication module provides the means to factory or field configure MicroTech III unit controls for interoperability with an independent BAS. Communication modules are available to support industry recognized communication protocols including BACnet MS/TP, BACnet/ IP and LONWORKS.

### **Keypad/Display**

All MicroTech III unit controllers include a push/pull navigation wheel and display. The display is a supertwist nematic type with highly visible black characters on a yellow background. The 5-line by 22-character format allows for easy to understand plain English display messages. All operating conditions, system alarms, control parameters and schedules can be monitored from the keypad/display. If the correct password has been entered, any adjustable parameter or schedule can be modified from the keypad.

### **Temperature and Humidity Sensors**

With the exception of the zone, outside air and return air sensors, all temperature sensors are factory installed and tested. Zone sensor packages are available to suit any application. A humidity sensor is available for field installation.

### **Static Pressure Transducers**

All pressure transducers are factory installed and tested. Connection and routing of field-supplied sampling tubes is done at time of unit installation.

### **Zone Temperature Sensors**

Two optional zone temperature sensors are available:

- Zone sensor with tenant override switch
- Zone sensor with tenant override switch and remote set point adjustment

### **Timed tenant override is a standard MicroTech III control feature.**

Zone sensors are required for the controller's purge cycle, space reset of supply air set point, and night setback or setup features. All zone sensors are field installed with field wiring terminated at a separate, clearly marked terminal strip.

### **Stand-alone Controller Features**

MicroTech III applied rooftop unit controls include all of the essential features required to make them capable of completely independent, stand-alone operation.

### **Internal Time Clock**

An internal, battery-backed time clock is included in the MicroTech III unit controller. Current date and time can be quickly and easily set at the user interface keypad.

### **Internal Schedule**

Seven daily schedules and one holiday schedule can be entered at the keypad of all unit controllers. For each of these eight schedules, one start and one stop time can be entered. Up to 10 holiday periods, of any duration, can be designated. The unit will automatically run according to the holiday schedule on the holiday dates. To handle special occasions, an additional 'one event' schedule can also be used.

In lieu of its internal schedule, the unit can be operated according to a network schedule from a BAS.

### **External Time Clock or Tenant Override Input**

An input is supplied that can be used to accept a field wired start/stop signal from a remote source. An external time clock, a tenant override switch, or both may be connected. Whenever the external circuit is closed, the controller overrides the internal schedule (if activated) and places the unit into the occupied mode.

If the internal schedule or a BAS network schedule is used, field wiring is not required.

### **Timed Tenant Override**

Off-hour operation flexibility is a must in today's office environments and even stand-alone MicroTech III controls handle it with ease. When unit operation is desired during unoccupied hours, initiate timed tenant override by pressing the tenant override button on either of the optional zone sensor packages. The unit then starts and runs in the occupied mode for a keypad-adjustable length of time (up to five hours). If the button is pressed again while the unit is operating, the timer resets to the full time allowance without interrupting unit operation. Tenant override operation also can be initiated by a BAS.

### **Three Remote Set Point Adjustment Options**

1. Remote user interface option (RUI).
2. Building automation system (BAS). See "The Benefits of Open Choices™ Software for Easy Integration" on page 15.
3. All constant air volume-zone temperature control (CAVZTC) unit controllers include an input that can be used to remotely adjust the zone cooling and heating set points. To use this feature, wire the optional zone sensor package with set point adjustment to the controller. The remote set point adjustment feature can be enabled or disabled from the keypad at any time. When enabled, remote set point adjustment is available even if the return temperature is selected to be the Control Temperature.

### **Auto/Manual Operation Selection**

Automatic or manual operation can be controlled either remotely or at the keypad.

All controllers include three inputs that can be used to enable or disable cooling, heating, and fan operation from remote switches. With the "heat enable" and "cool enable" terminals, the operator can enable cooling, heating, or both as desired. Using the system "OFF" terminals, the operator can disable the fans, and thus the entire unit.

From the keypad, there are a variety of occupancy and auto and manual control mode selections available to the operator:

- Occupancy modes
  - Auto
  - Occupied
  - Unoccupied
  - Bypass (tenant override)
- Control modes
  - Off manual
  - Auto
  - Heat/Cool
  - Cool only
  - Heat only
  - Fan only



### **Compressor Lead-lag Selection**

All unit controllers are capable of automatic compressor, lead-lag control.

### **Waterside Economizer Changeover**

On units equipped with a waterside economizer package, the MicroTech III unit controller includes an internal changeover strategy that compares entering cooling tower water temperature to the unit's mixed air temperature. If the entering water temperature is less than the mixed air temperature by a field-adjustable differential (typically 5°F to 7°F), the economizer control valve modulates in response to the cooling load.

### **Airside Economizer Changeover Selection**

On units equipped with an economizer, there are three methods of determining whether the outdoor air is suitable for free cooling: two methods sense enthalpy (dry bulb temperature and humidity) and one senses outdoor air dry bulb temperature.

The two enthalpy changeover methods use external, factory installed controls. One compares the outdoor ambient enthalpy to a set point; the other is a solid state device that compares the outdoor ambient enthalpy to the return air enthalpy. This comparative enthalpy control can improve total economizer performance.

All unit controls include an internal dry bulb changeover strategy that can be selected at the keypad. When this method is selected, the controller compares the outdoor air dry-bulb temperature to a keypad programmable set point. The external enthalpy control input is then ignored.

### **Cooling and Heating Lockout Control**

All unit controls include separate keypad programmable set points for locking out mechanical cooling and heating. Mechanical cooling is locked out when the outdoor temperature is below the cooling lockout set point; heating is locked out when the outdoor temperature is above the heating lockout set point. This feature can save energy cost by eliminating unnecessary heating and cooling during warm-up or cool-down periods or when the outdoor air temperature is mild.

### **Night Setback and Setup Control**

When one of the zone temperature sensors is connected to the unit controller, night setback heating and night setup cooling control are available. Separate, keypad programmable night heating and cooling set points are used to start the unit when necessary. After the unit starts, night setback and setup control is similar to normal occupied control except that the minimum outside air damper position is set to zero. If the outside air is suitable for free cooling, it is used during night setup operation.

Except for 100% outside air applications, night setback control is available even if the unit is not equipped with any heating equipment. When the space temperature falls to the night setback set point, the fans simply start and run until the temperature rises above the differential. This feature might be useful for applications that use, for example, duct-mounted reheat coils.

### **Morning Warm-up Control**

If the Control Temperature (space or return) is below set point when the unit enters the occupied mode, the morning warm-up control function will keep the outside air dampers closed while heat is supplied to satisfy set point. The outside air damper will remain closed until either the space temperature rises to the heating set point or the keypad adjustable morning warm-up timer expires (default is 90 minutes). The morning warm-up timer supplies the minimum required amount of outdoor air after a certain time regardless of the space temperature.

Morning warm-up control is automatically included on all except 100% outside air units. It is available even if the unit is not equipped with any heating equipment for applications that use duct mounted heating coils.

### **Condenser Head Pressure Control (Units without Waterside Economizer Only)**

Mechanical cooling is allowed whenever the entering cooling tower water temperature is 55°F or warmer, without the use of head pressure control. When the entering water temperature is below 55°F, a factory-installed and factory-controlled two-way modulating head pressure control valve can be utilized. The regulating valve is controlled by the MicroTech III controller to maintain refrigerant head pressure.

### **Outdoor Air Purge Control (Units with Airside Economizer Only)**

Purge control is designed to take advantage of cool early morning outside air conditions. It starts the fans and modulates the economizer dampers to maintain occupied cooling requirements during unoccupied periods, if conditions are appropriate. This provides the opportunity to flush the space with fresh outdoor air prior to occupancy. Purge operation is possible only during a keypad-adjustable time window prior to occupancy (0 to 240 minutes). When the purge-cycle is active, mechanical cooling is disabled. To use the purge feature, connect one of the zone temperature sensors to the unit controller. Below is a description of purge control operation.

During the purge time window, the unit starts and runs whenever these three requirements are met:

- The space temperature must be warm enough to enable occupied cooling
- The outside air enthalpy must be low enough to enable the economizer
- The outside air temperature must be at least 3°F less than the space temperature

When any one of these conditions is no longer true, the unit shuts down. As conditions allow, purge cycles the unit in this manner until it enters the occupied mode.

### **Proportional Integral (PI) Control**

The Proportional Integral (PI) control algorithm controls modulating actuators to maintain a measured variable (temperature or pressure) at or near its set point. For example, it controls economizer dampers to maintain the discharge cooling set point and it controls the supply fan variable frequency drives to maintain the duct static pressure set point. The integral control feature effectively eliminates “proportional droop” (load dependent offset) resulting in the tightest possible control.

For each PI loop, four keypad adjustable parameters allow the control loop to be properly tuned for any application:

- Period
- Dead band
- Proportional band
- Integral time

Appropriate default values for these parameters are loaded into each controller. These default values will provide proper control for most applications; therefore, field tuning is usually not required and thus start-up time is reduced.

### **Change Algorithm**

The PI function is also used to adjust set points instead of controlling variable speed drives or actuators directly. For example, in zone control applications, the PI loop automatically “changes” the discharge temperature set point (cooling or heating) as the Control Temperature deviates from the zone set point. Another PI loop then controls the economizer actuator or heating valve actuator using the current discharge temperature set point. Unlike a typical “mastersubmaster” reset strategy, this “cascade control” continuously adjusts the discharge set point, even if the Control Temperature’s deviation from set point remains constant. This means that the unit’s cooling or heating output is set according to the actual load, not just the current zone temperature. The tightest possible zone temperature control results because “proportional droop” (load dependent offset) is eliminated.

### **Calibrate**

When initiated at the keypad by an operator, the Calibrate function automatically calibrates all actuator position feedback inputs and all pressure transducer inputs. It does this by shutting the unit down and then driving all actuators to the full closed and full open positions. The controller records the input voltage values that correspond to these positions. The pressure transducer input voltages, which are assumed for 0.00-in. W.C., are also recorded. When Calibrate is finished, enter an operator command at the keypad to start the unit.

### **Field Output Signals**

All MicroTech III controls include two solid-state relay outputs that are available for field connection to any suitable device: the remote alarm output and the occupied output. These two outputs are used to signal field equipment of unit status.

**Remote Alarm Output:** The remote alarm output can be used to operate a 24 volt relay to provide a remote alarm signal to a light, audible alarm, or other device when an alarm condition exists at the unit.

**Fan Operation Output:** The fan operation output is used to operate a 24 volt relay to control field equipment that depends on fan operation; for instance, to open field installed isolation dampers or VAV boxes. To allow actuators enough time to stroke, the fan operation output is energized three minutes before the fans start. It then remains energized until thirty seconds after the unit airflow switch senses no airflow. The fan operation output is on whenever the unit airflow switch senses airflow.

**Outside Air Damper Output:** Use to signal an outside air damper actuator to open whenever the unit is in an occupied cooling or heating condition.

### Standard Control Options

SWP Self-Contained systems are available for most any constant or variable air volume application. MicroTech III controls offer three basic control configurations that use sophisticated state change control logic to provide stable, reliable and efficient control:

- Variable air volume with discharge temperature control (DAC)
- Constant air volume with zone temperature control (SCC)
- Constant air volume with discharge temperature control (DAC)

When combined with MicroTech III's many available control capabilities, both factory-installed and keypad-programmable, these three basic configurations can be customized to meet the requirements of the most demanding applications.

### Variable Air Volume with Discharge Temperature Control (DTC)

All VAV units provide true discharge temperature control in addition to duct static pressure control. Cooling only, cooling with single-stage "morning warm-up" heat, and cooling with modulating heat configurations are available.

### Constant Air Volume with Zone Temperature Control (SCC)

SCC units are available in either cooling only or cooling with modulating heat configurations. Either of these configurations is available for 100% recirculated, mixed, or 100% outdoor air applications.

### Constant Air Volume with Discharge Temperature Control (DTC)

DTC units are available in cooling only, cooling with single-stage "morning warm-up" heat, or cooling with modulating heat configurations. This unit configuration can be used for applications that have zone controlled terminal heating coils or for constant volume, 100% outdoor air applications. The discharge temperature control strategies used with the hybrid DTC unit are identical to those used with the DTC unit.

### Discharge Temperature Control

MicroTech III VAV-DTC and CAV-DTC controls provide sophisticated and flexible discharge air temperature control that is only possible with DDC systems. Separate discharge air temperature set points are used for cooling and modulating heating control. At the keypad, the operator can either enter the desired set points or select separate reset methods and parameters for each set point.

### Control Temperature

The Control Temperature makes the heat/cool changeover decision. It determines whether cooling or heating is enabled; the discharge temperature then determines whether cooling or heating is actually supplied. At the keypad, the operator can choose the source of the Control Temperature from among the following selections.

- Space temperature sensor
- Return temperature sensor
- Outside air temperature sensor (modulating heat only)
- Network communication

The operator enters separate cool and heat enable set points and deadbands that the Control Temperature is compared with (see Figure 17). When the Control Temperature is greater than or equal to the cooling set point plus DB/2, cooling is enabled. When the Control Temperature is less than or equal to the heat set point minus DB/2, heating is enabled. If desired, these set points and differentials can be set so that there is a dead band in which both cooling and heating are disabled. The controller's software prevents simultaneous cooling and heating.

Figure 17: Control Temperature Logic

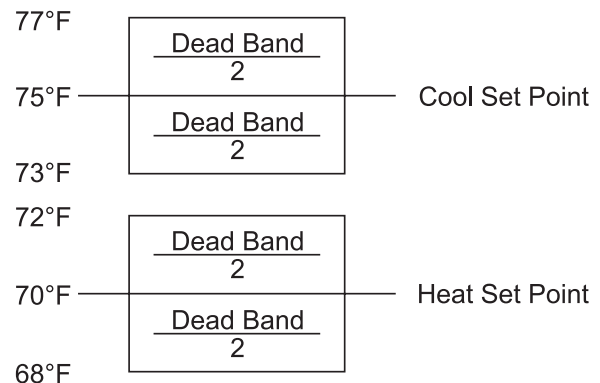

### Proportional Integral Modulation

When operating in economizer free cooling or unit heating, the previously described PI algorithm maintains discharge temperature control. It provides precise control of the economizer dampers, modulating gas heat, steam or hot water valves.

## Compressor Staging

Two staging algorithms are available to control a unit's multiple steps of capacity control, Degree-Time (also known as "average") and Nearest. These control algorithms provide reliable discharge temperature control while managing compressor cycling rates. Constraints on compressor staging are essential for preventing short cycling, which can reduce compressor life by causing improper oil return and excessive heat buildup in the motor windings.

The Degree-Time Compressor staging algorithm keeps track of the discharge temperature and stages cooling up or down to maintain an average temperature that is equal to the discharge cooling set point. A stage change can occur only (1) after the keypad adjustable inter-stage timer has expired (five minute default setting) and (2) if the discharge temperature is outside a keypad programmed dead band. After these two conditions have been met, staging occurs as the controller attempts to equalize two running totals: degree-time above set point and degree-time below set point. The result is that the average discharge temperature is maintained at the cooling set point.

The Nearest Compressor staging algorithm keeps track of the discharge temperature and stages cooling up or down to maintain the discharge temperature as close as possible to set point. A stage change can occur only (1) after the keypad adjustable inter-stage timer has expired (five minute default setting) and (2) if the control logic calculates that a stage change will result in a discharge temperature closer to set point than the existing condition. The controller logic continually calculates the expected effect of a stage change and uses this information before making a change. A change is made only if it will bring the discharge temperature closer to set point, resulting in a more consistent discharge temperature, reduced compressor cycling and more stable control VAV box control.

## Supply Air Reset

By automatically varying the discharge air temperature to suit a building's cooling or heating needs, supply air temperature reset can increase the energy efficiency of VAV and CAV-DTC systems. MicroTech III controllers offer a variety of different reset strategies that can be selected at the keypad. Because they are keypad programmable, reset strategies can be changed or eliminated as desired. Separate strategies can be selected for both cooling and modulating heat. If reset is not desired, a fixed discharge cooling or heating set point can be entered.

The following reset methods are available:

- Space temperature
- Return temperature
- Outdoor air temperature
- Supply airflow (VAV, cooling set point only)
- External 0–10 VDC or 0–20 mA signal
- Network communication

For all temperature reset methods, the minimum and maximum cooling and heating set points are keypad programmable along with the corresponding minimum and maximum space, return or outdoor air temperature parameters. For the supply airflow method, the discharge set point will be reset as the supply fan modulates between 30% adjustable and 100% adjustable. For the external method, the discharge set point will be reset as the voltage or current signal varies over its entire range. For units in a BAS network, the discharge set points are reset via the communication signal.

## Zone Temperature Control

MicroTech III CAV-ZTC controls provide the sophisticated and flexible zone temperature control that is only possible with DDC systems. Zone temperature sensors are available with or without a remote set point adjustment. With the remote adjustment model, the space set point can be set at the keypad or at the zone sensor package. Even if a zone sensor is connected, remote set point adjustment can be enabled or disabled as desired at the keypad.

## Control Temperature

The Control Temperature is the representative zone temperature. When compared with the zone set points, the Control Temperature determines whether the unit supplies heating, cooling, or neither. It also determines the amount of cooling or heating required to satisfy the load. Its source can be selected at the keypad from among the following selections:

- Zone temperature sensor
- Return temperature sensor

Because it is the representative zone temperature, the Control Temperature is the primary input to the MicroTech III zone temperature control algorithms. Control Temperature parameters are described below. The controller's software will prevent cooling and heating from being inadvertently enabled at the same time.



**Change and Proportional Integral Modulation**

When economizer “free” cooling or unit heating is required, the two MicroTech III PI loops combine for cascade-type control, providing the tightest possible zone temperature control. By controlling the discharge temperature along with the zone temperature, these functions eliminate temperature variations near the diffusers that could otherwise occur as a result of traditional zone control’s inherent lag effect.

**Change:** If the Control Temperature is above or below the set point by more than the dead band, the Change PI loop periodically adjusts the cooling or heating discharge air temperature set point either up or down as necessary. The amount of this set point change corresponds to the Control Temperature’s position in the modulation range. The farther the Control Temperature is from the set point, the greater the discharge set point change will be. The Change-adjusted discharge cooling and heating set points are limited to ranges defined by keypad programmable maximum and minimum values.

**PI:** Using the Change function’s current discharge set point, the PI function maintains precise discharge temperature control by modulating the economizer dampers and gas heat, steam or hot water heating valves.

**Compressor Staging**

Compressor staging is controlled directly by the Control Temperature. When the Control Temperature is warmer than the zone cooling set point, cooling is staged up; when the Control Temperature is cooler than the zone cooling set point, cooling is staged down. However, a stage change can only occur when the Control Temperature is outside the dead band (see Figure 18). Staging is constrained by an inter-stage delay timer (five minute default setting) and minimum and maximum discharge air temperature limits (all keypad programmable). These constraints protect the compressors from short cycling while eliminating temperature variations near the diffusers.

**Figure 18: Compressorized Logic**

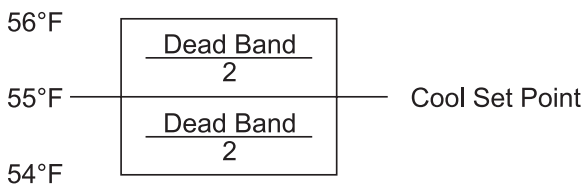

**Project Ahead Algorithm**

Because the inherent lag effect in zone temperature control applications can cause overshoot during warm-up or cool-down periods, MicroTech III features a “Project Ahead” control algorithm. Project Ahead calculates the rate at which the Control Temperature is changing and reduces the unit’s cooling or heating output as the zone temperature nears its set point, essentially eliminating overshoot.

**Duct Static Pressure Control**

On all VAV-DTC units, duct static pressure control is maintained by the PI algorithm, which provides precise control of the supply fan variable speed drive. The keypad programmable set point can be set between 0.20-in. W.C. and 4.00-in. W.C.

On larger buildings with multiple floors, multiple trunk runs or large shifts in load due to solar effects (east/west building orientation), an optional second duct static sensor is offered. The MicroTech III controller automatically selects and uses the lower of the two sensed pressures to control fan volume to provide adequate static pressure to the most demanding space at all times.

**Operating States**

Operating states define the current overall status of the self-contained system. At the user interface, the operator can display the current operating state and thereby quickly assess the unit’s operating condition.

## Alarm Management and Control

MicroTech III unit controllers are capable of sophisticated alarm management and controlled response functions. Each alarm is prioritized, indicated, and responded to with the appropriate action. The active alarm (up to 10 alarms, arranged by alarm priority) and previous alarm (up to 25 alarms, arranged by date/time cleared), each with a time and date stamp, can be displayed at the user interface. Generally speaking, whenever a current alarm is cleared, it is logged as a previous alarm and the oldest previous alarm is removed.

### Alarm Priority

The various alarms that can occur are prioritized according to the severity of the problem. See [Table 1](#). Three alarm categories are used: faults, problems, and warnings.

1. Faults are the highest priority alarms. If a fault condition occurs, the complete unit shuts down until the alarm condition is gone and the fault is manually cleared at the keypad. A fault example is Fan Fail alarm.
2. Problems are the next lower priority to alarms. If a problem occurs, the complete unit does not shut down, but its operation is modified to compensate for the alarm condition. A problem automatically clears when the alarm condition that caused it is gone. Compressor Fail is an example of a problem where only the affected compressor is shut down.
3. Warnings are the lowest priority alarms. No control action is taken when a warning occurs; it is indicated to alert the operator that the alarm condition needs attention. To make sure that they are read, the operator must manually clear all warnings. Dirty Filter indication is an example of a warning.

Generally, a specific alarm condition generates an alarm that falls into only one of these categories. Under different sets of circumstances, however, the freezestat and most of the sensor failure alarm conditions can generate alarms that fall into multiple categories.

### Adjustable Alarm Limits

Four alarm indications have adjustable limits that are used to trigger the alarm. The high return temperature alarm and the high and low supply temperature alarms are adjusted at the user interface. The dirty filter alarm(s) is adjusted at the sensing device.

**Table 1: MicroTech III Alarm Summary**

Alarm Name	Fault	Problem	Warning
Freeze	X	X	
Smoke	X		
Temperature Sensor Failure	X	X	
Duct High Limit	X		
High Return Temperature	X		
High Discharge Temperature	X		
Low Discharge Temperature	X		
Fan Failure	X		
Fan Retry		X	
Discharge Air Capacity Feedback	X		
Economizer Stuck	X	X	
Auxillary Control Board Enabled		X	
Low Airflow		X	
Circuit 1–8 High Pressure		X	
Circuit 1–8 Low Pressure/Frost		X	
Compressor 1–8 Motor Protection		X	
Compressor 1–8 Failure		X	
Airflow Switch (False Airflow)			X
Dirty Filter			X

**General**

This section contains basic application and installation guidelines to consider as part of the detailed analysis of any project.

Units are intended for use in normal heating, ventilating, and air conditioning applications. Consult your local McQuay sales representative for:

- Applications involving operation at high entering condenser water temperatures; high altitudes; or noncataloged voltages
- Applications requiring modified or special control sequences
- Job-specific unit selections that fall outside of the range of the catalog tables, such as 100% outside air applications

For proper operation, rig units following instructions in [IM 1032](#). If fire dampers are required, install them in the ductwork according to local codes. Space is not provided for these dampers in the unit.

Explicitly follow factory check, test, and start procedures for satisfactory start-up and operation (see [IM 1032](#)).

Many self-contained system applications take advantage of the significant energy savings provided by the use of economizer operation. When a water economizer system is used, mechanical refrigeration typically is not required below an entering condenser water temperature of 55°F. Standard Daikin self-contained systems are designed to operate with entering water temperatures down to 50°F when a water economizer is used and 55°F with no water economizer. For applications where a water economizer system cannot be used, a modulating head pressure control system is available to permit operation at entering condenser water temperatures below 55°F.

**Unit Location**

The floor must be structurally strong enough to support the unit with minimum deflection (see “Unit Weights” on page 36). Provide proper structural support to minimize sound and vibration transmission. Consider a concrete floor. Extra design consideration is required when installing on a wooden structure. Install units level from front-to-back and over their length.

Locate unit fresh air intakes away from building flue stacks, exhaust ventilators, and areas containing automotive or other exhaust to prevent the possible introduction of contaminated air to the system. Consult code requirements for minimum fresh air volumes.

Allow sufficient space around the unit for service and maintenance clearance. Refer to [Figure 19](#) for recommended service/maintenance clearances and “Recommended Clearances” on page 64. Locate equipment room access doors in a manner that can assist in service access if needed (e.g., coil removal). Contact your local Daikin sales representative if reduced service/maintenance clearances are required.

Where code considerations such as the NEC require extended clearances, they take precedence over minimum service/maintenance clearances.

**Figure 19: Recommended Service and Maintenance Clearances**

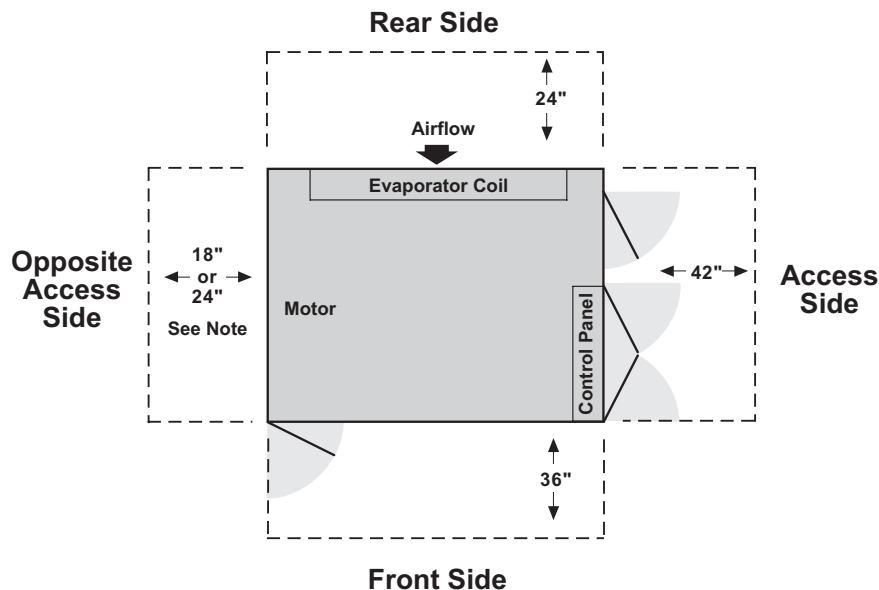

**NOTE:** If water and condenser drains are on the motor side, 24" is required.

## Acoustical Considerations

Good acoustical design is a critical part of any successful installation and should start at the earliest stages in the design process. Each of the four common sound paths must be addressed. They are:

- Radiated sound through the casing of the unit
- Structure-borne vibration
- Airborne sound through the supply air duct
- Airborne sound through the return air duct

Basic guidelines for good acoustical performance include:

1. Always provide proper structural support under the unit.
2. Provide adequate mass in the floor structure, especially when located over an occupied space where good acoustics are essential.
3. Seal all supply and return air duct penetrations once the duct is installed.
4. Don't overlook the return air path. Always include some duct work (acoustically-lined drop down elbow) at the return inlet.
5. Minimize system static pressure losses to reduce fan sound generation.
6. Select the appropriate unit/fan for the application. Select fans as close as possible to their peak static efficiency. To assist you, peak static efficiency is identified by the first system curve to the right of the shaded "Do not select" region on each fan curve. See [page 57](#) through [page 63](#).
7. Design duct systems to minimize turbulence.
8. Account for low frequency duct breakout noise in system design. Route the first 20' of rectangular duct over nonsensitive areas and avoid large duct aspect ratios. Consider round or oval duct to reduce breakout.

### Equipment Room

Locate the equipment room away from sound sensitive areas. Whenever possible, isolate the equipment room from these areas by locating restrooms, utility rooms, stairwells, hallways, elevators, etc. around its perimeter. This allows not only isolation from radiated sound but provides the capability to route ductwork over less sensitive areas.

Acoustically seal the equipment room with a high quality, flexible material to prevent air and noise from escaping. Even a small leak compromises the acoustic performance of the installation. Design the equipment room door to seal tightly on a perimeter gasket.

Equipment room wall construction should be concrete block or offset, double stud. The decision depends on the critical nature of the application. If offset, use double stud construction. Line the cavity with glass fiber insulation and use a double layer of wallboard on each side of the wall.

### Ductwork

Fan noise travels through the ductwork to occupied spaces; it likely is the most challenging to control. Careful duct design and routing practice is required. The ASHRAE Applications Handbook discusses sound attenuation relevant to self-contained system applications. Advances in acoustical science allow for designing sound levels in a given space if equipment sound power data is available. Contact your local McQuay sales representative for sound power data for your specific application.

### Return Duct

The return duct is often overlooked. Duct return air directly to the unit or into the equipment room. If ducted to the equipment room, install an elbow within the equipment room. Running a return air drop near the floor of the room provides added attenuation. Extend a length of lined ductwork from the equipment room to a length of 15 feet. The maximum recommended return air duct velocity is 1000 feet per minute.

### Supply Duct

Extend a lined section of supply air duct at least 15 feet from the equipment room. Using round duct significantly reduces low frequency sound near the equipment room. If rectangular duct is used, keep the aspect ratio of the duct as small as possible. The large flat surfaces associated with large aspect ratios transmit sound to the space and increase the potential for duct generated noise such as oil canning. The maximum recommended supply air duct velocity is 2000 feet per minute.

Factory-designed and factory-built acoustic discharge plenums are available with multiple outlets to minimize difficult transitions, tight radius duct connections, and the sound compromises they can cause. Multiple factory-fabricated outlet opening sizes are available as well as multiple openings in a single plenum.

### Duct Protection

An adjustable duct high limit switch is standard equipment on all SWP systems with VAV controls. This is of particular importance when using fast-acting, normally closed boxes. The switch is field adjustable; set it to meet the specific rating of the system ductwork.

### Vibration Isolation

Make duct connections to the unit or to the acoustic discharge plenum with a flexible connection. Though flexible piping and electrical connections are not required, pay attention to these areas to avoid vibration transmission from outside sources to the SWP unit.



## Condenser Water Piping

Always follow good industry practice in the water piping system design. Attention to water treatment and proper strainer application are always necessary. All SWP systems feature mechanically cleanable condensers and optional waterside economizer coils. To allow periodic cleaning of the condensers and economizer coils, provide isolation valves. Condensers, economizer coils and hot water coils are provided with vent and drain connections.

Always review for possible requirements for condenser piping insulation, especially if cold entering condenser water conditions (<55°F) will be experienced.

**Figure 20: Condensers**



## Head Pressure Control

If cold entering condenser water conditions (<55°F) will be experienced, use a waterside economizer or a condenser head pressure control valve. A two-way, head pressure activated control valve is available factory installed for these applications. The head pressure control allows entering condenser water temperatures as low as 40°F. A head pressure control valve is not required when the SWP unit is applied with a factory waterside economizer package.

**Figure 21: Head Pressure Control Valves**

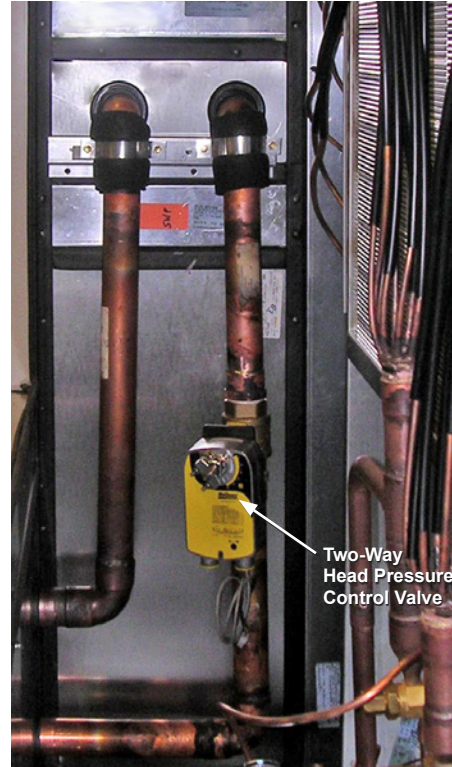

## Variable Air Volume

Daikin SWP units offer variable frequency drives for fan speed control. VFDs offer reliable operation over a wide range of airflow, with variable frequency drives offering advantages in sound and energy performance. In addition, Daikin offers the ability to sense duct static pressure in multiple locations, enhancing control accuracy and helping minimize energy use.

## Variable Frequency Drives

Variable frequency drives provide the most efficient means of variable volume control by taking advantage of the fan law relation between fan speed (rpm) and fan brake horsepower (bhp). Also, since airflow reduction is accomplished by changing fan speed, the noise penalties often associated with mechanical control devices, e.g., inlet vanes, are not introduced. The following equation illustrates how fan bhp varies as the cube of the change in fan speed:

$$hp_2 = hp_1 \left( \frac{\text{density}_2}{\text{density}_1} \right) \left( \frac{\text{rpm}_2}{\text{rpm}_1} \right)^3$$

In an ideal system, at 50% fan speed, brake horsepower is reduced to 12.5% of that at full speed.

Variable frequency control varies the speed of the fan by adjusting the frequency and voltage to the motor. Keeping a constant volts/frequency ratio (constant magnetic flux) to the motor allows the motor to run at its peak efficiency over a wide range of speeds and resulting fan airflow volumes.

**Figure 22: Variable Frequency Drives**



## Duct Static Pressure Sensor Placement

Static pressure should be sensed near the end of the main duct trunk(s). Adjust the MicroTech III static pressure control so that at full airflow all of the terminals receive the minimum static pressure required plus any downstream resistance. Control is to the lowest static pressure set point that satisfies airflow requirements. Lower static pressure set points reduce fan brake horsepower requirements and fan sound generation.

Locate the static pressure sensor tap in the ductwork in an area free from turbulence effects and at least 10 duct diameters downstream and several duct diameters upstream from any major interference, including branch takeoffs. The SWP MicroTech III control system can receive a second duct static pressure sensor in installations having multiple duct trunks or significantly varying zones. The control logic maintains static pressure at both sensors.

## Zone Sensor Placement

Placement of the zone temperature sensor is extremely important to provide proper and economical operation of the heating and cooling system. Generally, Daikin recommends locating the space sensor on an inside wall (3 to 5 feet from an outside wall) in a space having a floor area of at least 400 square feet. Do not locate the sensor below the outlet of a supply air diffuser, in the direct rays of the sun, on a wall adjacent to an unheated or abnormally warm room (boiler or incinerator room), or near any heat producing equipment. Where zone sensor placement is a problem, all SWP zone control systems have, as standard, the capability to use the return air sensor for heating and cooling control.

## Filtration

Routinely replace filters to minimize filter loading. As filters get dirty, the filter pressure drop increases, affecting system airflow and energy requirements. The effect of filter loading is the most critical when using high efficiency filters.

When making a fan selection, include a pressure drop component in the system total static pressure to account for dirty filters. Use a value midway between clean and dirty filter ratings. If a minimum airflow is critical, make the fan selection using the higher, dirty filter pressure drop value. For VAV systems, consider setting the fan control device so part of its modulation range can be used to maintain airflow as filters become dirty. Following these recommendations should limit airflow fluctuation as the filters load.

## System Operating Limits

SWP units can be applied in a wide range of system needs. High cfm/ton or high/low discharge temperature applications are available. However, for proper system operation, some application limits do apply.

### Airflow

Maximum cfm limits based on coil face velocity are listed in the Physical Data tables starting on [page 31](#). Separate minimum design cfm limits by unit size are listed in the physical data table for constant and variable air volume applications. Limit fan modulation to 40% of the minimum design cfm limit. Minimum airflow conditions are dependent on fan selection criteria also. Contact your Daikin sales representative to answer questions on minimum airflow capability or for conditions not shown in this catalog.

VAV box minimum airflow settings should correspond with the minimum VAV fan operating point. All units are provided with multigroove, fixed pitch sheaves. During system air balance, alternate fixed pitch sheaves may be needed to match final system requirements. Alternate sheaves are available from Daikin.

### Fan Heat

Sensible heat gain from the fan, fan motor, and drives occurs in all fan systems; consider its effect during equipment selection. It is an added load in cooling and an added source when in heating. The majority of the heat gain occurs through the fan itself, as the air elevates from the low-pressure side to the high-pressure side of the fan. Moving the motor out of the air stream has a negligible effect on overall fan heat gain. A unit with higher fan power requirements/higher fan heat has less net cooling capability and may not have enough left to satisfy system loads.

As a rule, typical supply fan heat gain is 3°F. However, fan heat gain can be calculated quickly once the fan is selected and the fan brake horsepower is determined. Using [Figure 23](#), select your fan brake horsepower on the horizontal axis and move up vertically until you intersect with the heat gain curve. Then move horizontally to find the fan heat gain in MBh.

**Figure 23: Fan and Motor Heat Gain**

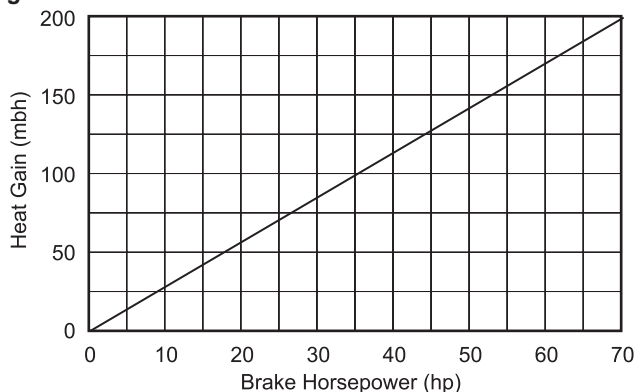

$$\text{Fan temperature rise} = \frac{(\text{fan heat (MBh)})}{(1.085 \times \text{fan cfm})}$$

A draw-through unit has the fan located after the DX cooling coil. In this arrangement, fan heat is applied as reheat to the cold, conditioned air coming off of the coil. This arrangement has a lower sensible heat ratio and higher dehumidification capability than a blow-through coil arrangement. The discharge temperature available to the supply duct is always the sum of the coil leaving air temperature plus the fan temperature rise. Consider this when selecting the supply air volume required to satisfy space requirements.

**Example:**

$$52^{\circ}\text{F}_{\text{leaving coil temperature}} + 3^{\circ}\text{F}_{\text{fan temperature rise}} = 55^{\circ}\text{F}_{\text{discharge air temperature}}$$

### Condenser Water Flow

System capacity tables provide selections for a condenser flow rate of 3 gpm/ton. For a given entering condenser water temperature, 3 gpm/ton provides maximum unit performance. Reducing condenser water flow rates to 2.5 or 2 gpm/ton can significantly reduce pumping energy costs and reduce piping costs. Compare and evaluate the reduction in pumping energy to the change in unit performance. Use the SWP capacity tables ([Table 11 on page 39](#)) for condenser flow rates from 2 to 3 gpm/ton, using the appropriate leaving condenser water temperature column (interpolation is allowed). The minimum condenser flow rate is 2 gpm/ton.

### Coil Freeze Protection Air Density Correction

Always consider coil freeze protection when applying units in geographic areas that experience subfreezing temperatures. Careful design of outside air/return air mixing systems is critical to minimizing freeze potential. Some applications may require using glycol and/or preheat coils. No control sequence can prevent coil freezing in the event of power failure.

A non-averaging freezestat control is a factory installed available option with hot water heat or a waterside economizer. If a potential freeze condition is sensed, unit water valves are driven to the full open position, the supply fan deenergizes, and an alarm is indicated.

In nonducted return applications, where the equipment room is the mixing plenum, consider some form of heat within the equipment room.

## Air Density Correction

Fan performance data is based on standard 70°F air temperature and zero feet altitude (sea level). For applications other than standard, multiply the density ratio to actual static pressure values. Density correction factors are expressed as a function of temperature and altitude in [Table 2](#).

**Table 2: Temperature and Altitude Conversion Factors**

Air Temperature	Altitude (ft)								
	0	1000	2000	3000	4000	5000	6000	7000	8000
-20°F	1.20	1.16	1.12	1.08	1.04	1.00	0.97	0.93	0.89
0°F	1.15	1.10	1.08	1.02	0.99	0.95	0.92	0.88	0.85
20°F	1.11	1.06	1.02	0.98	0.95	0.92	0.88	0.85	0.82
40°F	1.06	1.02	0.98	0.94	0.91	0.88	0.84	0.81	0.78
60°F	1.02	0.98	0.94	0.91	0.88	0.85	0.81	0.79	0.76
70°F	1.00	0.96	0.93	0.89	0.86	0.83	0.80	0.77	0.74
80°F	0.98	0.94	0.91	0.88	0.84	0.81	0.78	0.75	0.72
100°F	0.94	0.91	0.88	0.84	0.81	0.78	0.75	0.72	0.70
120°F	0.92	0.88	0.85	0.81	0.78	0.76	0.72	0.70	0.67
140°F	0.89	0.85	0.82	0.79	0.76	0.73	0.70	0.78	0.65

## Unit Wiring

All units require 3-phase, 60 Hz, 208, 230, 460, or 575 volt power or 3-phase, 50 Hz, 400-volt power. Units will operate satisfactorily at  $\pm 10\%$  of rated voltage at the power connection terminals of the unit. All units include individual branch circuit fusing of all motor loads and have a single-point power connection. A factory-mounted, nonfused disconnect switch is an available option. Install all wiring in accordance with the NEC and local codes.

## Terms of Sale

All products are offered pursuant to Daikin's standard terms and conditions of sale including limited product warranty, which can be accessed at [www.DaikinApplied.com](http://www.DaikinApplied.com).



Achieving the optimal performance of any system requires both accurate system design and proper equipment selection. Factors that control unit selection include applicable codes, ventilation and filtration requirements, heating and cooling loads, acceptable temperature differentials, and installation limitations. Daikin SWP units offer a wide selection of component options providing the capability to meet diverse application needs.

The Daikin SelectTools™ software selection program allows your local McQuay sales representative to provide you with a fast, accurate, and complete selection of Daikin SWP units. Unit selection also can be accomplished through reference to physical, performance, dimensional and unit weight data included in this catalog. Due to the variety of cooling system options available, only a sampling of cooling capacity data is presented here.

To properly select equipment, follow these steps:

1. Select the unit size and compressor combination
2. Select the heating system
3. Select the fan and motor

The following example illustrates the catalog selection procedure.

**Selection Example:**

*Scheduled design requirements:*

Supply air volume . . . . . 21,000 CFM  
 Maximum face velocity . . . . . 550 fpm is chosen\*  
 Supply fan external . . . . . SP 2.00" w.g.  
 Altitude . . . . . sea level

- Variable air volume system with fan speed control
- Hot water heat
- Water economizer system 4" 30% (MERV8) pleated filters
- 460 V / 60 Hz / 3 Ph
- Double wall construction
- R-410A refrigerant premium efficiency motor

\*600 fpm is the design limit per page with tables starting on page 31

*Summer Design:*

DX coil mixed air dry bulb . . . . . 80°F  
 DX coil mixed air wet bulb . . . . . 67°F  
 Sensible load . . . . . 575,000 Btu/hr  
 Total load . . . . . 750,000 Btu/hr  
 Supply fan sensible heat . . . . . 3°F rise  
 Entering condenser water . . . . . 85°F  
 Leaving condenser water . . . . . 95°F  
 Minimum condenser water . . . . . 55°F

*Winter Design:*

Return air temperature . . . . . 60°F  
 Space heating load . . . . . 1,000 MBh  
 Entering hot water temperature . . . . . 180°F

**Step 1: Unit Size Selection**

Unit size is based on coil face area and cooling capacity requirements. Use supply air capacity and maximum face velocity constraints as a guide for selecting coil dimensions and cabinet size.

Based on the given data, the appropriate coil face area is determined as follows:

$$\begin{aligned} \text{Minimum face area} &= \text{cfm}/\text{maximum face velocity} \\ &= 21,000 \text{ cfm}/550 \text{ fpm} \\ &= 38.2 \text{ square feet} \end{aligned}$$

**NOTE:** Unit data is based on standard air conditions of 70°F at sea level. See "Application Considerations" on page 23 for temperature/altitude conversion factors for nonstandard conditions.

Referring to the Physical Data tables starting on page 31, the 40.8 square foot coil of the SWP 062HSM satisfies the requirements.

**Step 2: Unit DX Cooling Selection**

Since the design cfm is less than the nominal value in the DX Cooling Capacity Data table, adjust the capacities per tables on starting on page 39.

$$\begin{aligned} \text{cfm correction factor} &= \text{design cfm}/\text{nominal cfm} \\ &= 21,000 / 21,500 = 97.7\% \end{aligned}$$

Total heat correction multiplier = 0.995

Sensible heat correction multiplier = 0.987

Using the Performance Data starting on page 39, the unit selection is a SWP 062 HS with (2) 13 hp and (2) 15 hp compressors. Unit performance from the table equals 806.0 TMBh / 587.0 SMBh at 190 gpm. Adjusting for the specified cfm yields:

$$\begin{aligned} \text{Total capacity} &= 806.0 \text{ MBh} \times 0.995 = 800.9 \text{ MBh} \\ \text{Sensible capacity} &= 587.0 \text{ MBh} \times 0.987 = 579.2 \text{ MBh} \\ \text{Coil LAT} &= 80^\circ\text{F} - 579.0 \text{ MBh} / \left( \frac{1.085 \times 21,000 \text{ cfm}}{1,000} \right) = 54.7^\circ\text{F} \\ \text{Condenser flow rate} &= 196 \text{ gpm} \times 0.995 = 195 \text{ gpm} \end{aligned}$$

**Step 3: Economizer Capacity Selection**

Determine waterside economizer capacity by referring to the appropriate table. See “Waterside Economizer Capacity” on page 44 for 40.8 sq.ft. coil. Use entering air of 80/67°F and entering water of 55°F at 185 gpm. Interpolating for the required gpm, economizer performance equals 497.8 TMBh / 473.0 SMBh at the unit’s nominal cfm. See Waterside Economizer Capacity Correction Factors tables starting on page 48, to find performance at the specified cfm.

$$\text{Total capacity} = 415.2 \text{ MBh} \times 1.12 = 465.0 \text{ MBh}$$

$$\text{Sensible capacity} = 363.8 \text{ MBh} \times 1.19 = 432.9 \text{ MBh}$$

**Step 4: Heating Selection**

Determine Hot Water Capacity from the tables starting on page 49. After interpolating for the specified cfm, page 49 indicates a capacity of 1,002.0 MBh.

**Step 5: Fan/Motor Selection**

Fan/motor selection is based on unit total static pressure and design airflow. Total static pressure includes the internal air pressure drops of unit components and external air pressure drops of supply and return air duct systems. See Component Pressure Drops starting on page 50 for internal pressure drops of unit components. Values in the table may be interpolated for the specified cfm.

Internal pressure drops:

DX coil (wet surface) . . . . .	0.80" w.g.
Economizer coil (dry surface). . . . .	0.49" w.g.
Hot water coil . . . . .	0.52" w.g.
4", 30% efficient filters . . . . .	0.29" w.g.
Total internal pressure drop . . . . .	2.1" w.g.

External pressure drop:

Supply + return duct . . . . . 2.00" w.g.

Total static pressure = internal drops + external drops

$$= 2.1" + 2.00"$$

$$= 4.10" \text{ w.g.}$$

Entering the fan curve for the SWP 062 HSM at 21,000 cfm and 4.10" w.g. yields 18.35 required fan brake horsepower. A 20 horsepower motor can be selected with a 33" diameter fan.

**Step 6: Calculating Unit Weight**

Referring to the tables starting on page 36. For an SWP 062 HS:

Unit Weight:	SWP basic unit . . . . .	6179
	+ 30% filters. . . . .	22
	+ 6-row evaporator coil . . . . .	668
	+ economizer coil. . . . .	557
	+ water (econ. coil) . . . . .	250
	+ hot water coil . . . . .	200
	+ water (HW coil). . . . .	49
	+ SAF motor . . . . .	235
	+ VFD . . . . .	35
	+ SAF assembly . . . . .	592
	<hr/>	
		8,752 lbs.

**Step 7: Supply Power Wiring**

Supply power wire sizing for a unit is based on the circuit with the highest amperage draw. All electrical equipment is wired to a central control panel for either single or optional dual power connections. Refer to Electrical Data on page 69 for FLA and RLA ratings. Determine Minimum Circuit Ampacity (MCA) as follows:

$$\text{MCA} = [1.25 \times \text{RLA or FLA of largest motor}] + [1.00 \times \text{RLA or FLA of all other loads}] + [2 \text{ amps (controls)}]$$

	<u>RLA/FLA</u>
(2) 13 horsepower compressors (amps each) . . . . .	18.3
(2) 15 horsepower compressors (amps each) . . . . .	18.5
25 horsepower premium efficiency supply fan motor. . . . .	24.5 amps

$$\text{MCA} = [1.25 \times 24.5 \text{ amps}] + [18.3 + 18.3 + 18.5 + 18.5] + [2] = 106.2 \text{ amps}$$

**NOTE:** If a unit is selected with non-concurrent electric heat, calculate the MCA for both the heating mode and the cooling mode and the larger value used.

**Table 3: SWP 012 through SWP 033 Physical Data**

Data	Small Cabinet					
	023		028		033	
<b>Compressor</b>						
Quantity	2					
Size (HP)	6, 15	6, 15	10, 15	10, 15	15 (2)	15 (2)
Number of refrigeration circuits	2					
<b>Evaporator coil</b>						
Coil size	Standard	Large	Standard	Large	Standard	Large
Face area (ft <sup>2</sup> )	17.2	25.2	17.2	25.2	17.2	25.2
Number of rows	5					
FPI	12					
<b>Performance</b>						
Total capacity <sup>1</sup> (MBH)	312	334	357	386	411	448
<b>Pre-heating coil</b>						
Hot water coil face area (ft <sup>2</sup> )	24.8 or 24.4					
Available rows	1 or 2					
<b>Waterside economizer coil</b>						
Face area (ft <sup>2</sup> )	17.2	25.2	17.2	25.2	17.2	25.2
Row	4					
FPI	12					
Maximum working pressure (PSIG)	300 standard, 450 optional					
<b>Face loaded filters</b>						
(Quantity) Size	(3) 12×24, (6) 24×24					
2" filter options	30% (MERV7), 75% (MERV13)					
4" filter options	30% (MERV8), 75% (MERV11), 85% (MERV14)					
Pre-filter options	2"-30% with 4"-65%, 2"-30% with 4"-75%, 2"-30% with 4"-85%					
<b>Evaporator fan<sup>2</sup></b>						
Quantity	1					
Available diameter (Inches)	12, 15, 18, 20, 22, 24					
Maximum motor size (HP)	20					
CAV minimum design (CFM) <sup>3</sup>	3440	5040	3440	5040	3440	5040
VAV minimum design (CFM) <sup>3</sup>	6880	10080	6880	10080	6880	10080
Maximum design (CFM) <sup>3</sup>	10320	15120	10320	15120	10320	15120
<b>Electric heat</b>						
Nominal output (kW)	34					
Control sequence	2-stage					
<b>Condenser</b>						
Maximum working pressure (PSIG)	300 standard, 450 optional					
Mechanical cooling minimum EWT (°F)	55					
Minimum flow rate (GPM)	52	56	59	64	69	75
Maximum flow rate (GPM)	78	84	89	96	103	112

**NOTE:**

1. Based on AHRI 340/360 standard rating conditions, 80/67°F to the coil, 85/95°F condenser water.
2. Standard fan TSP limit is 6.0 inches of water. Consult your local Daikin sales representative for applications beyond this range.
3. Minimum design airflow calculated for CAV at 200 fpm, VAV at 400 fpm and a maximum design airflow calculated at 600 fpm.

**Table 4: SWP 039 through SWP 050 Physical Data**

Data	Small Tall Cabinet				
	039		044		050
<b>Compressor</b>					
Quantity	3				
Size (HP)	10 (2), 15	10(2), 15	10, 15 (2)	10 (2), 15	15
Number of refrigeration circuits	3				
<b>Evaporator coil</b>					
Coil size	Standard	Large	Standard	Large	Large
Face area (ft <sup>2</sup> )	25.2	29.8	25.2	29.8	29.8
Number of rows	5				
FPI	12				
<b>Performance</b>					
Total capacity <sup>1</sup> (MBH)	516	535	589	645	645
<b>Pre-heating coil</b>					
Hot water coil face area (ft <sup>2</sup> )	30.3 or 29.8				
Available rows	1 or 2				
Minimum steam coil face area (ft <sup>2</sup> )	19.8				
Available rows	1 through 4				
FP	6 through 14				
<b>Waterside economizer coil</b>					
Face area (ft <sup>2</sup> )	25.2	29.8	25.2	29.8	29.8
Rows	4				
FPI	12				
Maximum working pressure (PSIG)	300 standard, 450 optional				
<b>Face loaded filters</b>					
(Quantity) Size	(9) 24×24				
2" filter options	30% (MERV7), 75% (MERV13)				
4" filter options	30% (MERV8), 75% (MERV11), 85% (MERV14)				
Pre-filter options	2"-30% with 4"-65%, 2"-30% with 4"-75%, 2"-30% with 4"-85%				
<b>Evaporator fan<sup>2</sup></b>					
Quantity	1				
Available diameter (Inches)	18, 20, 22, 24, 27				
Maximum motor size (HP)	20				
CAV minimum design (CFM) <sup>3</sup>	5040	5960	5040	5960	5960
VAV minimum design (CFM) <sup>3</sup>	10080	11920	10080	11920	11920
Maximum design (CFM) <sup>3</sup>	15120	17880	15120	17880	17880
<b>Electric heat</b>					
Nominal output (kW)	34				
Control sequence	2-stage				
<b>Condenser</b>					
Maximum working pressure (PSIG)	300 standard, 450 optional				
Mechanical cooling minimum EWT (°F)	55				
Minimum flow rate (GPM)	86	89	98	107	107
Maximum flow rate (GPM)	129	134	147	161	161

**NOTE:**

1. Based on AHRI 340/360 standard rating conditions, 80/67°F to the coil, 85/95°F condenser water.
2. Standard fan TSP limit is 6.0 inches of water. Consult your local Daikin sales representative for applications beyond this range.
3. Minimum design airflow calculated for CAV at 200 fpm, VAV at 400 fpm and a maximum design airflow calculated at 600 fpm.

**Table 5: SWP 044 through SWP 055 Physical Data**

Data	Medium Cabinet								
	044	050			056	062		065	
<b>Compressor</b>									
Quantity	3				4				
Size (HP)	10 (2), 15	15			13	13 (2), 15 (2)		15	
Number of refrigeration circuits	3				4				
<b>Evaporator coil</b>									
Coil size	Standard	Standard	Large	Standard	Large	Standard	Large	Standard	Large
Face area (ft <sup>2</sup> )	40.8	40.8	45.8	40.8	45.8	40.8	45.8	40.8	45.8
Number of rows	5								
FPI	12								
<b>Performance</b>									
Total capacity <sup>1</sup> (MBH)	624	690	705	774	792	816	834	865	884
<b>Pre-heating coil</b>									
Hot water coil face area (ft <sup>2</sup> )	45.5 or 45.0								
Available rows	1 or 2								
<b>Waterside economizer coil</b>									
Face area (ft <sup>2</sup> )	40.8	40.8	45.8	40.8	45.8	40.8	45.8	40.8	45.8
Rows	4								
FPI	12								
Maximum working pressure (PSIG)	300 standard, 450 optional								
<b>Face loaded filters</b>									
(Quantity) Size	(4) 12×24 and (12) 24×24								
2" filter options	30% (MERV7), 75% (MERV13)								
4" filter options	30% (MERV8), 75% (MERV11), 85% (MERV14)								
Pre-filter options	2"-30% with 4"-65%, 2"-30% with 4"-75%, 2"-30% with 4"-85%								
<b>Evaporator fan<sup>2</sup></b>									
Quantity	1								
Available diameter (Inches)	18, 20, 22, 24, 27, 30, 33, 37								
Maximum motor size (HP)	40								
CAV minimum design (CFM) <sup>3</sup>	8160	8160	9160	8160	9160	8160	9160	8160	9160
VAV minimum design (CFM) <sup>3</sup>	16320	16320	18320	16320	18320	16320	18320	16320	18320
Maximum design (CFM) <sup>3</sup>	24480	24480	27480	24480	27480	24480	27480	24480	27480
<b>Electric heat</b>									
Nominal output (kW)	34, 68 <sup>4</sup>								
Control sequence	2-stage								
<b>Condenser</b>									
Maximum working pressure (PSIG)	300 standard, 450 optional								
Mechanical cooling minimum EWT (°F)	55								
Minimum flow rate (GPM)	104	115	118	129	132	136	139	144	147
Maximum flow rate (GPM)	156	173	176	194	198	204	209	216	221

**NOTE:**

1. Based on AHRI 340/360 standard rating conditions, 80/67°F to the coil, 85/95°F condenser water.
2. Standard fan TSP limit is 6.0 inches of water. Consult your local Daikin sales representative for applications beyond this range.
3. Minimum design airflow calculated for CAV at 200 fpm, VAV at 400 fpm and a maximum design airflow calculated at 600 fpm.
4. Available for 460 volt and 575 volt units only.



**Table 6: SWP 062 through SWP 088 Physical Data**

Data	Large Cabinet			
	062	073	080	088
<b>Compressor</b>				
Quantity	4		6	
Size (HP)	13 (2), 15 (2)	10 (4), 13 (2)	10 (2), 13 (4)	13
Number of refrigeration circuits	4		6	
<b>Evaporator coil</b>				
Coil size		Standard		
Face area (ft <sup>2</sup> )		52.5		
Number of rows	5		6	
FPI		12		
<b>Performance</b>				
Total capacity <sup>1</sup> (MBH)	866	1021	1093	1164
<b>Pre-heating coil</b>				
Hot water coil face area (ft <sup>2</sup> )		56.3 or 55.7		
Available rows		1 or 2		
<b>Waterside economizer coil</b>				
Face area (ft <sup>2</sup> )		52.5		
Rows		4		
FPI		12		
Maximum working pressure (PSIG)		300 standard, 450 optional		
<b>Face loaded filters</b>				
(Quantity) Size		(5) 12×24 and (15) 24×24		
2" filter options		30% (MERV7), 75% (MERV13)		
4" filter options		30% (MERV8), 75% (MERV11), 85% (MERV14)		
Pre-filter options		2"-30% with 4"-65%, 2"-30% with 4"-75%, 2"-30% with 4"-85%		
<b>Evaporator fan<sup>2</sup></b>				
Quantity		1		
Available diameter (Inches)		22, 24, 27, 30, 33, 37		
Maximum motor size (HP)		50		
CAV minimum design (CFM) <sup>3</sup>		10500		
VAV minimum design (CFM) <sup>3</sup>		21000		
Maximum design (CFM) <sup>3</sup>		31500		
<b>Electric heat</b>				
Nominal output (kW)		68		
Control sequence		2-stage		
<b>Condenser</b>				
Maximum working pressure (PSIG)		300 standard, 450 optional		
Mechanical cooling minimum EWT (°F)	55			
Minimum flow rate (GPM)	144	170	182	194
Maximum flow rate (GPM)	217	255	573	291

**NOTE:**

1. Based on AHRI 340/360 standard rating conditions, 80/67°F to the coil, 85/95°F condenser water.
2. Standard fan TSP limit is 6.0 inches of water. Consult your local Daikin sales representative for applications beyond this range.
3. Minimum design airflow calculated for CAV at 200 fpm, VAV at 400 fpm and a maximum design airflow calculated at 600 fpm.

**Table 7: SWP 065 through SWP 130 Physical Data**

Data	Large Tall Cabinet											
	065	073	080	088	099	105	120	130				
<b>Compressor</b>												
Quantity	4	6				8						
Size (HP)	15	10 (4), 13 (2)	10 (2), 13 (4)	13	15	13	13 (4), 15 (4)		15			
Number of refrigeration circuits	4	6				8						
<b>Evaporator coil</b>												
Coil size	Std			Std	Lg	Std	Lg	Std	Lg	Std	Lg	
Face area (ft <sup>2</sup> )	60.9			60.9	71.3	60.9	71.3	60.9	71.3	60.9	71.3	
Number of rows	6											
FPI	12											
<b>Performance</b>												
Total capacity <sup>1</sup> (MBH)	946	1052	1128	1202	1343	1381	1451	1527	1526	1606	1621	1701
<b>Pre-heating coil</b>												
Hot water coil face area (ft <sup>2</sup> )	69.8 or 69.1											
Available rows	1 or 2											
<b>Waterside economizer coil</b>												
Face area (ft <sup>2</sup> )	60.9			60.9	71.3	60.9	71.3	60.9	71.3	60.9	71.3	
Rows	4											
FPI	12											
Maximum working pressure (PSIG)	300 standard, 450 optional											
<b>Face loaded filters</b>												
(Quantity) Size	(20) 24×24											
2" filter options	30% (MERV7), 75% (MERV13)											
4" filter options	30% (MERV8), 75% (MERV11), 85% (MERV14)											
Pre-filter options	2"-30% with 4"-65%, 2"-30% with 4"-75%, 2"-30% with 4"-85%											
<b>Evaporator fan<sup>2</sup></b>												
Quantity	1											
Available diameter (Inches)	24, 27, 30, 33, 37, 40, 44											
Maximum motor size (HP)	50											
CAV minimum design (CFM) <sup>3</sup>	12180			12180	14260	12180	14260	12180	14260	12180	14260	
VAV minimum design (CFM) <sup>3</sup>	24360			24360	28520	24360	28520	24360	28520	24360	28520	
Maximum design (CFM) <sup>3</sup>	36540			36540	42780	36540	42780	36540	42780	36540	42780	
<b>Electric heat</b>												
Nominal output (kW)	68											
Control sequence	2-stage											
<b>Condenser</b>												
Maximum working pressure (PSIG)	300 standard, 450 optional											
Mechanical cooling minimum EWT (°F)	55											
Minimum flow rate (GPM)	158	175	188	200	224	230	242	254	254	268	270	284
Maximum flow rate (GPM)	237	263	282	300	336	345	363	382	382	402	405	425

**NOTE:**

1. Based on AHRI 340/360 standard rating conditions, 80/67°F to the coil, 85/95°F condenser water.
2. Standard fan TSP limit is 6.0 inches of water. Consult your local Daikin sales representative for applications beyond this range.
3. Minimum design airflow calculated for CAV at 200 fpm, VAV at 400 fpm and a maximum design airflow calculated at 600 fpm.

## Unit Weights

**Table 8: Unit and Component Weights for Small and Small Tall Cabinets (lbs.)**

Component Description	Unit Model Size					
	Small Cabinet			Small Tall Cabinet		
	023	028	033	039	044	050
Basic Cabinet <sup>1</sup>	3587	3637	3651	3994	4008	4008
Cooling Coil Section—Drain Pan Only		1045			1081	
Supply Fan/Control Panel Section		1061			993	
Condenser/Compressor Section	1480	1530	1544	1920	1934	1934
Condenser Water Weight	29	31	35	44	47	50
<b>Face Load Filter Rack</b>						
Rack Only		64			67	
2"—MERV 7		15			16	
4"—MERV 8		15			16	
4"—MERV 11		62			63	
4"—MERV 13		62			63	
4"—MERV 14		62			63	
<b>Evaporator Coils</b>						
5 row—12 fpi		372			N/A	
Large 5 row—12 fpi		N/A			440	
<b>Waterside Economizer Coils</b>						
Large 4 row—12 fpi		316			371	
Water Weight		117			152	
<b>Electric Heat</b>						
34 kW		20			20	
<b>Supply Fan Assembly</b>						
13" SWSI		106			N/A	
15" SWSI		110			N/A	
16" SWSI		122			N/A	
18" SWSI		181			181	
20" SWSI		195			195	
22" SWSI		245			245	
24" SWSI		267			267	
27" SWSI		N/A			395	
<b>Supply Fan Motor—ODP</b>						
3 HP		76			76	
5 HP		88			88	
7.5 HP		134			134	
10 HP		158			158	
15 HP		203			203	
20 HP		235			235	
<b>Supply Fan Motor—TEFC</b>						
3 HP		77			77	
5 HP		91			91	
7.5 HP		150			150	
10 HP		184			184	
15 HP		253			253	
20 HP		321			321	
<b>Variable Frequency Drive</b>						
3 HP		14			14	
5 HP		14			14	
7.5 HP		20			20	
10 HP		20			20	
15 HP		35			35	
20 HP		35			35	
<b>Discharge Plenum</b>						
32" High without Sound Baffles				268		
32" High with Sound Baffles				428		

**NOTE:**

1. Basic unit consists of a cooling coil section without coils, a supply fan/control panel section without supply fans, supply fan motors or VFD and a condenser/compressor section.

**Table 9: Unit and Component Weights for Medium and Large Cabinets (lbs.)**

Component Description	Unit Model Size								
	Medium Cabinet					Large Cabinet			
	044	050	056	062	065	062	073	080	088
Basic Cabinet <sup>1</sup>	4733	4747	5136	5136	5136	6179	8507	8563	8619
Cooling Coil Section—Drain Pan Only	1288					1542			
Supply Fan/Control Panel Section	1377					1853			
Condenser/Compressor Section	2067	2081	2470	2470	2470	2784	3506	3534	3562
Condenser Water Weight	52	55	61	64	68	67	85	88	91
<b>Face Load Filter Rack</b>									
Rack Only	95					116			
2"—MERV 7	22					27			
4"—MERV 8	22					27			
4"—MERV 11	91					112			
4"—MERV 13	91					113			
4"—MERV 14	91					113			
<b>Evaporator Coils</b>									
Large 5 row—12 fpi	668					776	—	—	—
Standard 6 row—12 fpi	N/A					—	776	776	776
<b>Waterside Economizer Coils</b>									
Large 4 row—12 fpi	557					654			
Water Weight	250					279			
<b>Electric Heat</b>									
34 kW	20					20			
68 kW	40					40			
<b>Supply Fan Assembly</b>									
18" SWSI	181					N/A			
20" SWSI	195					N/A			
22" SWSI	245					245			
24" SWSI	267					267			
27" SWSI	395					395			
30" SWSI	434					434			
33" SWSI	592					592			
36" SWSI	723					723			
<b>Supply Fan Motor—ODP</b>									
15 HP	203					N/A			
20 HP	235					N/A			
25 HP	290					290			
30 HP	336					336			
40 HP	434					434			
50 HP	N/A					723			
<b>Supply Fan Motor—TEFC</b>									
15 HP	253					N/A			
20 HP	321					N/A			
25 HP	354					354			
30 HP	416					416			
40 HP	538					538			
50 HP	N/A					612			
<b>Variable Frequency Drive</b>									
15 HP	35					N/A			
20 HP	35					N/A			
25 HP	53					53			
30 HP	53					53			
40 HP	53					53			
50 HP	N/A					152			
<b>Discharge Plenum</b>									
32" High without Sound Baffles	320					416			
32" High with Sound Baffles	516					680			

**NOTE:**

1. Basic unit consists of a cooling coil section without coils, a supply fan/control panel section without supply fans, supply fan motors or VFD and a condenser/compressor section.

**Table 10: Unit and Component Weights for Large Tall Cabinets (lbs.)**

Component Description	Unit Model Size							
	Large Tall Cabinet							
	065	073	080	088	099	105	120	130
Basic Cabinet <sup>1</sup>	6476	7199	7227	7255	7255	8300	8300	8300
Cooling Coil Section—Drain Pan Only	1610					1600		
Supply Fan/Control Panel Section	2091					2276		
Condenser/Compressor Section	2776	3498	3526	3554	3554	4424		
Condenser Water Weight	70	85	88	91	102	128	134	141
<b>Face Load Filter Rack</b>								
Rack Only						138		
2"—MERV 7						32		
4"—MERV 8						32		
4"—MERV 11						132		
4"—MERV 13						132		
4"—MERV 14						132		
<b>Evaporator Coils</b>								
Large 5 row—12 fpi	1054	—	—	—	—	—	—	—
Large 6 row—12 fpi	—	1054	1054	1054	1054	1054	1054	1054
<b>Waterside Economizer Coils</b>								
Large 4 row—12 fpi						879		
Water Weight						331		
<b>Electric Heat</b>								
34 kW						20		
68 kW						40		
<b>Supply Fan Assembly</b>								
24" SWSI						267		
27" SWSI						395		
30" SWSI						434		
33" SWSI						592		
36" SWSI						723		
40" SWSI						856		
44" SWSI						1101		
<b>Supply Fan Motor—ODP</b>								
25 HP						290		
30 HP						336		
40 HP						432		
50 HP						494		
60 HP						675		
<b>Supply Fan Motor—TEFC</b>								
25 HP						354		
30 HP						416		
40 HP						538		
50 HP						612		
60 HP						905		
<b>Variable Frequency Drive</b>								
25 HP						53		
30 HP						53		
40 HP						53		
50 HP						152		
60 HP						152		
<b>Discharge Plenum</b>								
32" High without Sound Baffles						416		
32" High with Sound Baffles						680		

**NOTE:**

1. Basic unit consists of a cooling coil section without coils, a supply fan/control panel section without supply fans, supply fan motors or VFD and a condenser/compressor section.



## DX Cooling Capacity Data

**Table 11: SWP 012–SWP033 (Small Cabinet) Cooling Capacity**

Unit	EAT DB/WB (°F)	EWT (°F)	Capacity		LAT		Flow Rate (GPM)
			Total (MBH)	Sensible (MBH)	DB (°F)	WB (°F)	
<b>SWP 023HS</b>							
6 hp & 13 hp Compressors  5-row Standard DX Coil  8,000 cfm  R410A	75.0/62.0	75	291	228	48.9	48.9	87
		85	279	223	49.5	49.5	85
		95	266	217	50.2	50.1	84
	80.0/67.0	75	318	226	54.2	54.1	94
		85	305	221	54.8	54.7	92
		95	291	215	55.4	55.4	90
	85.0/72.0	75	346	223	59.5	59.5	102
		85	332	218	60.1	60.1	100
		95	316	212	60.8	60.7	97
<b>SWP 023HL</b>							
6 hp & 13 hp Compressors 5-row Large DX Coil 8,300 cfm R410A	75.0/62.0	75	298	236	49.1	49.1	71
		85	285	230	49.7	49.7	70
		95	272	224	50.4	50.3	68
	80.0/67.0	75	325	233	54.3	54.3	77
		85	311	227	55.0	54.9	75
		95	296	221	55.6	55.6	74
	85.0/72.0	75	353	230	59.7	59.7	83
		85	338	224	60.3	60.3	81
		95	321	218	61.0	60.9	79
<b>SWP 028HS</b>							
10 hp & 15 hp Compressors  5-row Standard DX Coil  9,500 cfm  R410A	75.0/62.0	75	338	267	49.3	49.2	81
		85	325	261	49.9	49.7	80
		95	309	254	50.5	50.4	79
	80.0/67.0	75	369	264	54.5	54.4	88
		85	354	258	55.1	55.0	86
		95	337	252	55.8	55.6	85
	85.0/72.0	75	401	261	59.9	59.8	95
		85	385	255	60.5	60.3	93
		95	367	249	61.1	60.9	91
<b>SWP 028HL</b>							
10 hp & 15 hp Compressors 5-row Large DX Coil 9,800 cfm R410A	75.0/62.0	75	350	277	49.2	49.1	84
		85	335	270	49.8	49.7	82
		95	320	263	50.4	50.3	81
	80.0/67.0	75	381	274	54.4	54.4	90
		85	365	268	55.0	55.0	89
		95	348	261	55.7	55.6	87
	85.0/72.0	75	414	270	59.8	59.8	97
		85	396	264	60.3	60.3	95
		95	378	257	61.0	60.9	94
<b>SWP 033HS</b>							
2×15 hp Compressors  5-row Standard DX Coil  10,500 cfm  R410A	75.0/62.0	75	394	304	48.6	48.4	95
		85	379	297	49.2	49.0	94
		95	361	289	49.9	49.7	92
	80.0/67.0	75	431	301	53.7	53.6	103
		85	413	294	54.4	54.2	103
		95	394	286	55.1	54.9	100
	85.0/72.0	75	468	296	59.1	59.0	112
		85	449	290	59.7	59.6	109
		95	429	282	60.4	60.3	107
<b>SWP 033HL</b>							
2×15 hp Compressors 5-row Large DX Coil 11,500 cfm R410A	75.0/62.0	75	414	326	49.1	49.0	100
		85	397	318	49.7	49.6	98
		95	379	310	50.3	50.3	96
	80.0/67.0	75	452	323	54.4	54.3	108
		85	433	315	54.9	54.9	106
		95	413	307	55.6	55.5	104
	85.0/72.0	75	491	318	59.7	59.7	116
		85	470	310	60.3	60.2	114
		95	448	302	60.9	60.9	111

**NOTE:**

See Table 17 on page 48 to determine unit capacity at other than nominal cfm.

For a computer-generated, job-specific selection, contact your local Daikin sales representative. For 50 Hz applications, derate the total capacity by 0.89; derate the sensible capacity by 0.94. All capacities are gross and do not account for fan motor heat.

Altitude and/or glycol selections are also available.

**Table 12: SWP 039–SWP050 (Small Tall Cabinet) Cooling Capacity**

Unit	EAT DB/WB (°F)	EWT (°F)	Capacity		LAT		Flow Rate (GPM)
			Total (MBH)	Sensible (MBH)	DB (°F)	WB (°F)	
<b>SWP 039HS</b>							
(2) 10 hp, 15 hp Compressors 5-row Standard DX Coil 13,500 cfm R410A	75.0/62.0	75	491	383	49.0	48.8	118
		85	471	374	49.6	49.4	116
		95	449	365	50.3	50.1	114
	80.0/67.0	75	531	379	54.3	54.2	126
		85	510	370	54.9	54.8	124
		95	486	360	55.6	55.4	122
	85.0/72.0	75	576	373	59.7	59.6	136
		85	552	364	60.3	60.2	133
		95	526	355	60.9	60.8	130
<b>SWP 039HL</b>							
(2) 10 hp, 15 hp Compressors 5-row Large DX Coil 14,000 cfm R410A	75.0/62.0	75	502	395	49.2	49.1	120
		85	481	386	49.8	49.6	118
		95	459	376	50.5	50.3	116
	80.0/67.0	75	542	390	54.5	54.5	129
		85	520	381	55.1	55.0	126
		95	496	371	55.8	55.6	124
	85.0/72.0	75	586	383	60.0	59.9	138
		85	563	375	60.5	60.4	135
		95	536	365	61.1	61.0	133
<b>SWP 044HS</b>							
10 hp, (2) 15 hp Compressors 5-row Standard DX Coil 15,000 cfm R410A	75.0/62.0	75	548	426	49.0	48.7	132
		85	527	416	49.6	49.3	130
		95	503	405	50.3	50.0	128
	80.0/67.0	75	594	422	54.3	54.1	142
		85	571	412	54.9	54.7	139
		95	545	401	55.5	55.3	137
	85.0/72.0	75	643	415	59.7	59.5	152
		85	617	406	60.3	60.1	150
		95	589	395	60.9	60.7	146
<b>SWP 044HL</b>							
10 hp, (2) 15 hp Compressors 5-row Large DX Coil 15,500 cfm R410A	75.0/62.0	75	561	439	49.1	48.9	135
		85	539	429	49.7	49.5	133
		95	514	418	50.4	50.1	130
	80.0/67.0	75	607	434	54.4	54.3	145
		85	583	424	55.0	54.8	142
		95	557	413	55.6	55.4	139
	85.0/72.0	75	657	427	59.8	59.9	155
		85	630	417	60.4	60.3	152
		95	601	406	61.0	60.9	149
<b>SWP 050HL</b>							
(32) 15 hp Compressors 5-row Large DX Coil 17,000 cfm R410A	75.0/62.0	75	623	483	49.0	48.7	150
		85	598	472	49.6	49.3	148
		95	571	459	50.3	49.9	145
	80.0/67.0	75	675	478	54.3	54.1	161
		85	648	466	54.9	54.7	158
		95	618	454	55.6	55.3	155
	85.0/72.0	75	729	470	59.7	59.6	173
		85	699	459	60.3	60.1	170
		95	667	447	60.9	60.7	166

**NOTE:**

See Table 17 on page 48 to determine unit capacity at other than nominal cfm.

For a computer-generated, job-specific selection, contact your local Daikin sales representative. For 50 Hz applications, derate the total capacity by 0.89; derate the sensible capacity by 0.94. All capacities are gross and do not account for fan motor heat.

Altitude and/or glycol selections are also available.

**Table 13: SWP 044–SWP065 (Medium Cabinet) Cooling Capacity**

Unit	EAT		EWT (°F)	Capacity		LAT		Flow Rate (GPM)
	DB/WB (°F)			Total (MBH)	Sensible (MBH)	DB (°F)	WB (°F)	
<b>SWP 044HS</b>								
(2) 10 hp, 15 hp Compressors 5-row Standard DX Coil 16,000 cfm R410A	75.0/62.0	75	583	457	48.9	48.8	139	
		85	559	446	49.5	49.4	137	
		95	532	434	50.2	50.1	134	
	80.0/67.0	75	630	450	54.3	54.2	150	
		85	605	440	54.9	54.8	147	
		95	576	428	55.5	55.4	144	
	85.0/72.0	75	680	442	59.7	59.7	160	
		85	652	432	60.3	60.2	157	
		95	621	421	60.9	60.9	154	
<b>SWP 050HS</b>								
(3) 15 hp Compressors 5-row Standard DX Coil 17,500 cfm R410A	75.0/62.0	75	592	479	50.0	49.9	140	
		85	568	468	50.5	50.4	138	
		95	541	456	51.2	51.0	136	
	80.0/67.0	75	639	475	55.3	55.3	150	
		85	613	462	55.9	55.8	148	
		95	584	450	56.5	56.4	145	
	85.0/72.0	75	691	464	60.7	60.7	161	
		85	663	455	61.2	61.2	158	
		95	631	444	61.8	61.8	155	
<b>SWP 050HL</b>								
(3) 15 hp Compressors 5-row Large DX Coil 18,000 cfm R410A	75.0/62.0	75	656	513	48.9	48.8	157	
		85	629	501	49.6	49.4	154	
		95	599	487	50.2	50.1	151	
	80.0/67.0	75	710	506	54.3	54.4	169	
		85	681	494	54.9	54.8	166	
		95	648	481	55.6	55.4	162	
	85.0/72.0	75	766	497	59.7	59.7	181	
		85	734	486	60.3	60.2	177	
		95	699	473	61.0	60.9	173	
<b>SWP 056HS</b>								
(4) 13 hp Compressors 5-row Standard DX Coil 20,500 cfm R410A	75.0/62.0	75	729	576	49.3	49.2	174	
		85	699	563	49.9	49.8	171	
		95	667	548	50.5	50.4	168	
	80.0/67.0	75	794	571	54.5	54.5	188	
		85	759	556	55.2	55.1	184	
		95	723	542	55.8	55.7	180	
	85.0/72.0	75	864	563	59.9	59.8	203	
		85	825	549	60.5	60.4	198	
		95	784	534	61.2	61.1	193	
<b>SWP 056HL</b>								
(4) 13 hp Compressors 5-row Large DX Coil 20,500 cfm R410A	75.0/62.0	75	736	580	49.1	49.0	175	
		85	705	566	49.8	49.6	172	
		95	673	552	50.4	50.3	169	
	80.0/67.0	75	801	574	54.4	54.3	189	
		85	766	560	55.0	55.0	185	
		95	729	545	55.7	55.6	181	
	85.0/72.0	75	872	566	59.8	59.7	204	
		85	832	552	60.4	60.3	199	
		95	790	537	61.0	61.0	194	
<b>SWP 062HS</b>								
(2) 13 hp, (2) 15 hp Compressors 5-row Standard DX Coil 21,500 cfm R410A	75.0/62.0	75	773	608	49.1	49.0	186	
		85	741	594	49.7	49.6	182	
		95	707	579	50.4	50.2	179	
	80.0/67.0	75	842	602	54.4	54.3	200	
		85	806	587	55.0	54.9	196	
		95	768	572	55.7	55.5	192	
	85.0/72.0	75	915	593	59.8	59.7	216	
		85	875	579	60.4	60.3	211	
		95	833	564	61.0	60.9	206	

**NOTE:**

See Table 17 on page 48 to determine unit capacity at other than nominal cfm.

For a computer-generated, job-specific selection, contact your local Daikin sales representative. For 50 Hz applications, derate the total capacity by 0.89; derate the sensible capacity by 0.94. All capacities are gross and do not account for fan motor heat.

Altitude and/or glycol selections are also available.

**Table 13 continued: SWP 044–SWP065 (Medium Cabinet) Cooling Capacity**

Unit	EAT	EWT (°F)	Capacity		LAT		Flow Rate (GPM)
	DB/WB (°F)		Total (MBH)	Sensible (MBH)	DB (°F)	WB (°F)	
<b>SWP 062HL</b>							
(2) 13 hp, (2) 15 hp Compressors 5-row Large DX Coil 21,500 cfm R410A	75.0/62.0	75	783	619	49.3	49.2	188
		85	751	605	49.9	49.8	184
		95	717	589	50.5	50.4	181
	80.0/67.0	75	852	612	54.5	54.5	202
		85	816	598	55.2	55.1	198
		95	777	582	55.8	55.7	194
	85.0/72.0	75	926	604	59.9	59.8	219
		85	885	589	60.5	60.4	213
		95	842	574	61.2	61.1	208
<b>SWP 065HS</b>							
(4) 15 hp Compressors 5-row Standard DX Coil 22,750 cfm R410A	75.0/62.0	75	825	646	49.0	48.9	199
		85	792	631	49.6	49.5	195
		95	756	615	50.3	50.1	192
	80.0/67.0	75	896	638	54.3	54.2	214
		85	859	624	54.9	54.8	210
		95	819	607	55.6	55.4	206
	85.0/72.0	75	972	629	59.7	59.6	231
		85	931	614	60.3	60.2	221
		95	887	598	61.0	60.8	221
<b>SWP 065HL</b>							
(4) 15 hp Compressors 5-row Large DX Coil 23,000 cfm R410A	75.0/62.0	75	835	654	49.0	48.9	201
		85	801	639	49.6	49.5	197
		95	765	622	50.3	50.1	194
	80.0/67.0	75	906	646	54.3	54.2	216
		85	869	631	54.9	54.8	212
		95	828	615	55.6	55.4	208
	85.0/72.0	75	982	636	59.7	59.6	233
		85	941	621	60.3	60.2	228
		95	896	605	60.9	60.8	223

**NOTE:**

 See [Table 17 on page 48](#) to determine unit capacity at other than nominal cfm.

For a computer-generated, job-specific selection, contact your local Daikin sales representative. For 50 Hz applications, derate the total capacity by 0.89; derate the sensible capacity by 0.94. All capacities are gross and do not account for fan motor heat.

Altitude and/or glycol selections are also available.

**Table 14: SWP 062–SWP088 (Large Cabinet) Cooling Capacity**

Unit	EAT	EWT (°F)	Capacity		LAT		Flow Rate (GPM)
	DB/WB (°F)		Total (MBH)	Sensible (MBH)	DB (°F)	WB (°F)	
<b>SWP 062HS</b>							
(2) 13 hp, (2) 15 hp Compressors 5-row Standard DX Coil 22,000 cfm R410A	75.0/62.0	75	799	627	48.9	48.9	191
		85	765	612	49.6	49.5	187
		95	729	596	50.2	50.1	184
	80.0/67.0	75	868	620	54.2	54.2	206
		85	830	604	54.9	54.8	202
		95	790	588	55.5	55.5	197
	85.0/72.0	75	943	610	59.6	59.6	222
		85	900	595	60.3	60.2	217
		95	855	579	60.9	60.9	211
<b>SWP 073HS</b>							
(4) 13 hp, (2) 15 hp Compressors 6-row Standard DX Coil 27,000 cfm R410A	75.0/62.0	75	969	765	49.1	49.0	230
		85	928	747	49.7	49.6	226
		95	884	727	50.4	50.3	221
	80.0/67.0	75	1048	754	54.5	54.4	247
		85	1004	737	55.0	55.0	242
		95	957	718	55.7	55.6	237
	85.0/72.0	75	1133	742	59.9	59.9	265
		85	1085	724	60.5	60.4	259
		95	1032	706	61.1	61.1	253
<b>SWP 080HS</b>							
(2) 13 hp, (4) 15 hp Compressors 6-row Standard DX Coil 29,000 cfm R410A	75.0/62.0	75	1046	823	49.0	48.9	248
		85	1001	803	49.7	49.6	244
		95	953	782	50.3	50.2	239
	80.0/67.0	75	1134	813	54.4	54.3	267
		85	1085	793	55.0	54.9	262
		95	1033	772	55.6	55.5	256
	85.0/72.0	75	1227	800	59.8	59.7	287
		85	1173	780	60.4	60.3	281
		95	1116	760	61.0	61.0	274
<b>SWP 088HS</b>							
6 hp & 13 hp Compressors 6-row Standard DX Coil 31,000 cfm R410A	75.0/62.0	75	1122	881	49.0	48.9	267
		85	1074	860	49.6	49.5	262
		95	1024	837	50.3	50.1	257
	80.0/67.0	75	1218	871	54.3	54.2	287
		85	1165	850	54.9	54.8	281
		95	1110	827	55.6	55.5	275
	85.0/72.0	75	1320	858	59.7	59.6	309
		85	1261	836	60.3	60.3	302
		95	1200	814	61.0	60.9	295

**NOTE:**

 See [Table 17 on page 48](#) to determine unit capacity at other than nominal cfm.

For a computer-generated, job-specific selection, contact your local McQuay sales representative. For 50 Hz applications, derate the total capacity by 0.89; derate the sensible capacity by 0.94. All capacities are gross and do not account for fan motor heat.

Altitude and/or glycol selections are also available.



**Table 15: SWP 065–SWP130 (Large Tall Cabinet) Cooling Capacity**

Unit	EAT DB/WB (°F)	EWT (°F)	Capacity		LAT		Flow Rate (GPM)
			Total (MBH)	Sensible (MBH)	DB (°F)	WB (°F)	
<b>SWP 065HS</b>							
(4) 15 hp Compressors 6-row Standard DX Coil 24,000 cfm R410A	75.0/62.0	75	868	682	49.0	48.9	208
		85	832	666	49.6	49.5	204
		95	794	649	50.3	50.2	200
	80.0/67.0	75	940	673	54.3	54.3	224
		85	900	657	55.0	54.9	219
		95	856	640	55.6	55.6	214
	85.0/72.0	75	1017	662	59.8	59.7	241
		85	973	646	60.4	60.3	235
		95	925	629	61.0	61.0	229
<b>SWP 073HS</b>							
(4) 10 hp, (2) 13 hp Compressors 6-row Standard DX Coil 27,500 cfm R410A	75.0/62.0	75	983	778	49.1	49.1	233
		85	941	759	49.7	49.7	229
		95	896	739	50.4	50.3	224
	80.0/67.0	75	1050	761	54.6	54.6	24.7
		85	1018	749	55.1	55.1	245
		95	969	730	55.7	55.7	240
	85.0/72.0	75	1148	754	59.9	59.9	268
		85	1099	736	60.5	60.5	262
		95	1046	717	61.2	61.1	256
<b>SWP 080HL</b>							
(2) 10 hp, (4) 13 hp Compressors 6-row Standard DX Coil 29,500 cfm R410A	75.0/62.0	75	1062	837	49.0	49.0	252
		85	1016	817	49.7	49.6	247
		95	967	795	50.4	50.3	242
	80.0/67.0	75	1151	827	54.4	54.3	271
		85	1101	806	55.0	54.9	265
		95	1047	785	55.7	55.6	259
	85.0/72.0	75	1245	813	59.8	59.8	291
		85	1190	793	60.4	60.4	284
		95	1132	773	61.1	61.0	277
<b>SWP 088HS</b>							
(6) 13 hp Compressors 6-row Standard DX Coil 31,500 cfm R410A	75.0/62.0	75	1140	897	49.0	48.9	271
		85	1091	874	49.6	49.5	265
		95	1039	851	50.3	50.2	260
	80.0/67.0	75	1238	886	54.3	54.2	292
		85	1183	864	54.9	54.9	285
		95	1126	841	55.6	55.5	279
	85.0/72.0	75	1340	872	59.7	59.7	314
		85	1280	850	60.3	60.3	306
		95	1217	828	61.0	60.9	299
<b>SWP 099HS</b>							
(6) 15 hp Compressors 6-row Large DX Coil 36,250 cfm R410A	75.0/62.0	75	1297	1024	49.2	49.0	311
		85	1244	1000	49.8	49.6	306
		95	1186	974	50.4	50.3	300
	80.0/67.0	75	1403	1010	54.5	54.4	334
		85	1346	987	55.1	55.0	328
		95	1282	961	55.8	55.6	321
	85.0/72.0	75	1514	992	60.0	59.9	358
		85	1451	969	60.6	60.5	351
		95	1382	945	61.2	61.1	343
<b>SWP 099HL</b>							
(6) 15 hp Compressors 6-row Large DX Coil 36,250 cfm R410A	75.0/62.0	75	1313	1032	49.0	48.9	314
		85	1259	1008	49.6	49.5	309
		95	1200	982	50.2	50.1	303
	80.0/67.0	75	1420	1018	54.3	54.3	338
		85	1362	994	54.9	54.8	331
		95	1297	969	55.6	55.5	324
	85.0/72.0	75	1531	999	59.8	59.8	362
		85	1468	976	60.4	60.3	355
		95	1398	952	61.0	60.9	346

**NOTE:**

See Table 17 on page 48 to determine unit capacity at other than nominal cfm.

For a computer-generated, job-specific selection, contact your local Daikin sales representative. For 50 Hz applications, derate the total capacity by 0.89; derate the sensible capacity by 0.94. All capacities are gross and do not account for fan motor heat.

Altitude and/or glycol selections are also available.

**Table 15 continued: SWP 065–SWP130 (Large Tall Cabinet) Cooling Capacity**

Unit	EAT DB/WB (°F)	EWT (°F)	Capacity		LAT		Flow Rate (GPM)
			Total (MBH)	Sensible (MBH)	DB (°F)	WB (°F)	
<b>SWP 105HS</b>							
(8) 13 hp Compressors 6-row Standard DX Coil 36,500 cfm R410A	75.0/62.0	75	1390	1070	48.2	48.1	333
		85	1334	1045	48.8	48.8	328
		95	1275	1018	49.5	49.4	323
	80.0/67.0	75	1517	1060	53.5	53.4	360
		85	1454	1034	54.1	54.1	353
		95	1387	1007	54.8	54.7	347
	85.0/72.0	75	1654	1046	58.8	58.8	390
		85	1583	1020	59.4	59.4	381
		95	1508	993	60.1	60.1	373
<b>SWP 105HL</b>							
(8) 13 hp Compressors 6-row Large DX Coil 41,000 cfm R410A	75.0/62.0	75	1470	1161	49.1	49.1	350
		85	1407	1132	49.7	49.7	344
		95	1341	1103	50.4	50.3	337
	80.0/67.0	75	1600	1148	54.4	54.3	378
		85	1528	1119	55.0	55.0	369
		95	1452	1090	55.7	55.6	361
	85.0/72.0	75	1741	1133	59.7	59.7	408
		85	1660	1104	60.4	60.3	398
		95	1576	1074	61.1	61.0	388
<b>SWP 120HS</b>							
(4) 13 hp, (4) 15 hp Compressors 6-row Standard DX Coil 36,500 cfm R410A	75.0/62.0	75	1458	1101	47.4	47.4	352
		85	1401	1075	48.1	48.0	347
		95	1339	1047	48.8	48.7	342
	80.0/67.0	75	1592	1091	52.7	52.6	381
		85	1528	1064	53.3	53.3	374
		95	1459	1036	54.0	54.0	368
	85.0/72.0	75	1736	1076	58.0	58.0	412
		85	1664	1050	58.7	58.7	403
		95	1586	1021	59.4	59.4	395
<b>SWP 120HL</b>							
(4) 13 hp, (4) 15 hp Compressors 6-row Large DX Coil 42,000 cfm R410A	75.0/62.0	75	1547	1208	48.7	48.7	371
		85	1481	1178	49.4	49.3	364
		95	1411	1147	50.0	50.0	357
	80.0/67.0	75	1685	1195	54.0	53.9	401
		85	1611	1165	54.6	54.6	392
		95	1533	1134	55.3	55.3	384
	85.0/72.0	75	1833	1178	59.4	59.3	433
		85	1750	1148	60.0	60.0	422
		95	1663	1117	60.7	60.6	412
<b>SWP 130HS</b>							
(8) 15 hp Compressors 6-row Standard DX Coil 36,500 cfm R410A	75.0/62.0	75	1546	1142	46.4	46.3	375
		85	1488	1115	47.1	47.0	370
		95	1423	1085	47.8	47.7	364
	80.0/67.0	75	1687	1131	51.7	51.6	405
		85	1622	1103	52.4	52.3	399
		95	1550	1073	47.8	47.8	364
	85.0/72.0	75	1835	1114	57.1	57.1	438
		85	1763	1087	57.8	57.7	429
		95	1683	1057	58.5	58.5	422
<b>SWP 130HL</b>							
(8) 15 hp Compressors 6-row Large DX Coil 42,000 cfm R410A	75.0/62.0	75	1637	1248	47.8	47.8	394
		85	1569	1217	48.5	48.4	387
		95	1495	1184	49.2	49.2	380
	80.0/67.0	75	1781	1234	53.1	53.1	426
		85	1706	1203	53.8	53.8	409
		95	1624	1170	54.5	54.5	409
	85.0/72.0	75	1934	1215	58.5	58.5	459
		85	1851	1185	59.2	59.2	449
		95	1761	1152	59.9	59.9	439

**NOTE:**

 See [Table 17 on page 48](#) to determine unit capacity at other than nominal cfm.

For a computer-generated, job-specific selection, contact your local Daikin sales representative. For 50 Hz applications, derate the total capacity by 0.89; derate the sensible capacity by 0.94. All capacities are gross and do not account for fan motor heat.

Altitude and/or glycol selections are also available.

# Waterside Economizer Capacity

**Table 16: Waterside Economizer Coil Face Area**

17.2 Square Feet									
EWT (°F)	EAT (°F)	Nominal Airflow (cfm)	Flow Rate (gpm)	Capacity		Nominal Airflow (cfm)	Flow Rate (cfm)		Capacity (gpm)
	DB/WB			Total (Btu/hr)	Sensible (Btu/hr)		Total (Btu/hr)	Sensible (Btu/hr)	
45	75.0/62.0	4300	43.0	118215	104308	8750	98.4	247233	212158
			35.7	105670	98166		81.7	231712	204722
			28.4	89506	88546		65.0	210613	194026
	80.0/67.0		43.0	153149	113374		98.4	325916	233385
			35.7	133765	105547		81.7	301172	223270
			28.4	109640	95570		65.0	268225	209766
55	75.0/62.0	4300	43.0	76546	76546	8750	98.4	15226	152261
			35.7	71725	71725		81.7	147128	147128
			28.4	63936	63936		98.4	138920	138920
	80.0/67.0		43.0	997707	92120		81.7	201228	183427
			35.7	91330	87908		65.0	190980	178438
			28.4	80220	80201		98.4	176565	170614
25.2 Square Feet									
EWT (°F)	EAT (°F)	Nominal Airflow (cfm)	Flow Rate (gpm)	Capacity		Nominal Airflow (cfm)	Flow Rate (cfm)		Capacity (gpm)
	DB/WB			Total (Btu/hr)	Sensible (Btu/hr)		Total (Btu/hr)	Sensible (Btu/hr)	
45	75.0/62.0	5750	70.8	174932	147468	11250	202.5	328039	278466
			58.8	158718	140000		168.0	307473	268743
			46.8	137193	129347		133.4	278405	254363
	80.0/67.0		70.8	230503	162275		202.5	434409	307307
			58.8	205708	152163		168.0	400795	293543
			46.8	172394	138737		133.4	355858	275180
55	75.0/62.0	5750	70.8	107987	107987	11250	202.5	200490	200490
			58.8	103013	103013		168.0	193879	193879
			46.8	94517	94517		133.4	183078	183078
	80.0/67.0		70.8	145162	128577		202.5	267384	240686
			58.8	134265	12384		168.0	253334	234147
			46.8	119858	116468		133.4	234216	224149
29.8 Square Feet									
EWT (°F)	EAT (°F)	Nominal Airflow (cfm)	Flow Rate (gpm)	Capacity		Nominal Airflow (cfm)	Flow Rate (cfm)		Capacity (gpm)
	DB/WB			Total (Btu/hr)	Sensible (Btu/hr)		Total (Btu/hr)	Sensible (Btu/hr)	
45	75.0/62.0	10000	120.1	300141	252991	12500	150.6	369070	311969
			99.7	277844	242600		125.1	345207	300757
			79.4	247291	227625		99.2	311526	284209
	80.0/67.0		120.1	396773	279042		150.6	488735	344393
			99.7	361929	264763		125.1	450654	328782
			79.4	314626	245527		99.2	376624	298517
55	75.0/62.0	10000	120.1	183343	183343	12500	150.6	224803	224803
			99.7	176480	176480		125.1	217345	217345
			79.4	165073	165073		99.2	204979	204979
	80.0/67.0		120.1	246079	219190		150.6	300807	269528
			99.7	231002	212437		125.1	284619	262106
			79.4	210726	202139		99.2	262399	250687
40.8 Square Feet									
EWT (°F)	EAT (°F)	Nominal Airflow (cfm)	Flow Rate (gpm)	Capacity		Nominal Airflow (cfm)	Flow Rate (cfm)		Capacity (gpm)
	DB/WB			Total (Btu/hr)	Sensible (Btu/hr)		Total (Btu/hr)	Sensible (Btu/hr)	
45	75.0/62.0	11250	138.4	312851	268478	16500	200.9	518514	426470
			115.0	297133	260929		166.8	490321	413441
			91.3	275216	249921		132.4	450026	394389
	80.0/67.0		138.4	414192	296028		200.9	689345	473235
			115.0	387874	285299		166.8	647073	455704
			91.3	353829	271344		132.4	584177	429857
55	75.0/62.0	11250	138.4	191437	191437	16500	200.9	305575	305575
			115.0	186084	186084		166.8	297975	297975
			91.3	177930	177930		132.4	285222	285222
	80.0/67.0		138.4	252970	231305		200.9	418034	365034
			115.0	242136	225955		166.8	398913	356710
			91.3	227979	218163		132.4	372003	344165

NOTE: See Table 18 on page 48 to determine capacity at other than nominal cfm.

Table 16 continued: Waterside Economizer Coil Face Area

45.2 Square Feet									
EWT (°F)	EAT (°F)	Nominal Airflow (cfm)	Flow Rate (gpm)	Capacity		Nominal Airflow (cfm)	Flow Rate (cfm)		Capacity (gpm)
	DB/WB			Total (Btu/hr)	Sensible (Btu/hr)		Total (Btu/hr)	Sensible (Btu/hr)	
45	75.0/62.0	12500	155.4	410014	333157	16500	202.5	526221	430876
			129.0	382469	320590		168.0	495046	416563
			102.3	344216	302774		133.4	453219	396846
	80.0/67.0		155.4	546475	370822		202.5	699525	478358
			129.0	505143	353584		168.0	654992	459848
			102.3	445328	329064		133.4	588178	432393
55	75.0/62.0	12500	155.4	240254	240254	16500	202.5	309206	309206
			129.0	233413	233413		168.0	301287	301287
			102.3	221426	221426		133.4	287860	287860
	80.0/67.0		155.4	332781	285581		202.5	425016	368879
			129.0	314692	278020		168.0	404552	360100
			102.3	288623	266420		133.4	375762	346898

52.5 Square Feet									
EWT (°F)	EAT (°F)	Nominal Airflow (cfm)	Flow Rate (gpm)	Capacity		Nominal Airflow (cfm)	Flow Rate (cfm)		Capacity (gpm)
	DB/WB			Total (Btu/hr)	Sensible (Btu/hr)		Total (Btu/hr)	Sensible (Btu/hr)	
45	75.0/62.0	15500	191.3	530260	422617	22000	267.1	731367	588143
			158.9	504119	410660		221.0	696784	572268
			126.1	464227	392287		176.2	647897	549552
	80.0/67.0		191.3	711594	473799		267.1	979631	657637
			158.9	669318	455923		221.0	925183	634763
			126.1	608158	430457		176.2	847943	602685
55	75.0/62.0	15500	191.3	301945	301945	22000	267.1	419653	419653
			158.9	295956	295956		221.0	411289	411289
			126.1	285323	285323		176.2	397647	397647
	80.0/67.0		191.3	426964	359394		267.1	586400	500035
			158.9	408475	351794		221.0	562770	490066
			126.1	381148	340123		176.2	529279	475352

60.9 Square Feet									
EWT (°F)	EAT (°F)	Nominal Airflow (cfm)	Flow Rate (gpm)	Capacity		Nominal Airflow (cfm)	Flow Rate (cfm)		Capacity (gpm)
	DB/WB			Total (Btu/hr)	Sensible (Btu/hr)		Total (Btu/hr)	Sensible (Btu/hr)	
45	75.0/62.0	16500	207.3	571870	453820	32000	391.7	1003513	820997
			172.0	542915	440594		325.6	958766	800336
			136.5	498560	420239		258.3	903504	774109
	80.0/67.0		207.3	768359	509542		391.7	1339061	913508
			172.0	720933	489427		325.6	1277444	887940
			136.5	653719	461401		258.3	1183607	849179
55	75.0/62.0	16500	207.3	324297	324297	32000	391.7	584577	584577
			172.0	317813	317813		325.6	572669	572669
			136.5	306263	306263		258.3	554618	554618
	80.0/67.0		207.3	461349	385934		391.7	804567	700005
			172.0	439485	377081		325.6	773282	686291
			136.5	410083	364614		258.3	732310	667233

71.3 Square Feet									
EWT (°F)	EAT (°F)	Nominal Airflow (cfm)	Flow Rate (gpm)	Capacity		Nominal Airflow (cfm)	Flow Rate (cfm)		Capacity (gpm)
	DB/WB			Total (Btu/hr)	Sensible (Btu/hr)		Total (Btu/hr)	Sensible (Btu/hr)	
45	75.0/62.0	24750	312.1	834084	667291	32000	402.0	1037546	839692
			259.3	797101	650336		333.0	991370	818465
			264.8	1119379	747621		264.8	931326	790353
	80.0/67.0		312.1	1119379	747621		402.0	1388369	937345
			259.3	1059374	722329		333.0	1318009	907963
			264.8	755519	681094		264.8	1221011	867762
55	75.0/62.0	24750	312.1	475642	475642	32000	402.0	597600	597600
			259.3	466859	466859		333.0	585855	585855
			264.8	669195	566903		264.8	568232	568232
	80.0/67.0		312.1	669195	566903		402.0	829035	713591
			259.3	642967	555976		333.0	797971	700186
			264.8	732310	667233		264.8	755519	681094

NOTE: See Table 18 on page 48 to determine capacity at other than nominal cfm.

**Table 17: Waterside Economizer Capacity Correction Factors**

Description	Percent Standard CFM								
	-20%	-15%	-10%	-5%	Standard	5%	10%	15%	20%
Total Capacity	0.892	0.920	0.947	0.975	1.000	1.025	1.048	1.071	1.093
Sensible Capacity	0.848	0.886	0.925	0.963	1.000	1.037	1.072	1.107	1.142

**Table 18: DX Cooling Capacity Correction Multipliers**

Description	Percent Standard CFM								
	-20%	-15%	-10%	-5%	Standard	5%	10%	15%	20%
Total Capacity	0.957	0.969	0.981	0.991	1.000	1.009	1.017	1.023	1.030
Sensible Capacity	0.895	0.921	0.948	0.974	1.000	1.026	1.052	1.077	1.102
Compressor Motor kW	0.987	0.989	0.996	0.998	1.000	1.004	1.006	1.008	1.011



## Heating Capacity Data

### Hot Water Coil Capacity (2-row)<sup>1</sup>

**Table 19: Entering Water 160°F and Entering Air 60°F**

Cabinet Size	Minimum Coil Face Area (ft <sup>2</sup> ) <sup>2</sup>	Nominal Air Flow (cfm)	Total Capacity (MBH)	LWT (°F)	LBD (°F)	Flow Rate (gpm)	Air Pressure Drop (in. wg)
Small	19.8	4300	241.3	125.8	111.3	14	0.09
		5750	312.2	126.9	109.7	19	0.15
		8750	441.4	129.2	106.1	29	0.30
Small Tall	19.8	5750	312.2	126.9	109.7	19	0.15
		10000	490.2	130.1	104.8	33	0.37
		11250	537.0	130.9	103.7	37	0.45
		12500	581.8	131.6	102.6	41	0.53
Medium	32.3	11250	613.3	126.8	109.9	37	0.20
		12500	667.9	127.4	108.9	41	0.24
		16500	831.8	129.3	106.1	54	0.38
Large	36.7	15500	836.5	127.1	109.4	51	0.34
		16500	879.0	128.5	108.7	54	0.38
		22000	1097.8	129.6	105.6	72	0.61
Large Tall	45.8	16500	919.2	126.0	110.9	54	0.21
		24750	1266.3	128.8	106.8	81	0.41
		32000	1536.9	130.7	103.9	105	0.63
		32500	1554.6	130.8	103.7	107	0.65

**NOTE:**

- Based on 12 fpi aluminum HI-F5 fins with single serpentine.
- Smallest standard coil face area available using Daikin Vision™ air handling unit platform.

### Steam Coil Capacity<sup>1</sup>

**Table 20: Steam Pressure 5 psi and Entering Air 60°F**

Cabinet Size	Minimum Coil Face Area (ft <sup>2</sup> ) <sup>2</sup>	Nominal Air Flow (cfm)	Total Capacity (MBH)	LBD (°F)	Air Pressure Drop (in. wg)
Small	19.8	4300	227.5	119.0	0.03
		5750	330.1	112.5	0.05
		8750	420.1	103.9	0.10
Small Tall	19.8	5750	330.1	112.5	0.05
		10000	452.0	101.3	0.13
		11250	481.4	99.1	0.16
		12500	508.9	97.2	0.20
Medium	32.3	11250	598.2	108.6	0.07
		12500	635.4	106.5	0.08
		16500	740.8	101.1	0.13
Large	36.7	15500	758.5	104.8	0.12
		16500	785.3	103.5	0.13
		22000	916.9	98.1	0.23
Large Tall	45.8	16500	865.8	108.0	0.07
		24750	1083.9	100.0	0.15
		32000	1239.8	95.4	0.24
		32500	1249.7	95.2	0.24

**NOTE:**

- Based on 5 psi steam pressure and 6 fpi aluminum HI-F5 fins.
- Smallest standard coil face area available using Daikin Vision™ air handling unit platform.

### Electric Heat

**Table 21: Electric Heat – 60 Hz, 3 Phase**

SWP Unit Size	208 V / 60 Hz / 3 Phase			230 V / 60 Hz / 3 Phase			460 V / 60 Hz / 3 Phase			575 V / 60 Hz / 3 Phase		
	kW	MBH	FLA	kW	MBH	FLA	kW	MBH	FLA	kW	MBH	FLA
023 through 035	27.8	94	77.2	34.0	116	85.6	34.0	116	42.8	34.0	116	34.2
039 through 050	27.8	94	77.2	34.0	116	85.6	68.0	232	85.6	68.0	232	68.4
044 through 066	27.8	94	77.2	34.0	116	85.6	68.0	232	85.6	68.0	232	68.4
062 through 088	55.6	190	154.4	68.0	232	170.9	68.0	232	85.6	68.0	232	68.4
065 through 130	55.6	190	154.4	68.0	232	170.9	68.0	232	85.6	68.0	232	68.4

## Component Pressure Drops

**Table 22: SWP 023 through 033 (pressure drop in inches wg)**

Nominal Air Flow (cfm)	Standard Coil – 17.2 ft <sup>2</sup>		Filters						Discharge Plenum	
	Evaporator	Economizer	2", 30%	2", 75%	4", 30%	4", 65%	4", 75%	2", 85%	Left & Right	Front & Back
4000	0.26	0.13	0.09	0.11	0.09	0.14	0.07	0.24	0.01	0.00
6000	0.48	0.25	0.18	0.20	0.16	0.25	0.13	0.43	0.01	0.01
8000	0.73	0.41	0.31	0.31	0.25	0.40	0.21	0.64	0.03	0.01
10000	1.02	0.6	0.45	0.42	0.34	0.57	0.29	0.88	0.04	0.01
Nominal Air Flow (cfm)	Large Coil – 25.2 ft <sup>2</sup>		Filters						Discharge Plenum	
	Evaporator	Economizer	2", 30%	2", 75%	4", 30%	4", 65%	4", 75%	2", 85%	Left & Right	Front & Back
6000	0.27	0.13	0.09	0.11	0.10	0.14	0.08	0.25	0.01	0.01
8000	0.41	0.21	0.16	0.17	0.14	0.22	0.12	0.37	0.02	0.01
10000	0.58	0.31	0.23	0.24	0.20	0.32	0.16	0.51	0.04	0.01
12000	0.75	0.43	0.32	0.32	0.26	0.42	0.21	0.66	0.06	0.02
14000	0.95	0.56	0.42	0.40	0.32	0.53	0.27	0.82	0.08	0.03
16000	1.11	0.6	0.53	0.48	0.39	0.65	0.33	0.99	0.10	0.04

**NOTE:**

DX pressure drops are wet coil and economizers are dry coil.

All units must have a DX coil pressure drop.

Based on 32" high plenum with maximum allowed opening.

**Table 23: SWP 039 through 050 (pressure drop in inches wg)**

Nominal Air Flow (cfm)	Standard Coil – 25.2 ft <sup>2</sup>		Filters						Discharge Plenum	
	Evaporator	Economizer	2", 30%	2", 75%	4", 30%	4", 65%	4", 75%	2", 85%	Left & Right	Front & Back
6000	0.27	0.13	0.09	0.11	0.10	0.14	0.08	0.25	0.01	0.01
8000	0.41	0.21	0.16	0.17	0.14	0.22	0.12	0.37	0.03	0.01
10000	0.55	0.31	0.23	0.24	0.20	0.32	0.16	0.51	0.04	0.01
12000	0.72	0.43	0.32	0.32	0.26	0.42	0.21	0.66	0.06	0.02
16000	0.88	0.56	0.42	0.40	0.32	0.53	0.27	0.82	0.08	0.03
Nominal Air Flow (cfm)	Large Coil – 29.8 ft <sup>2</sup>		Filters						Discharge Plenum	
	Evaporator	Economizer	2", 30%	2", 75%	4", 30%	4", 65%	4", 75%	2", 85%	Left & Right	Front & Back
10000	0.45	0.24	0.17	0.19	0.16	0.24	0.13	0.40	0.04	0.01
12000	0.59	0.32	0.24	0.25	0.20	0.32	0.17	0.52	0.06	0.02
14000	0.74	0.42	0.31	0.31	0.25	0.41	0.21	0.65	0.08	0.03
16000	0.88	0.53	0.39	0.38	0.31	0.50	0.25	0.78	0.10	0.04

**NOTE:**

DX pressure drops are wet coil and economizers are dry coil.

All units must have a DX coil pressure drop.

Based on 32" high plenum with maximum allowed opening.

**Table 24: SWP 044 through 065 (pressure drop in inches wg)**

Nominal Air Flow (cfm)	Standard Coil – 40.8 ft <sup>2</sup>		Filters						Discharge Plenum	
	Evaporator	Economizer	2", 30%	2", 75%	4", 30%	4", 65%	4", 75%	2", 85%	Left & Right	Front & Back
10000	0.28	0.14	0.10	0.12	0.10	0.15	0.08	0.26	0.03	0.01
12000	0.37	0.19	0.14	0.16	0.13	0.20	0.10	0.33	0.05	0.01
14000	0.46	0.24	0.18	0.20	0.16	0.25	0.13	0.42	0.06	0.02
16000	0.48	0.31	0.23	0.24	0.19	0.31	0.16	0.50	0.08	0.02
18000	0.65	0.38	0.28	0.28	0.23	0.37	0.19	0.59	0.10	0.03
20000	0.76	0.45	0.34	0.33	0.27	0.44	0.22	0.69	0.13	0.04
22000	0.86	0.53	0.40	0.38	0.31	0.51	0.26	0.79	0.16	0.04
24000	0.98	0.61	0.46	0.43	0.35	0.58	0.29	0.89	0.18	0.05
Nominal Air Flow (cfm)	Large Coil – 45.8 ft <sup>2</sup>		Filters						Discharge Plenum	
	Evaporator	Economizer	2", 30%	2", 75%	4", 30%	4", 65%	4", 75%	2", 85%	Left & Right	Front & Back
12000	0.32	0.16	0.11	0.13	0.11	0.17	0.09	0.28	0.05	0.01
14000	0.40	0.21	0.15	0.17	0.14	0.21	0.11	0.35	0.06	0.02
16000	0.55	0.26	0.19	0.20	0.17	0.26	0.13	0.43	0.08	0.02
18000	0.56	0.32	0.23	0.24	0.20	0.31	0.16	0.50	0.10	0.03
20000	0.64	0.38	0.27	0.28	0.23	0.37	0.19	0.58	0.13	0.04
22000	0.74	0.44	0.32	0.32	0.26	0.42	0.22	0.67	0.16	0.04
24000	0.84	0.51	0.38	0.36	0.29	0.48	0.25	0.76	0.18	0.05
26000	0.94	0.59	0.43	0.41	0.33	0.55	0.28	0.85	0.22	0.06

**NOTE:**

DX pressure drops are wet coil and economizers are dry coil.

All units must have a DX coil pressure drop.

Based on 32" high plenum with maximum allowed opening.

**Table 25: SWP 062 through 088 (pressure drop in inches wg)**

Nominal Air Flow (cfm)	Standard Coil – 52.5 ft <sup>2</sup>		Filters						Discharge Plenum	
	Evaporator	Economizer	2", 30%	2", 75%	4", 30%	4", 65%	4", 75%	2", 85%	Left & Right	Front & Back
12000	0.26	0.12	0.09	0.11	0.09	0.14	0.07	0.23	0.03	0.01
14000	0.38	.012	0.12	0.14	0.11	0.17	0.09	0.29	0.04	0.01
16000	0.45	0.16	0.15	0.16	0.14	0.21	0.11	0.35	0.05	0.01
18000	0.53	0.19	0.18	0.20	0.16	0.25	0.13	0.42	0.07	0.02
20000	0.62	0.23	0.22	0.23	0.19	0.30	0.15	0.48	0.09	0.02
22000	0.70	0.27	0.26	0.26	0.21	0.34	0.18	0.55	0.10	0.03
24000	0.80	0.31	0.30	0.30	0.24	0.39	0.20	.062	0.12	0.03
26000	0.91	0.35	0.34	0.33	0.27	0.44	0.23	0.70	0.14	0.04
28000	1.01	0.40	0.39	0.37	0.30	0.50	0.25	0.78	0.17	0.04
30000	1.13	0.45	0.44	0.41	0.33	0.55	0.28	0.86	0.19	0.05

**NOTE:**

DX pressure drops are wet coil and economizers are dry coil.  
 All units must have a DX coil pressure drop.  
 Based on 32" high plenum with maximum allowed opening.

**Table 26: SWP 065 through 130 (pressure drop in inches wg)**

Nominal Air Flow (cfm)	Standard Coil – 60.9 ft <sup>2</sup>		Filters						Discharge Plenum	
	Evaporator	Economizer	2", 30%	2", 75%	4", 30%	4", 65%	4", 75%	2", 85%	Left & Right	Front & Back
16000	0.36	0.16	0.11	0.13	0.11	0.17	0.09	0.29	0.04	0.01
18000	0.43	0.19	0.14	0.16	0.13	0.20	0.11	0.34	0.05	0.02
20000	0.52	0.23	0.17	0.18	0.15	0.24	0.12	0.39	0.06	0.02
22000	0.60	0.27	0.20	.021	0.17	0.27	0.14	0.45	0.08	0.03
24000	0.68	0.31	0.23	0.24	0.20	0.31	0.16	0.51	0.09	0.03
26000	0.77	0.35	0.26	0.27	0.22	0.35	0.18	0.57	0.11	0.04
28000	0.86	0.40	0.30	0.30	0.24	0.40	0.20	0.63	0.13	0.04
30000	0.94	0.45	0.34	0.33	0.27	0.44	0.22	0.69	0.15	0.05
32000	1.03	0.51	0.38	0.37	0.30	0.49	0.25	0.75	0.17	0.06
34000	1.13	0.56	0.42	0.40	0.32	0.53	0.27	0.83	0.19	0.06
36000	1.22	0.62	0.47	0.43	0.35	0.58	0.29	0.90	0.21	0.07
Nominal Air Flow (cfm)	Large Coil – 71.3 ft <sup>2</sup>		Filters						Discharge Plenum	
	Evaporator	Economizer	2", 30%	2", 75%	4", 30%	4", 65%	4", 75%	2", 85%	Left & Right	Front & Back
18000	0.34	0.15	0.10	0.12	0.10	0.16	0.08	0.27	0.05	0.02
20000	0.41	0.17	0.13	0.15	0.12	0.19	0.10	0.31	0.06	0.02
22000	0.48	0.20	0.15	0.17	0.14	0.21	0.11	0.36	0.08	0.03
24000	0.54	0.24	0.17	0.19	0.16	0.25	0.13	0.40	0.09	0.03
26000	0.61	0.27	0.20	0.21	0.18	0.28	0.14	0.45	0.11	0.04
28000	0.68	0.31	0.23	0.24	0.20	0.31	0.16	0.50	0.13	0.04
30000	0.75	0.35	0.26	0.26	0.22	0.35	0.18	0.55	0.15	0.05
32000	0.83	0.39	0.29	0.29	0.24	0.38	0.19	0.61	0.17	0.06
34000	0.90	0.43	0.32	0.32	0.26	0.42	0.21	0.66	0.19	0.06
36000	0.97	0.47	0.35	0.34	0.28	0.46	0.23	0.72	0.21	0.07
38000	1.04	0.52	0.39	0.37	0.30	0.50	0.25	0.78	0.23	0.08
40000	1.13	0.57	0.43	0.40	.032	0.54	0.27	0.83	0.26	0.09
42000	1.21	0.62	0.46	0.43	0.35	0.58	0.29	0.89	0.28	0.10

**NOTE:**

DX pressure drops are wet coil and economizers are dry coil.  
 All units must have a DX coil pressure drop.  
 Based on 32" high plenum with maximum allowed opening.

## Total Unit Water Pressure Drop

### SWP023 through SWP033

Figure 24: Mechanical Cooling Only

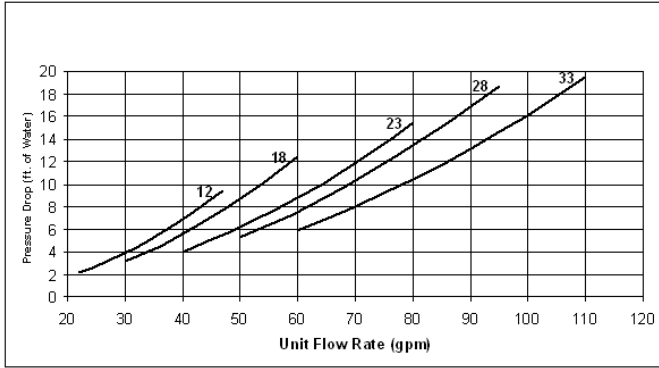

Figure 26: Mechanical Cooling and WRV

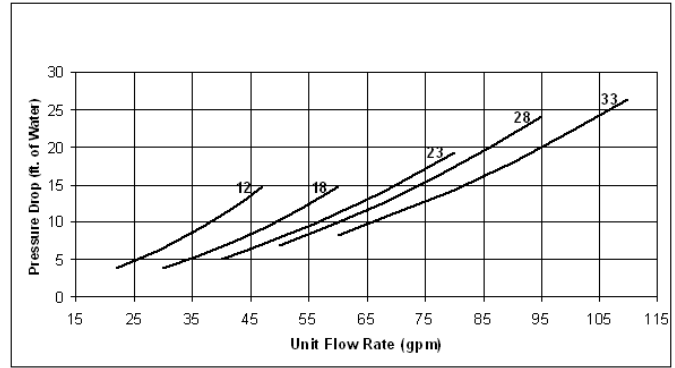

Figure 25: Standard Economizer Coil

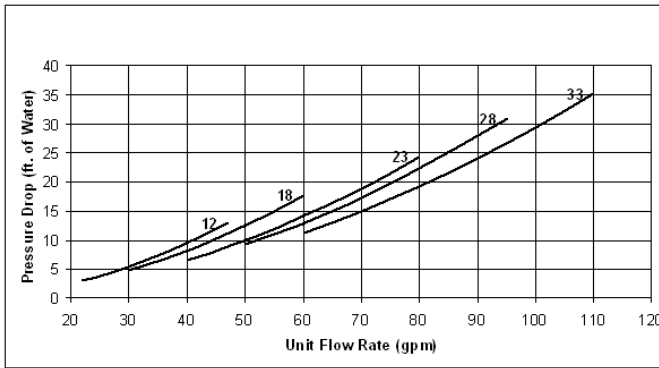
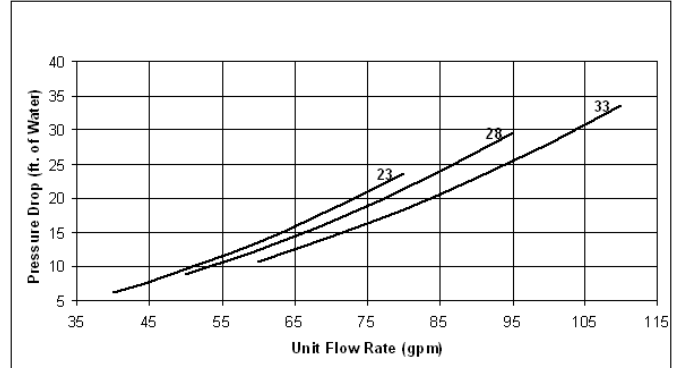

Figure 27: Large Economizer Coil



**NOTE:** Total water pressure drop varies depending on a units selected options. Only use the specific chart which reflects your unit. The above figures illustrate total water pressure drop (WPD) for each associated model number.

- Use [Figure 24](#) if no water side economizer coil or water regulating valve is provided
- Use [Figure 25](#) for standard economizer coils and [Figure 27](#) for large economizer coils
- Use [Figure 26](#) if a water regulating valve is provided

SWP039 through SWP050

Figure 28: Mechanical Cooling Only

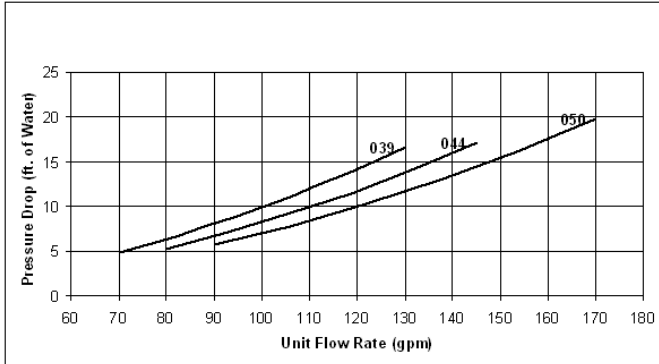

Figure 30: Mechanical Cooling and WRV

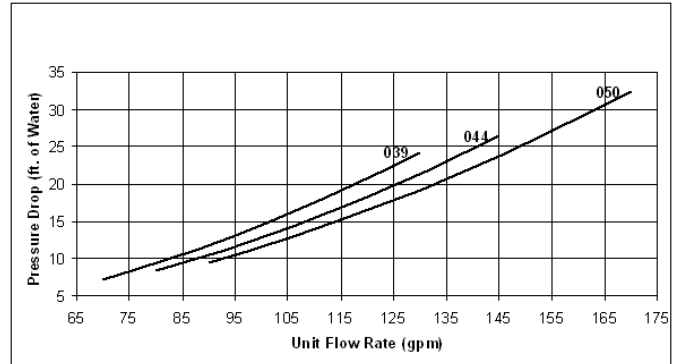

Figure 29: Standard Economizer Coil

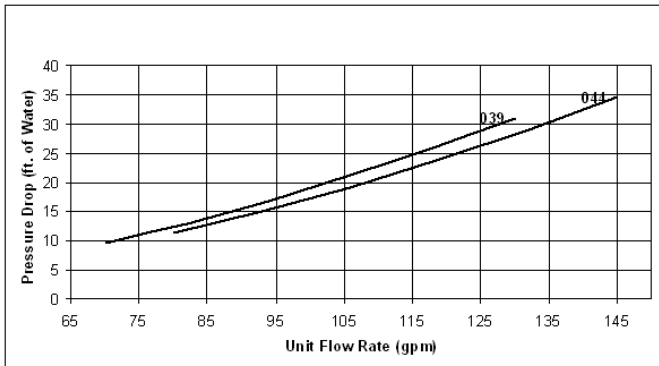
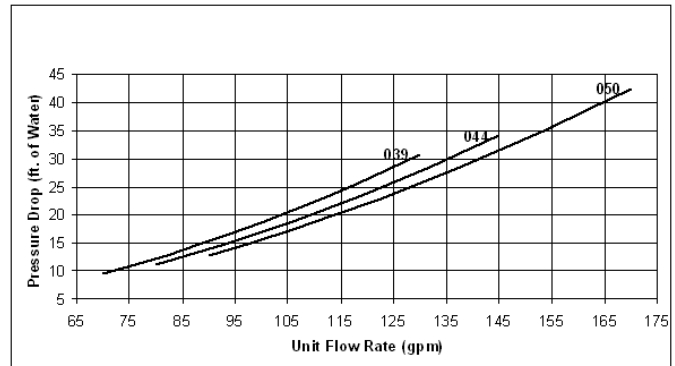

Figure 31: Large Economizer Coil



**NOTE:** Total water pressure drop varies depending on a units selected options. Only use the specific chart which reflects your unit. The above figures illustrate total water pressure drop (WPD) for each associated model number.

- Use [Figure 28](#) if no water side economizer coil or water regulating valve is provided
- Use [Figure 29](#) for standard economizer coils and [Figure 31](#) for large economizer coils
- Use [Figure 30](#) if a water regulating valve is provided



SWP044 through SWP055

Figure 32: Mechanical Cooling Only

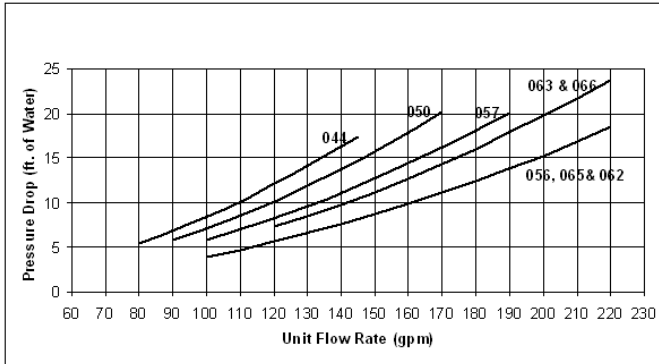

Figure 34: Mechanical Cooling and WRV

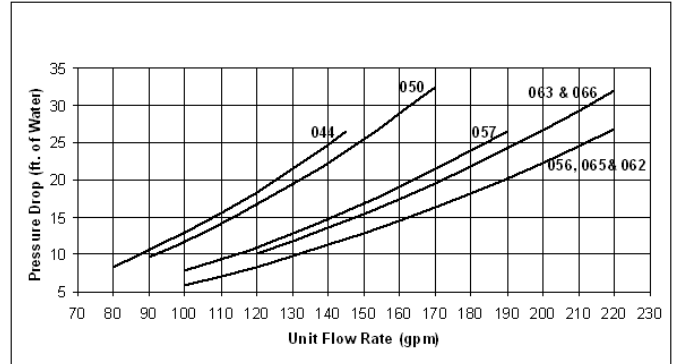

Figure 33: Standard Economizer Coil

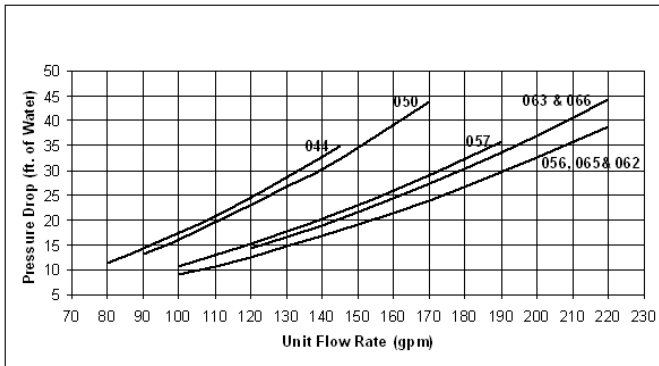
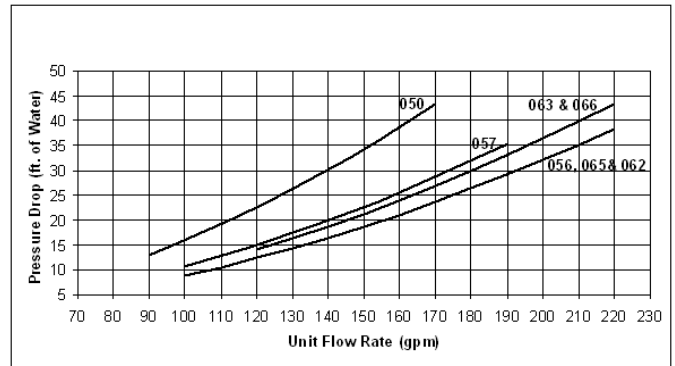

Figure 35: Large Economizer Coil



**NOTE:** Total water pressure drop varies depending on a units selected options. Only use the specific chart which reflects your unit. The above figures illustrate total water pressure drop (WPD) for each associated model number.

- Use [Figure 32](#) if no water side economizer coil or water regulating valve is provided
- Use [Figure 33](#) for standard economizer coils and [Figure 35](#) for large economizer coils
- Use [Figure 34](#) if a water regulating valve is provided

SWP062 through SWP088

Figure 36: Mechanical Cooling Only

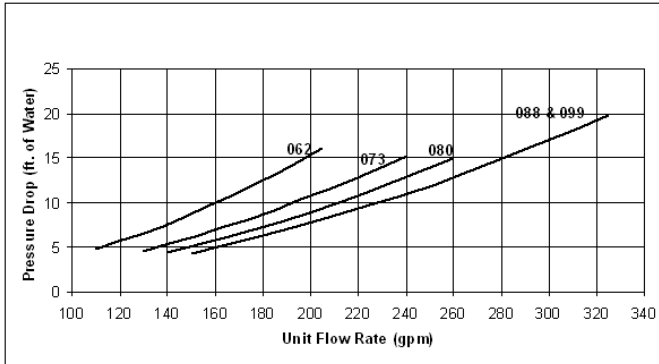

Figure 38: Mechanical Cooling and WRV

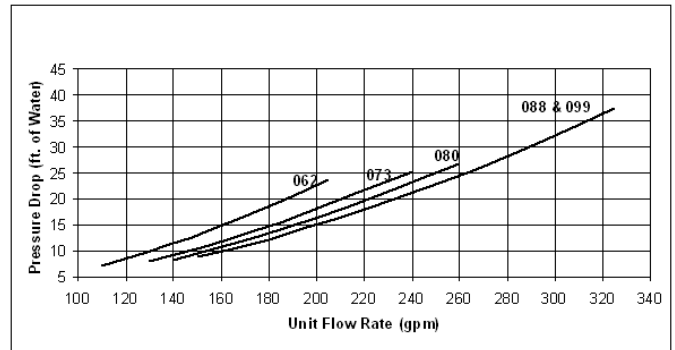
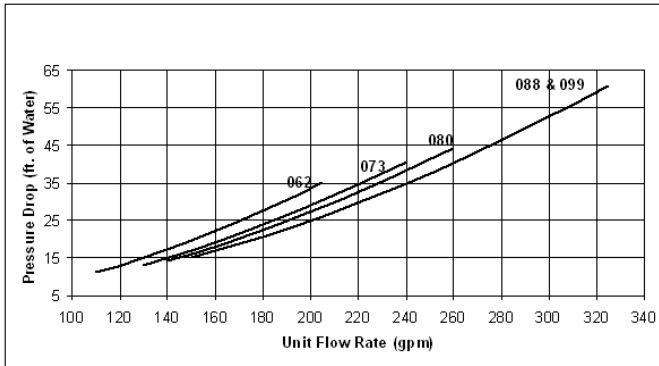

Figure 37: Standard Economizer Coil



**NOTE:** Total water pressure drop varies depending on a units selected options. Only use the specific chart which reflects your unit. The above figures illustrate total water pressure drop (WPD) for each associated model number.

- Use [Figure 36](#) if no water side economizer coil or water regulating valve is provided
- Use [Figure 37](#) for standard economizer coils
- Use [Figure 38](#) if a water regulating valve is provided

SWP065 through SWP130

Figure 39: Mechanical Cooling Only

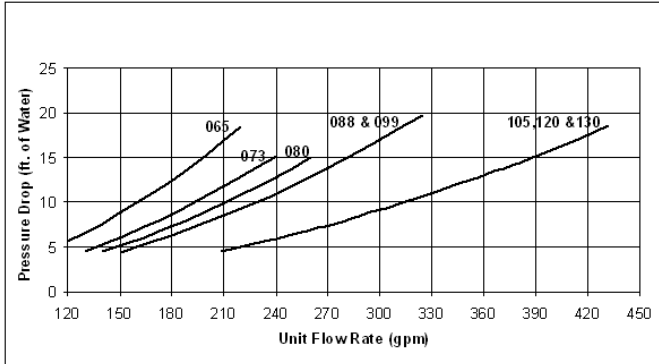

Figure 41: Mechanical Cooling and WRV

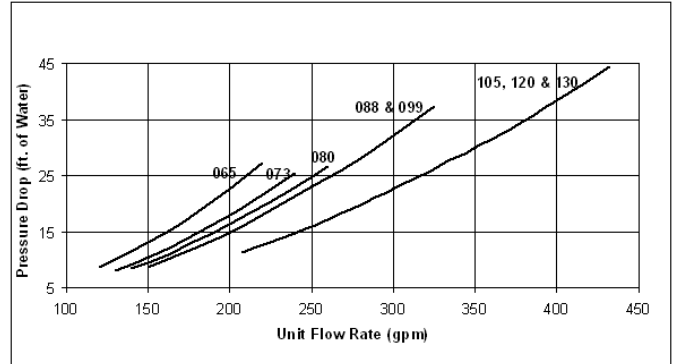

Figure 40: Standard Economizer Coil

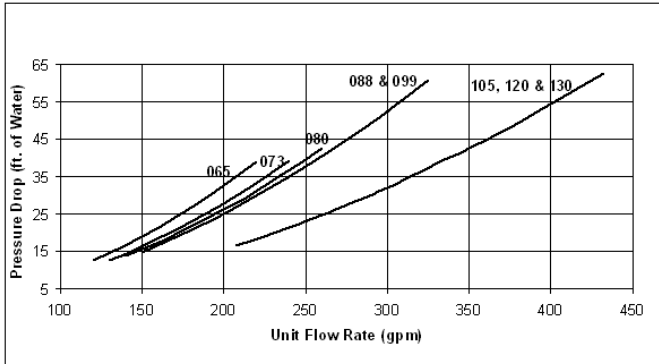
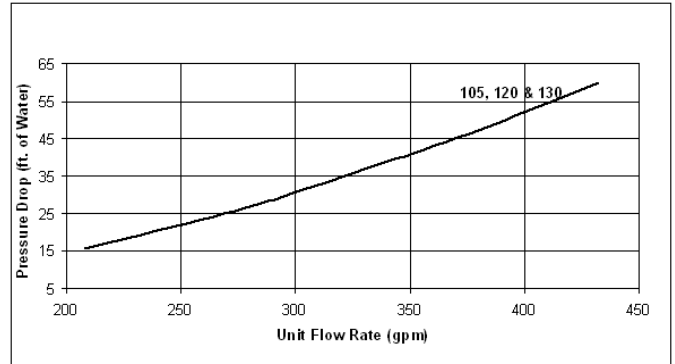

Figure 42: Large Economizer Coil



**NOTE:** Total water pressure drop varies depending on a units selected options. Only use the specific chart which reflects your unit. The above figures illustrate total water pressure drop (WPD) for each associated model number.

- Use [Figure 39](#) if no water side economizer coil or water regulating valve is provided
- Use [Figure 40](#) for standard economizer coils and [Figure 42](#) for large economizer coils
- Use [Figure 41](#) if a water regulating valve is provided

### Fan Curves

Figure 43: 13.5" Diameter, 9-Blade Fan

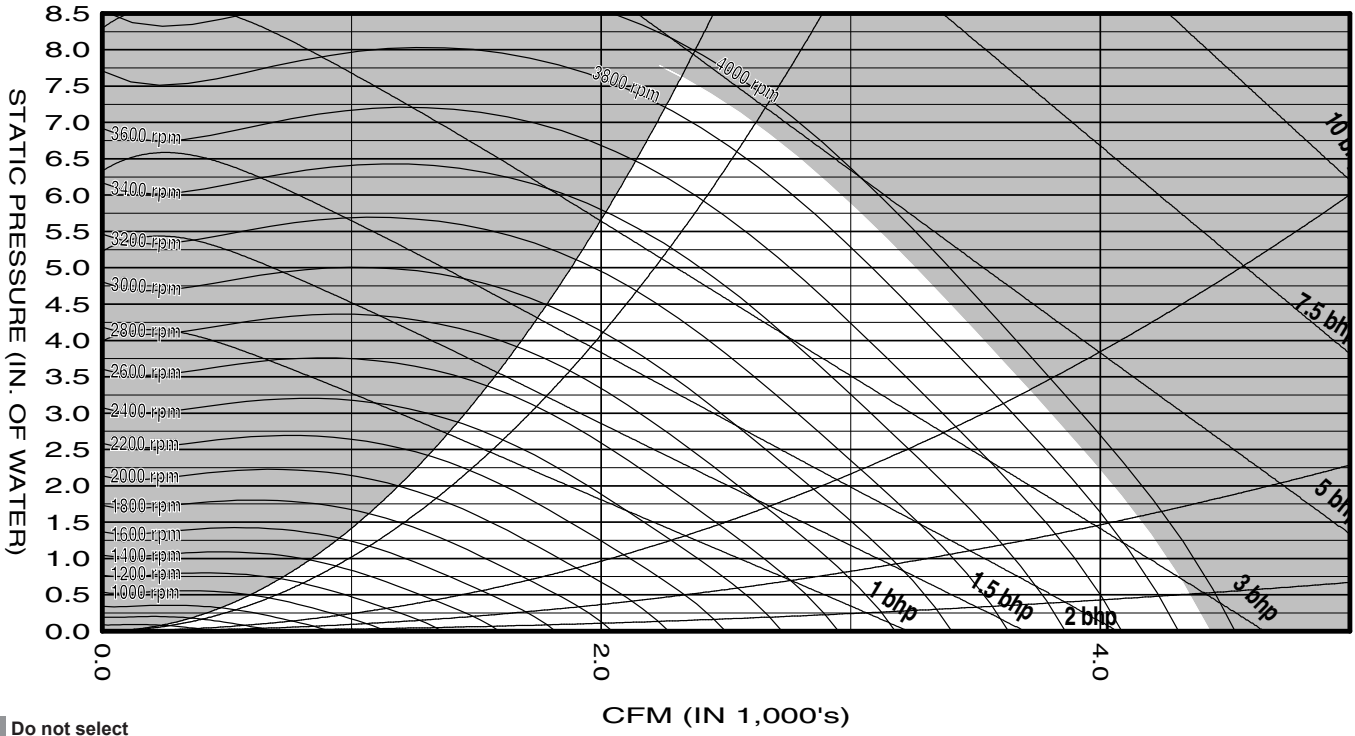

Figure 44: 15.0" Diameter, 9-Blade Fan

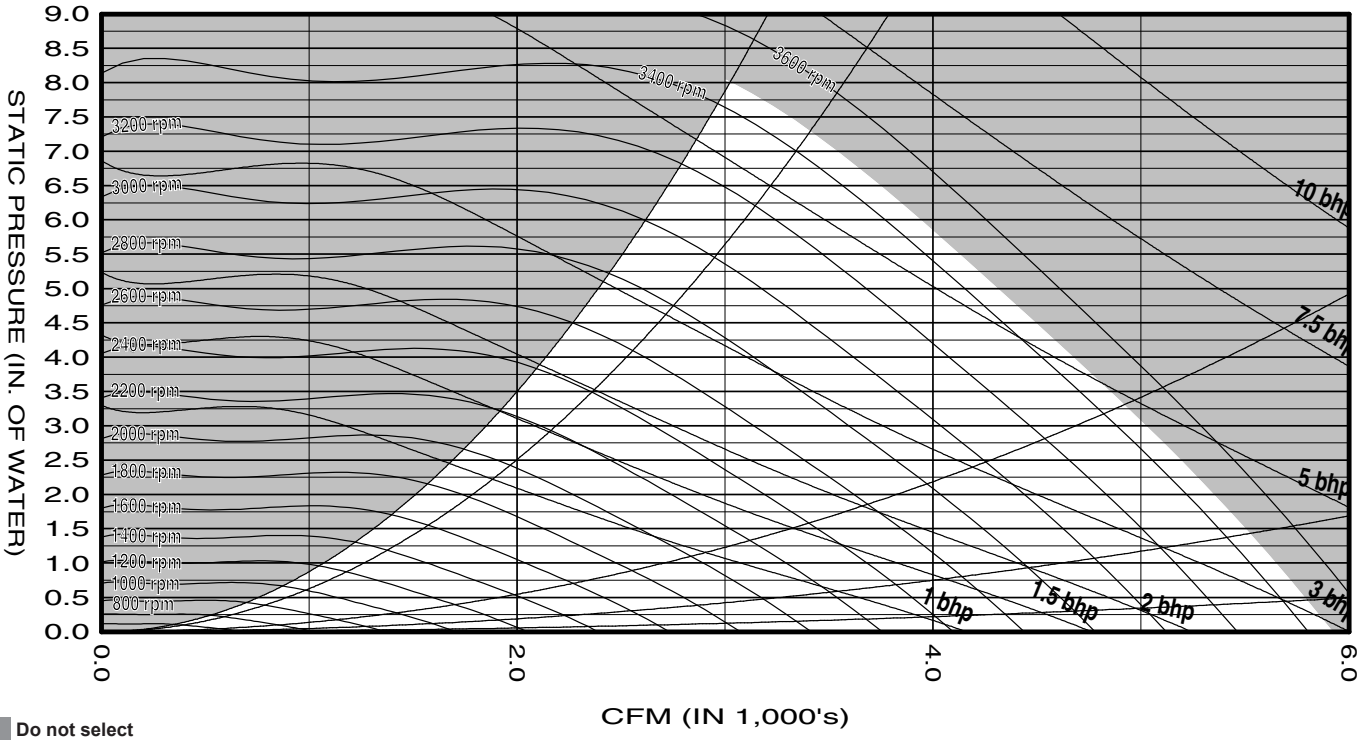

Figure 45: 16.5", 9-Blade Fan

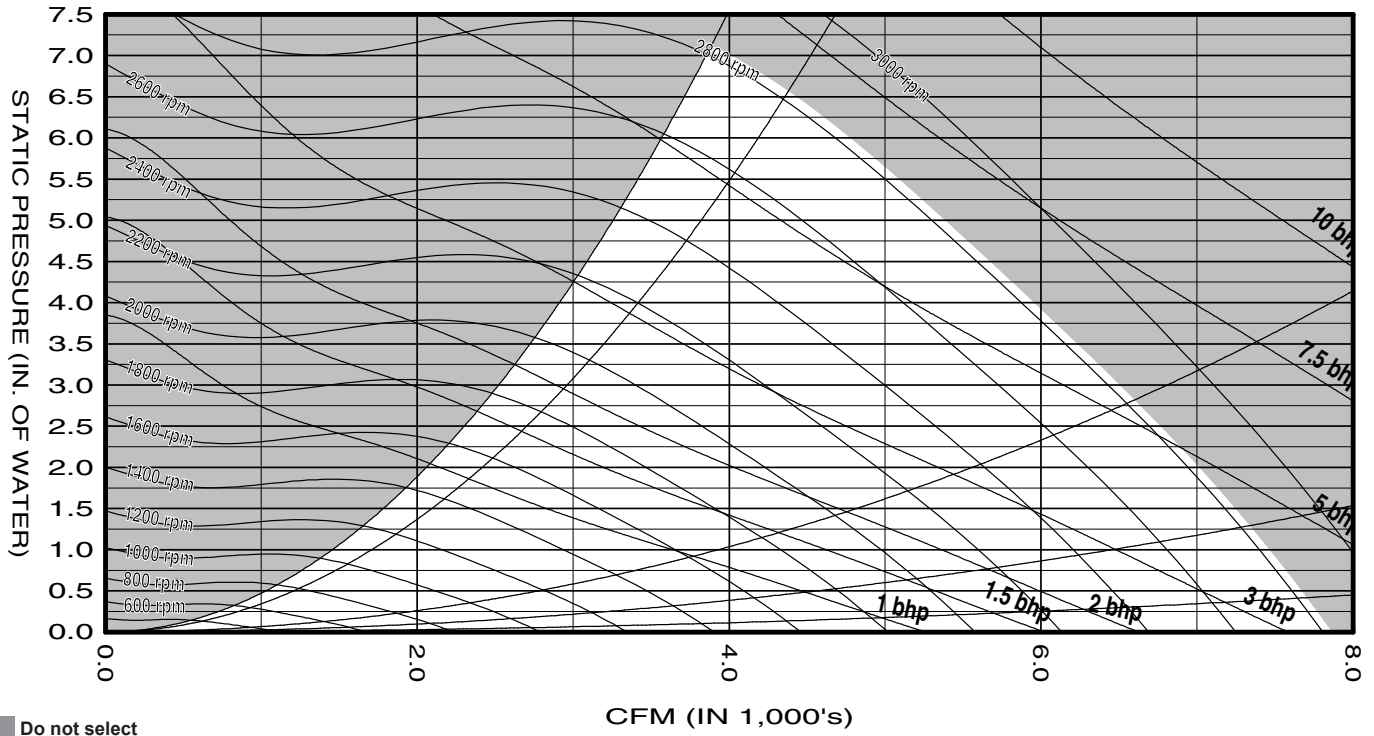

Figure 46: 18.2", 9-Blade Fan

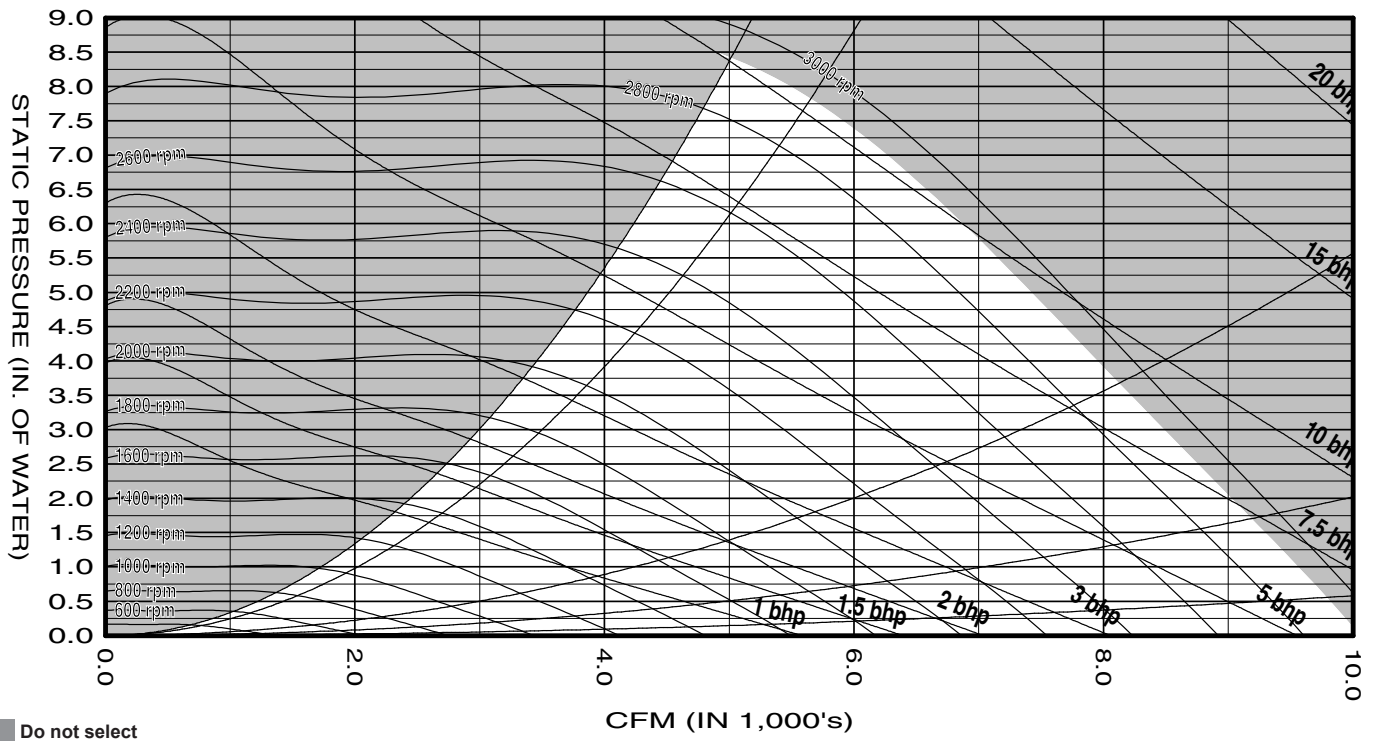



Figure 47: 20.0", 9-Blade Fan

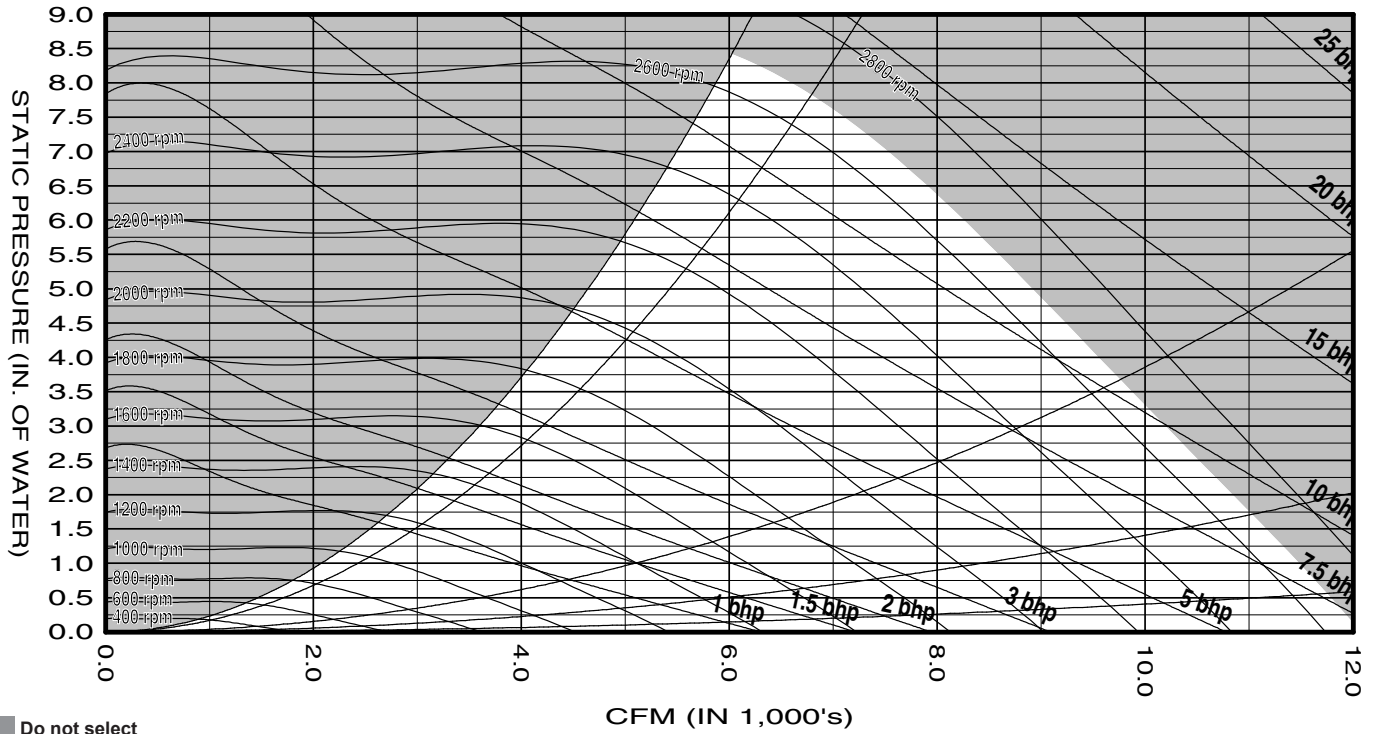

Figure 48: 22.2", 9-Blade Fan

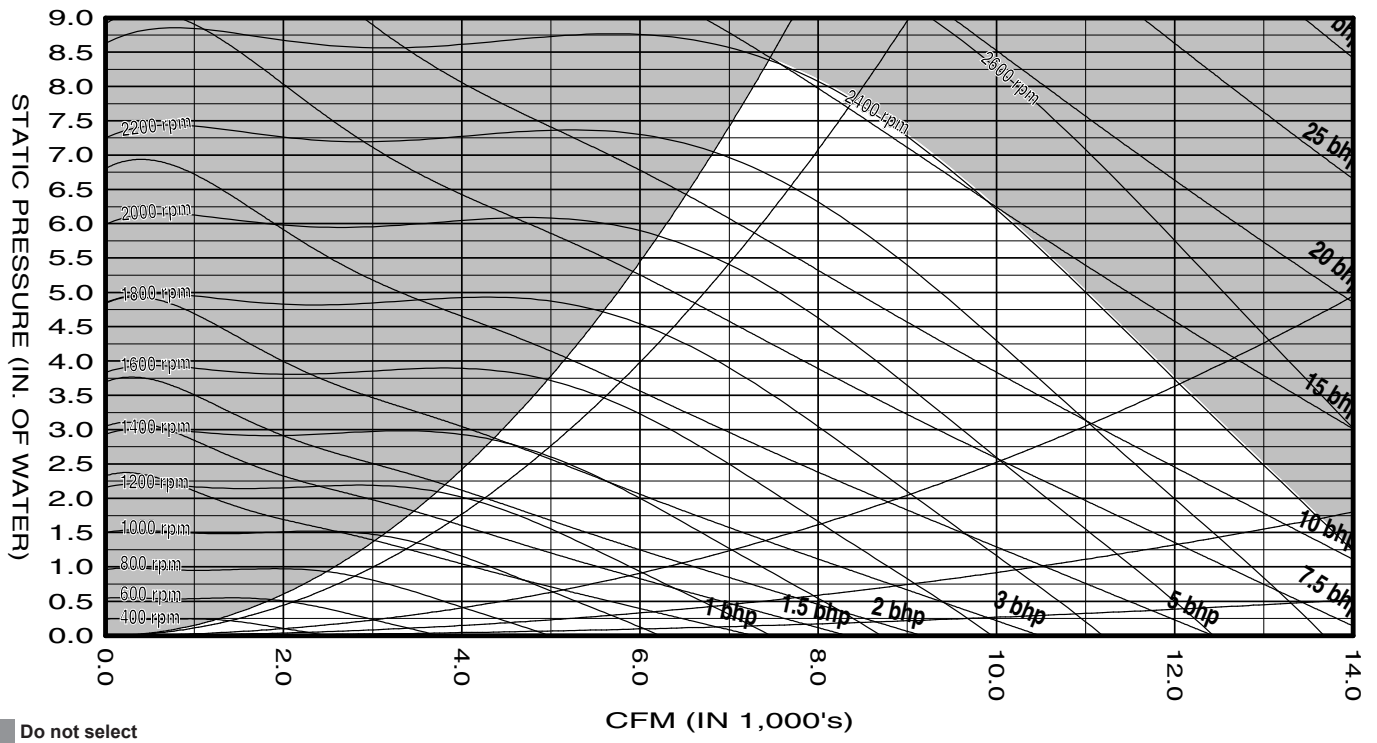

Figure 49: 24.5", 9-Blade Fan

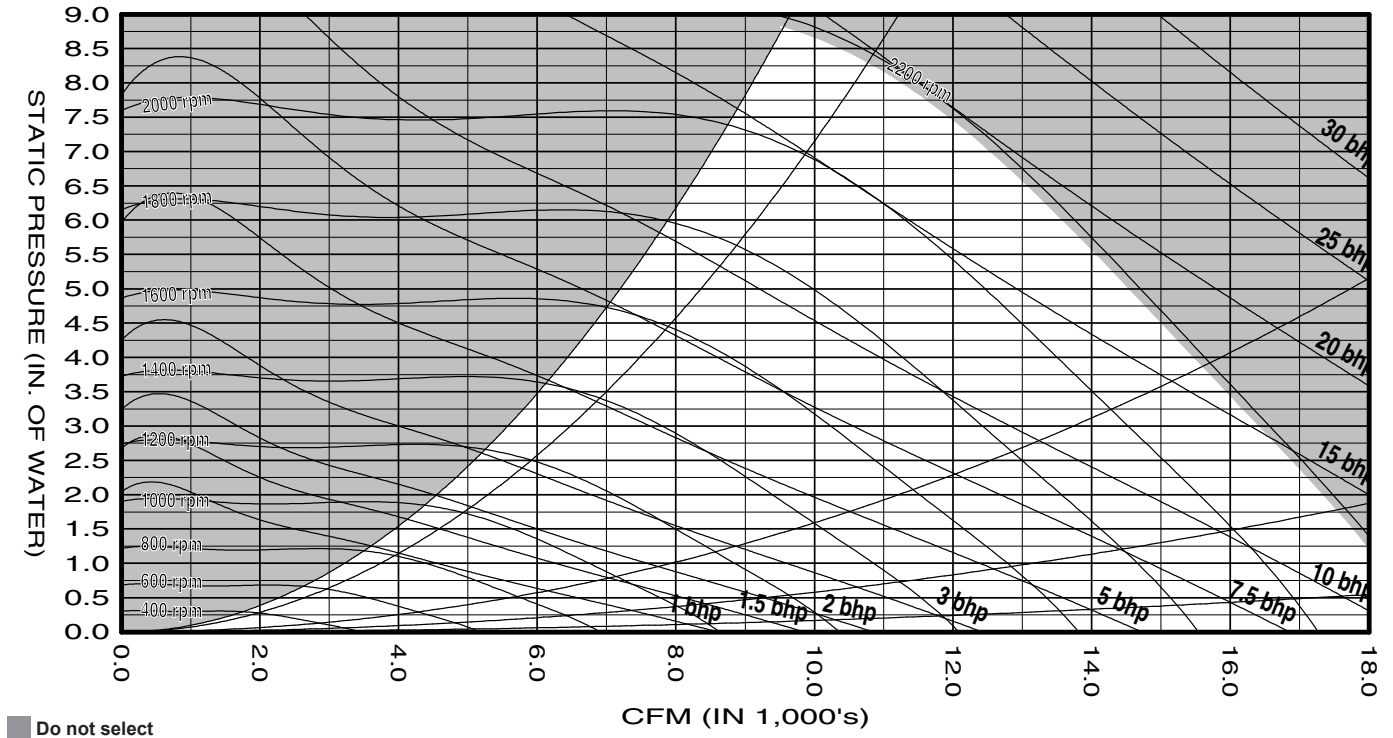

Figure 50: 27.0", 9-Blade Fan

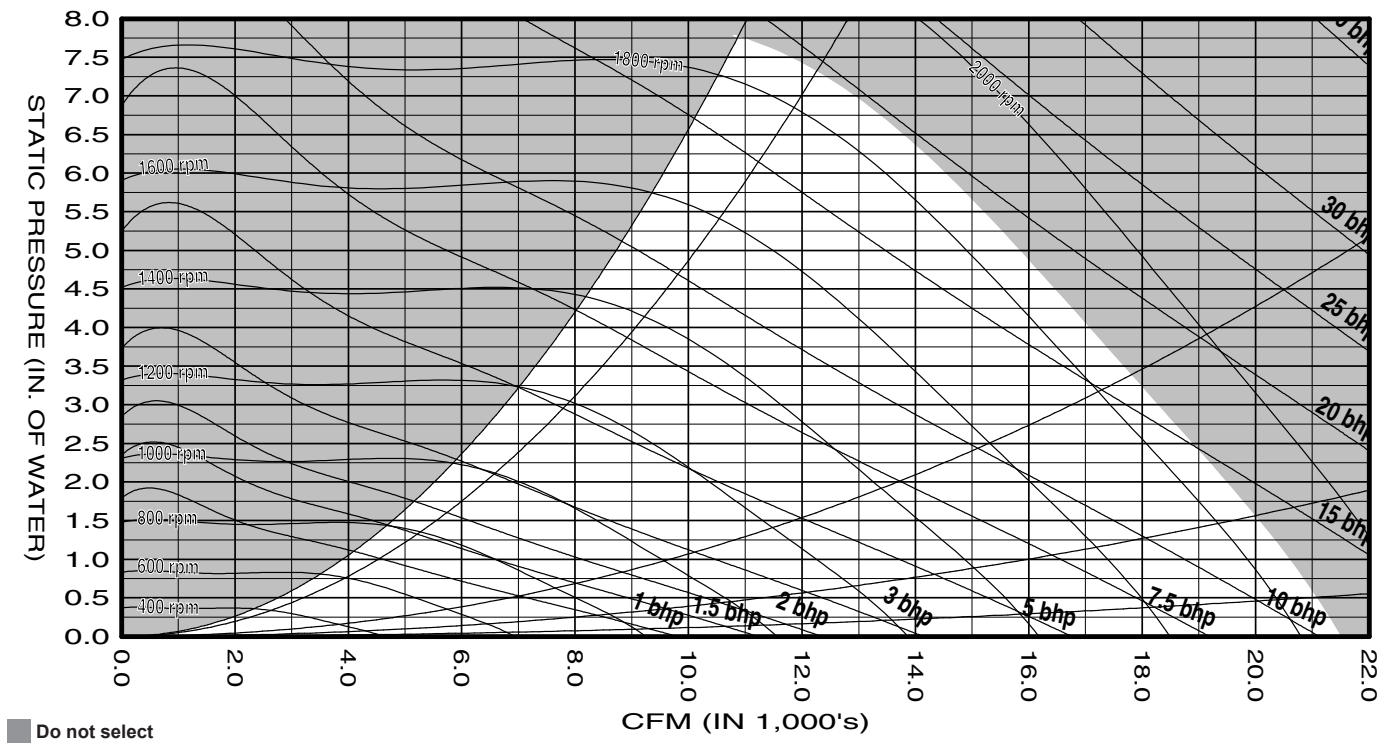

Figure 51: 30.0", 9-Blade Fan

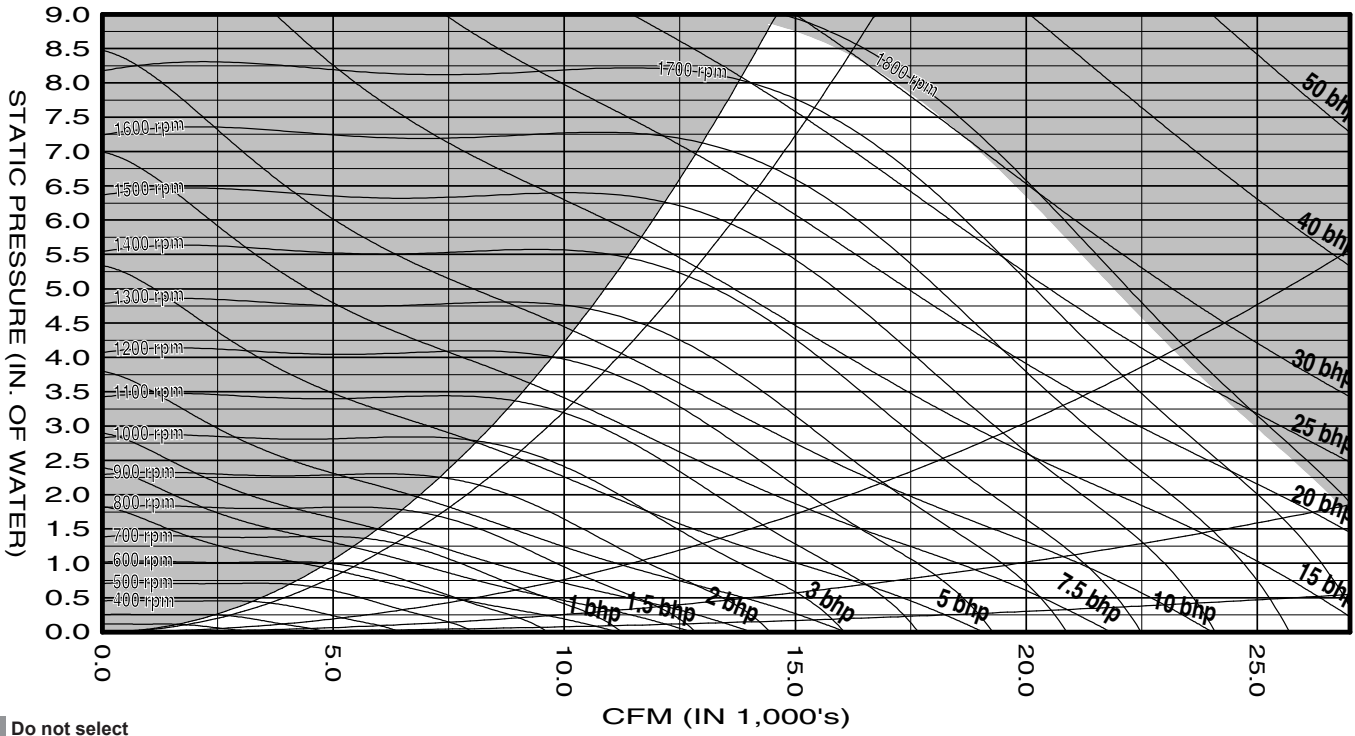

Figure 52: 33.0", 9-Blade Fan

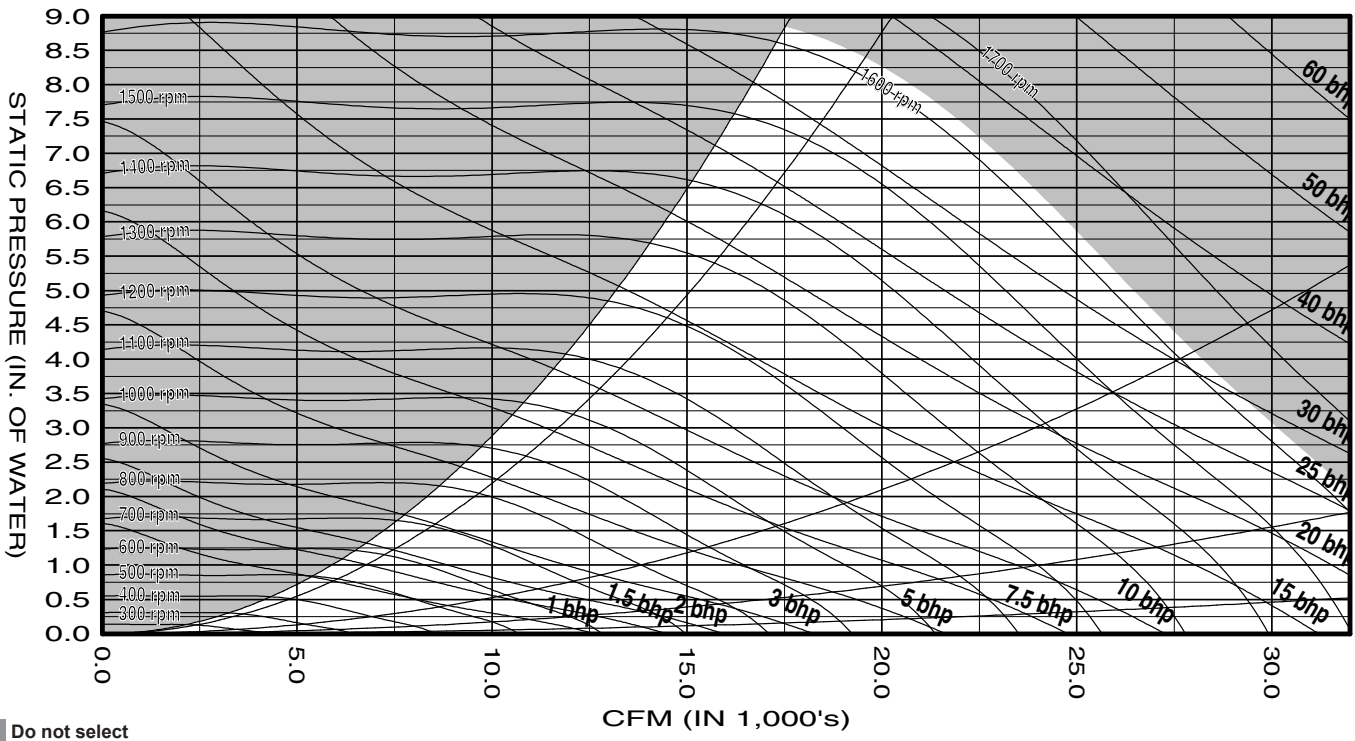

Figure 53: 36.5", 9-Blade Fan

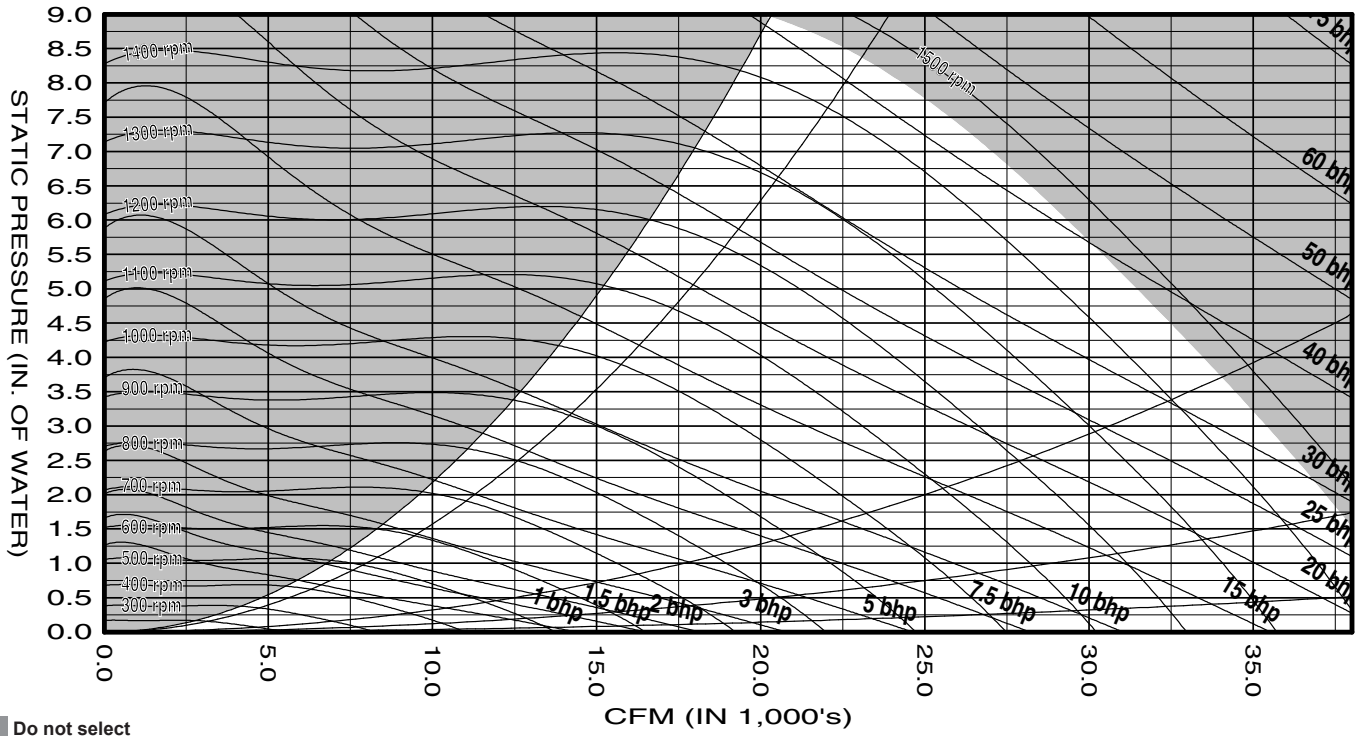

Figure 54: 40.2", 9-Blade Fan

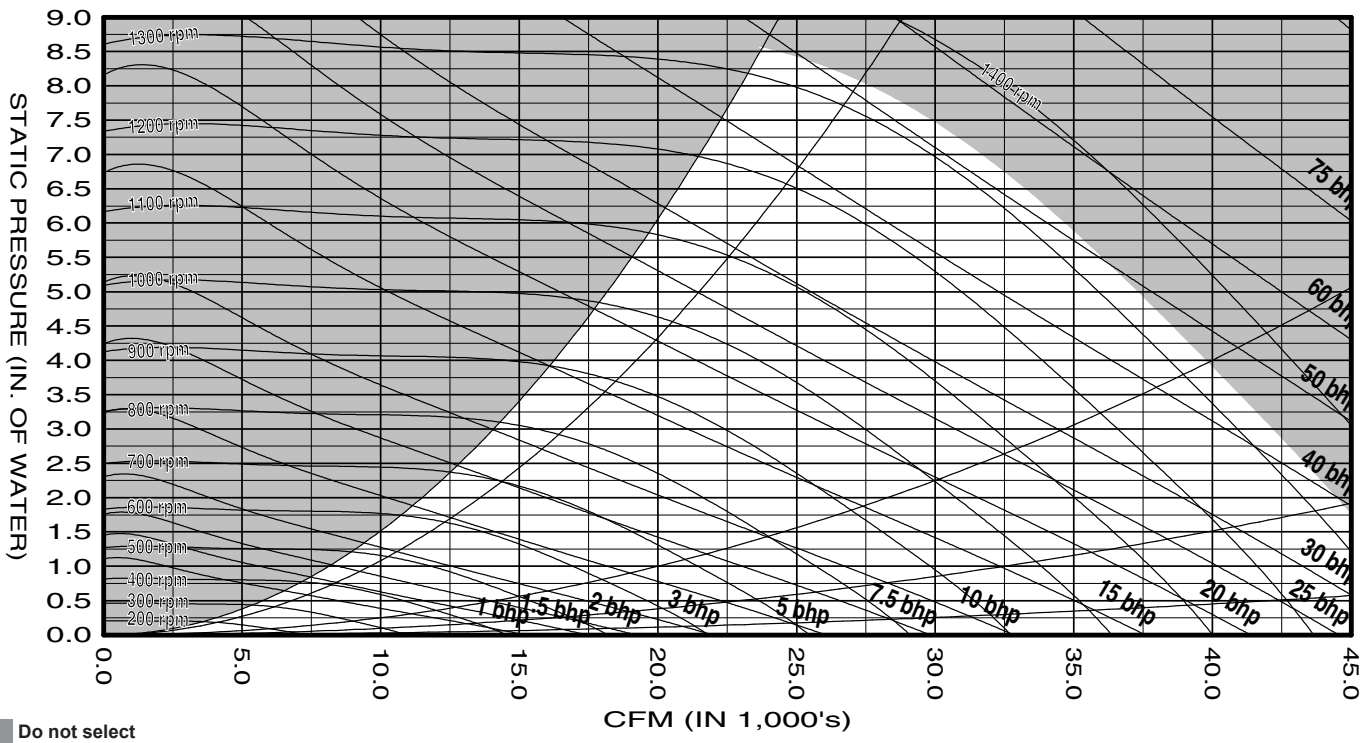
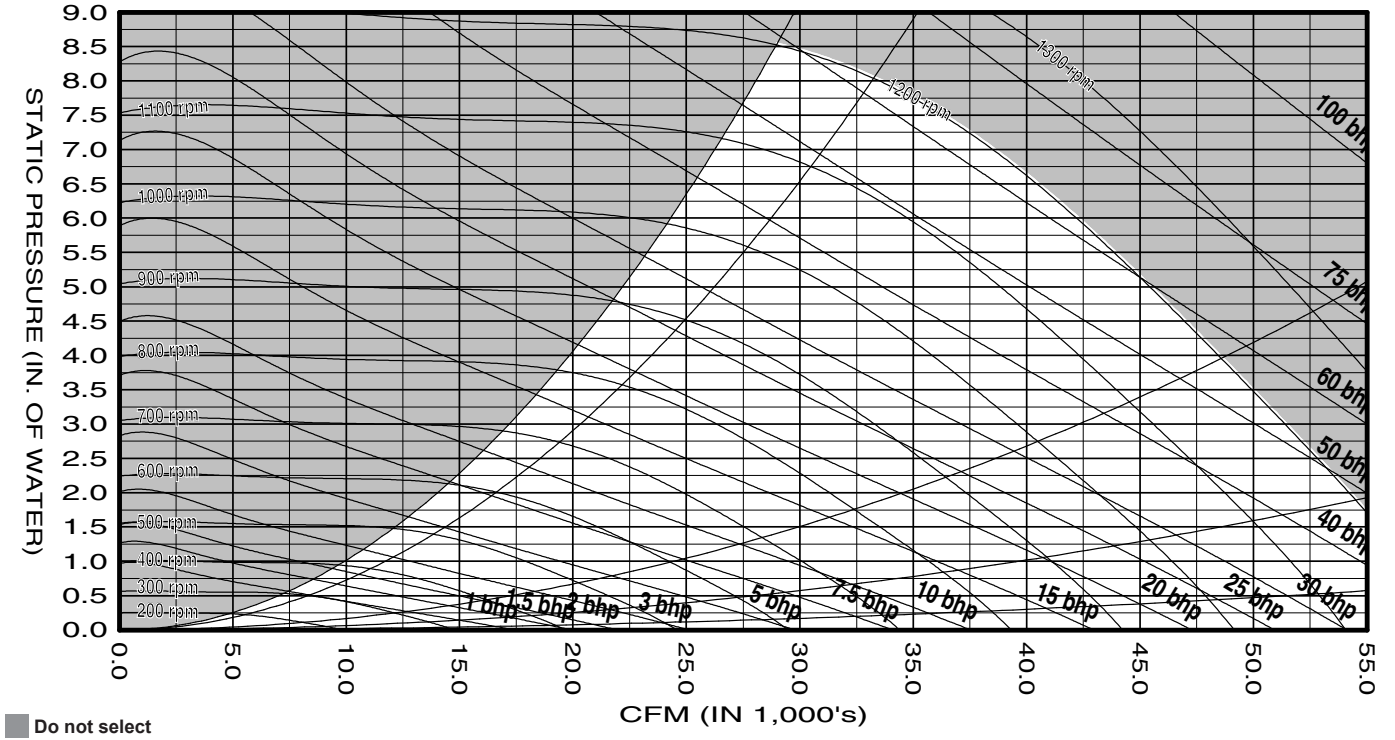

Figure 55: 44.5", 9-Blade Fan



## Recommended Clearances

For good installation, service and maintenance access, follow the recommended clearances given in this publication. Minimum clearances required by federal, state and local codes, such as the NEC, take precedence over the dimensions given. Clearance is required to allow room for side filter access, mechanical cleaning of condenser tubes, economizer coil access to expansion valves and other control components and allow for possible fan shaft or compressor removal.

**Table 27: Recommended Minimum Clearances**

Location	Clearance Length (Inches)
Front	36
Rear	24
Access Side	42
Opposite Access Side	18

**NOTE:**  
For clearance requirements less than those indicated, contact your local Daikin sales representative.

**Figure 56: Recommended Service and Maintenance Clearances**

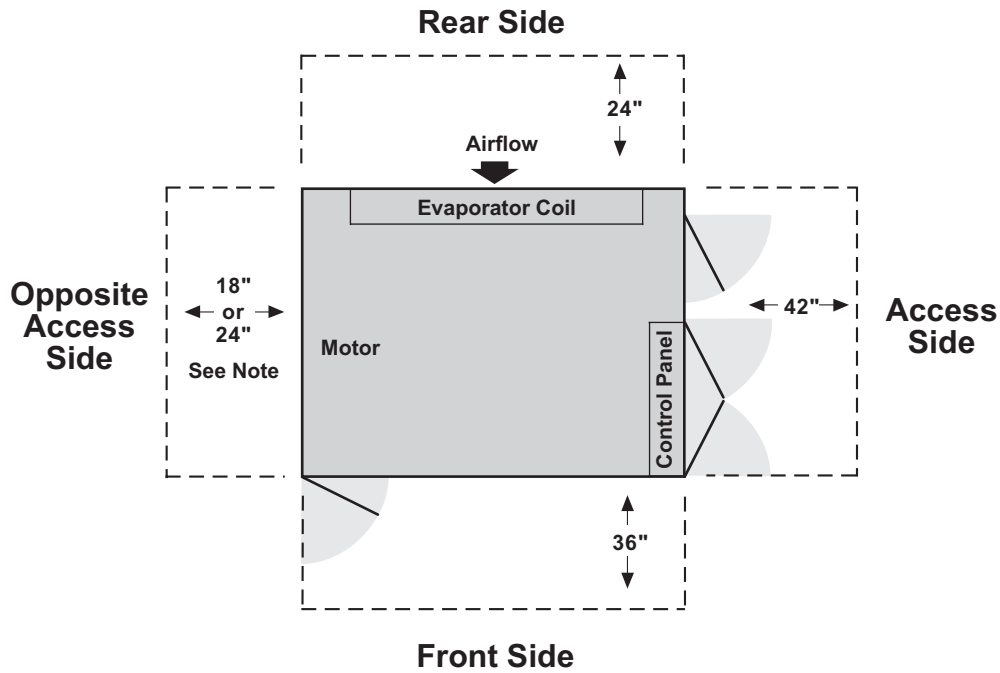

**NOTE:** If water and condenser drains are on the motor side, 24" is required.



Figure 57: Self-Contained SWP—Front View (Left Hand Access Shown/Optional Plenum)

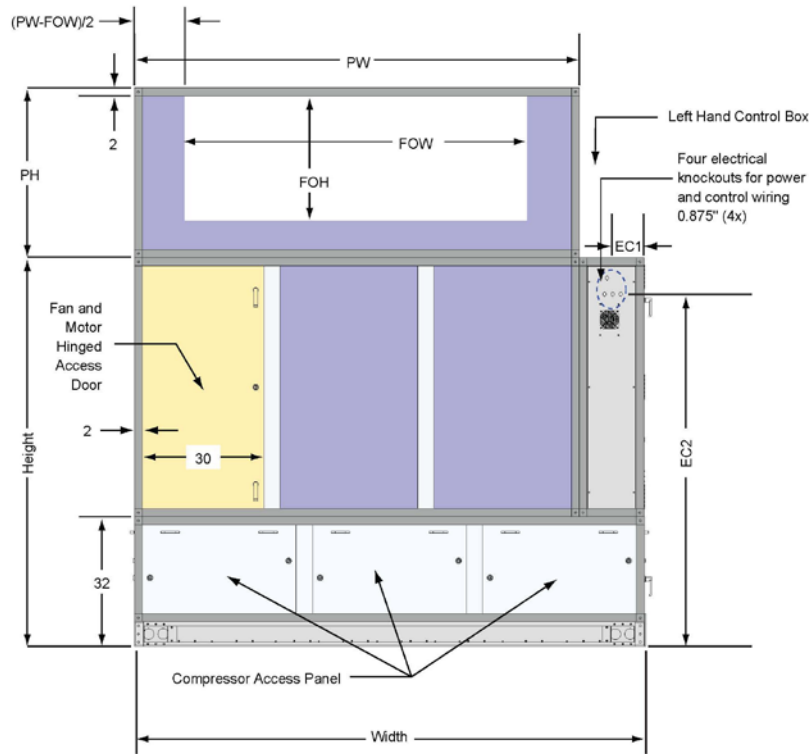

Table 28: Dimensions (Inches)

Cabinet and Unit Sizes		Small	Small Tall	Medium		Large	Large Tall	
		023-033	039-050	044-051	056-066	062-088	065-099	105-130
Total Unit	Height <sup>1, 2</sup>	80.0	84.0	96.0	96.0	96.0	112.0	112.0
	Width <sup>1, 2</sup>	84.0	84.0	102.0	102.0	126.0	126.0	126.0
	Depth <sup>1, 2</sup>	80.0	80.0	88.0	88.0	98.0	98.0	106.0
Power and Control Knockouts	EC1	5.5	5.5	7.5	7.5	7.5	7.5	7.5
	EC2	71.0	75.0	87.0	87.0	87.0	103.0	103.0
Plenum Width	PW <sup>3, 4</sup>	70.0	70.0	86.0	86.0	110.0	110.0	110.0
Plenum Depth	PD <sup>3, 4</sup>	44.0	44.0	48.0	48.0	58.0	58.0	66.0
Condenser Water Connections (ODS)	WC1	23.0	23.0	25.0	25.0	27.0	27.0	27.0
	WC3	74.0	78.0	90.0	90.0	90.0	106.0	106.0
	DIA1	2.125	2.625	2.625	3.125	3.125	3.125	4.125
	DIA2	2.125	2.625	2.625	3.125	3.125	3.125	4.125
Drain Connections (MPT)	DC1	18.0	18.0	20.0	20.0	20.0	20.0	20.0
	DC2	7.0	7.0	7.0	7.0	9.0	9.0	9.0
Fan Discharge Opening	DOD	32.0	32.0	32.0	32.0	32.0	40.0	40.0
	DOL	10.0	10.0	10.0	10.0	10.0	10.0	10.0
	DOW	52.0	52.0	68.0	68.0	92.0	92.0	92.0
Fan and Compressor Section Depth	SD1	44.0	44.0	48.0	48.0	58.0	58.0	66.0
Coil Section Depth	SD2	36.0	36.0	40.0	40.0	40.0	40.0	40.0
Control Panel Width	SW1	14.0	14.0	16.0	16.0	16.0	16.0	16.0

NOTE:

- Dimensions do not include lifting lugs, handles, latches or fastener extensions.
- For shipping dimensions, add 4" to the depth, 8" to the length and 4" to the height.
- Plenum height is user configurable.
- Plenum opening height and width requires a minimum of 2" clearance on each side.

Figure 58: Self-Contained SWP Left Side View (Left Hand Access Shown with Piping and Optional Discharge Plenum)

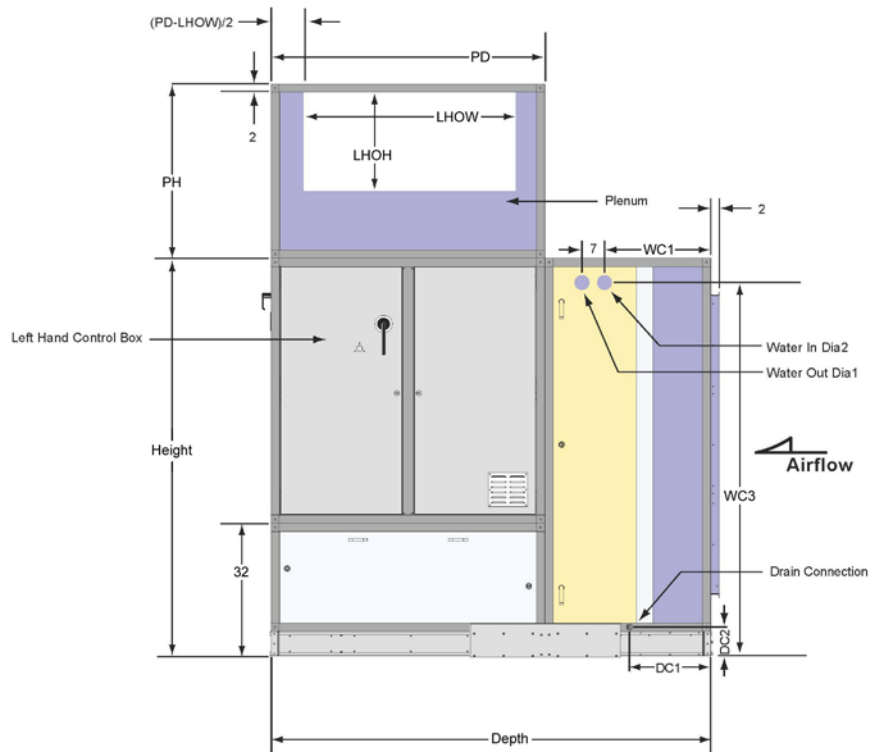

Figure 59: Self-Contained Top View (Left Hand Access Shown/without Discharge Plenum)

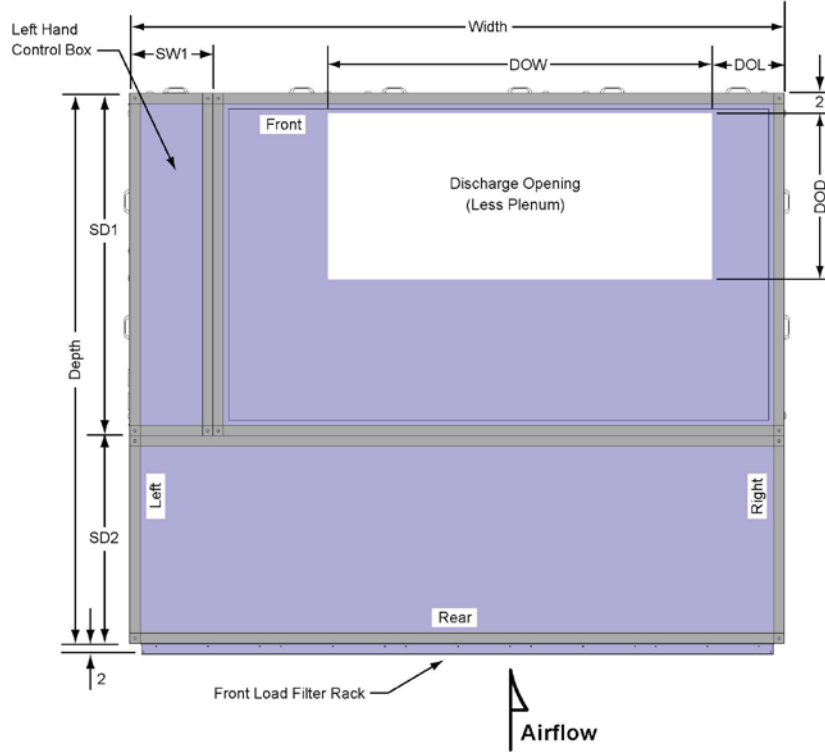

Figure 60: SWP Discharge Plenum Dimensions

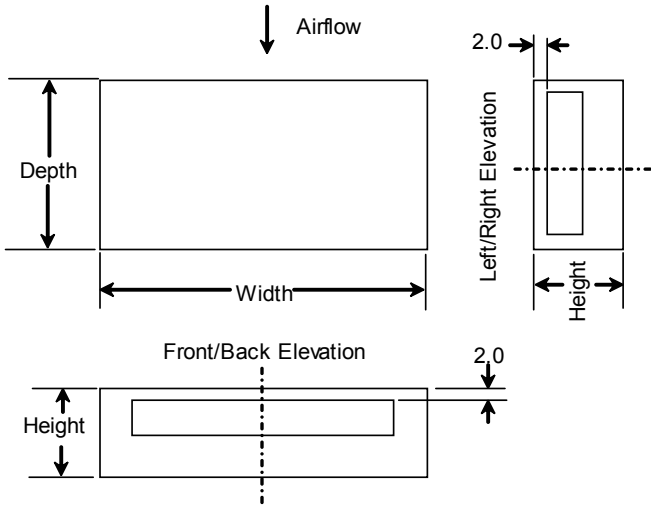

Table 29: Fan Section Dimensions

Cabinet Size	Width (in.)	Depth (in.)
Small	70	44
Small Tall	70	44
Medium	86	48
Large	110	58
Large Tall	110	66

Table 30: Discharge Plenum Heights

Cabinet Size	Available Factory-mounted <sup>1</sup> Discharge Plenum Heights (in.)								
	Small	20	24	28	32	36	40	—	—
Small Tall	20	24	28	32	36	—	—	—	—
Medium	20	24	—	—	—	—	—	—	—
Large	20	24	—	—	—	—	—	—	—
Large Tall	—	—	—	—	—	—	—	—	—
Available Field-mounted <sup>2</sup> Discharge Plenum Heights (Inches)									
Small	20	24	28	32	36	40	44	48	—
Small Tall	20	24	28	32	36	40	44	48	—
Medium	20	24	28	32	36	40	44	48	—
Large	20	24	28	32	36	40	44	48	—
Large Tall	20	24	28	32	36	40	44	48	—

**NOTE:**

1. Maximum shipping height is 120" with a step-deck trailer.
2. Total minimum opening size (sq.ft., (H×L)/144) needs to be greater than or equal to CFM/maximum FPM, maximum FPM = 2500.

**Table 31: Duct Opening Heights**

Plenum Height	Available Duct Openings Heights (in.)								
20	16	—	—	—	—	—	—	—	—
24	16	20	—	—	—	—	—	—	—
28	16	20	24	—	—	—	—	—	—
32	16	20	24	28	—	—	—	—	—
36	16	20	24	28	32	—	—	—	—
40	16	20	24	28	32	36	—	—	—
44	16	20	24	28	32	36	40	—	—
48	16	20	24	28	32	36	40	44	—

**Table 32: Left/Right Duct Opening Lengths**

Cabinet Size	Left/Right Duct Opening Lengths (in.)							
Small	20	24	28	32	36*	40	—	—
Small Tall	20	24	28	32	36*	40	—	—
Medium	20	24	28	32	36	40*	44	—
Large	20	26	34	42	50*	54	—	—
Large Tall	20	26	34	42	50	54*	62	—

**NOTE:**

\*If an opening is 8" narrower than the overall cabinet Depth, the opening will be offset 2" from center.

**Table 33: Front/Back Duct Opening Lengths**

Cabinet Size	Front/Back Duct Opening Lengths (in.)											
Small	18	26	34	42	50	58	66	—	—	—	—	—
Small Tall	18	26	34	42	50	58	66	—	—	—	—	—
Medium	18	26	34	42	50	58	66	74	82	—	—	—
Large	18	26	34	42	50	58	66	74	82	90	98	106
Large Tall	18	26	34	42	50	58	66	74	82	90	98	106

### Supply Power Wiring

1. Units require three-phase power supply.
2. Allowable voltage tolerances:
  - a. 60 Hertz
    - Nameplate 208V: Min. 187V, Max. 229V
    - Nameplate 230V: Min. 207V, Max. 253V
    - Nameplate 460V: Min. 414V, Max. 506V
    - Nameplate 575V: Min. 518V, Max. 632V
  - b. 50 Hertz
    - Nameplate 400V: Min. 342V, Max. 418V
3. Power lead wire sizing:
  - a. For units with cooling capability (all concurrent loads) with or without hot water heating and circuits with motor loads only:
 
$$MCA = 1.25 \text{ (largest motor RLA or FLA) + other loads}$$
4. Size wires in accordance with Table 310-16 or Table 310-19 of the [National Electrical Code](#).
5. Size wires for a maximum of 3% voltage drop.

**Table 34: SAF Motor Nameplate Amperage**

Horsepower	Type	208/60/3	230/60/3	400/50/31	460/60/3	575/60/3
		FLA	FLA	FLA	FLA	FLA
3	Premium efficiency	9.3	8.2	4.1	4.1	3.1
5	Premium efficiency	15.7	13.6	6.8	6.8	5.2
7.5	Premium efficiency	22.3	20.0	10.0	10.0	7.4
10	Premium efficiency	29.0	25.8	12.9	12.9	10.3
15	Premium efficiency	43.4	37.8	18.9	18.9	14.1
20	Premium efficiency	57.0	49.0	24.5	24.5	18.9
25	Premium efficiency	70.0	61.0	30.5	30.5	24.2
30	Premium efficiency	83.3	72.4	36.2	36.2	29.8
40	Premium efficiency	110.0	96.0	48.0	48.0	38.0
50	Premium efficiency	137.0	120.0	60.0	60.0	47.5
60	Premium efficiency	160.0	140.0	70.0	70.0	56.0

**Table 35: Compressor Motor Amperage**

Compressor HP	Refrigerant	208/60/3		230/60/3		460/60/3		575/60/3	
		RLA	LRA	RLA	LRA	RLA	LRA	RLA	LRA
6	R-410A	21.0	182	19.0	164	8.4	75.0	6.8	54
7	R-410A	20.2	182	19.6	164	11.6	100	9.8	78
8	R-410A	23.2	216	22.5	195	11.3	95.0	9.0	80
9	R-410A	26.9	249	25.0	225	12.6	114.0	9.6	80
10	R-410A	30.3	264	28.2	239	14.2	125.0	10.6	80
11	R-410A	35.4	271	32.0	245	15.5	125	12.6	100
13	R-410A	40.8	332	38.5	300	18.3	150.0	17.4	109
15	R-410A	49.8	376	48.4	340	18.5	173.0	20.2	132

### Lug Sizing

**Table 36: Lug sizes for single disconnect**

Disconnect size	(Qty) Lug size
100	#12-3/0
150	#12-3/0
250	#8-350 MCM
400	(2) #8-600 MCM
600	(2) #8-600 MCM

**Table 37: Lug sizes for power block**

Power block size	(Qty) Lug size
310	#6-350 MCM
420	#2-600 MCM
570	(2) #4-300 MCM

**NOTE:**  
Use copper wire only. 760 (2) #6-500 MCM

## PART 1: GENERAL

### 1.01 GENERAL

- A. Conform to the General Provisions for Mechanical Section, Controls Section, and Basic Materials and Methods Section.

### 1.02 ACCEPTABLE MANUFACTURERS

- A. Qualified manufacturers must be able to demonstrate a minimum of five years' experience with the specified product application.

### 1.03 SUBMITTALS

- A. Shop Drawings: Submit cooling/heating capacities, fan performance, sound generation details, air and water pressure drops, filter efficiency, gauges and finishes of materials, assembly details, unit dimensions, weight, required clearances, construction details, field connection details, electrical characteristics, wiring diagrams and electrical connection requirements. Submittal information must include compressor kW requirements, at design conditions, to allow for a system energy analysis.
- B. Product Data: Complete product specifications.

## PART 2: PRODUCTS

### 2.01 GENERAL

- A. Furnish and install Daikin Applied Model SWP self-contained water-cooled compartment units.
- B. All units must be ETL and ETL-Canada listed by Intertek Testing Services, Inc. Units shall conform to bi-national standard ANSI/UL Standard 1995/CSA Standard C22.2 No. 236.
- C. As a minimum, all units shall comply with ASHRAE Standard 90.1-2013 unit efficiency and fan brake horsepower requirements.
- D. Models, performance, electrical ratings, and unit arrangement shall be as shown on the unit schedule and the contract drawings.
- E. Provide each unit factory assembled, piped, wired, tested and shipped in one piece. [Modular units shall be leak tested and shipped with nitrogen holding charge and POE refrigerant oil.] Installation, maintenance and operation bulletins, wiring diagrams and start-up forms shall be supplied with each unit
- F. Manufacturers shall ensure that their product fits within the MER with allowance for sufficient clearance to satisfy local, state or national codes, such as the NEC, as well as for access to all serviceable components

- G. Manufacturers shall ensure that their product's field piping location matches the riser locations designated on the contract drawings. If the manufacturer cannot provide matching piping locations, the contractor shall be responsible for any additional field piping required.
- H. Each unit shall undergo a rigorous function test prior to shipment. The function test shall include dynamic trim balancing of the completed fan assembly, a complete run test of all electrical components and safeties, including proper control sequencing, a leak check of all refrigerant circuits, a leak check of all water circuits and a final unit inspection.

### 2.02 CABINET

- A. Fabricate unit with 16 gauge channel posts and panels secure with mechanical fasteners. All panels and access doors shall be sealed with permanently applied bulb-type gasket.
  1. Panels and access doors shall be constructed as a 2-inch (50-mm) nominal thick; thermal broke double wall assembly, with 2-inch foam.
  2. The outer panel shall be constructed of G60 unpainted galvanized steel
  3. All sections will have internal lining, constructed of G90 galvanized steel.
  4. The unit cabinet base shall be constructed of unpainted galvanized steel.
- B. Access doors shall be flush mounted to cabinetry, with hinges, latch and handle assembly. Door shall swing outward for unit sections under negative pressure. Doors limited from swinging inward on positive pressure sections shall have a secondary latch to relieve pressure and prevent injury upon access.
- C. Construct drain pans from G90 galvanized steel welded with cross break and double sloping pitch to drain connection. Provide drain pans in cooling coil section. There must be a full 2" thickness of insulation under drain pan.
- D. Each unit will be comprised of three distinct sections: 1) Supply Fan/Control Panel, 2) Condenser/Compressor 3) Waterside Economizer/Evaporator Coil. Each unit shall be designed for disassembly into the three distinct sections for access to the mechanical equipment room. Separation of water piping shall be through the use of factory installed grooved couplings.



### 2.03 EVAPORATOR COIL

- A. The direct expansion coil shall be a minimum of 5-rows for good humidity control. Coils shall be constructed of ½ inch OD, 0.016 inch nominal tube wall thickness, high efficiency, seamless copper tubing mechanically bonded to high efficiency aluminum plate fins. The coil casing shall be constructed of G90 galvanized. All distributor tubes shall be covered with plastic sheathing to eliminate refrigerant loss due to damage done by vibration over the life of the equipment.
- B. All units shall have an independent refrigeration circuit per compressor and shall use a combination of row and interlaced circuiting for efficient part load operation while preventing air temperature stratification at part load.
- C. For good part load performance, stages of capacity unloading shall be not less than that shown on the equipment schedule.

### 2.04 SUPPLY AIR FAN

- A. Provide belt-drive airfoil plenum type fan. Fan assemblies including fan, motor and sheaves shall be dynamically balanced by the manufacturer on all three planes and at all bearing supports. Manufacturer must ensure maximum fan RPM is below the first critical speed.
- B. Bearings shall be self-aligning, grease lubricated, ball or roller bearings.
- C. Fan and motor shall be mounted internally on a steel base. Provide access to motor, drive, and bearings through hinged access door. Fan and motor assembly shall be mounted on 2" deflection spring vibration type isolators inside cabinetry. [Seismic snubbers shall be provided.]
- D. Basic load rating computed in accordance with AFBMA - ANSI Standards, L-50 life at 200,000 hours all belt-drive airfoil plenum fans, heavy duty pillow block type, self-aligning, grease-lubricated ball bearings.
- E. Shafts shall be solid, hot rolled steel, ground and polished, keyed to shaft, and protectively coated with lubricating oil.
- F. V-Belt drives shall be cast iron or steel sheaves, dynamically balanced, bored to fit shafts and keyed. Fixed sheaves, matched belts, and drive rated based on motor horsepower. Minimum of 2 belts shall be provided on all fans with 10 HP motors and above. Standard drive service factor shall be 1.1 S.F. for 10HP and larger, calculated based on fan brake horsepower.

### 2.05 VARIABLE AIR VOLUME

- A. Airflow modulation shall be achieved by the use of a factory installed variable frequency drive. Unit temperature control system shall control the drive through a Modbus communication interface. The drive shall be factory installed in a designated location, behind a hinged access door that provides ready access to the drive and does not void unit accessibility. Drive status and operating speed shall be monitored and displayed at the main unit control panel. Drives shall meet UL Standard 95-5V and the manufacturer shall have specifically approved them for plenum duty application. The completed unit shall be listed by a recognized safety agency, such as ETL. All drives shall be factory run tested prior to shipment.
- B. [A manual bypass shall be provided such that the fan can be run at full speed if the VFD is not operational.]
- C. Static pressure shall be controlled by the factory installed main unit control system, with the static pressure set point adjustable at the unit microprocessor. Static pressure shall be sensed by [one] [two] unit mounted duct static pressure sensor. The installer shall provide and install sensor tubing from the unit to the sensing location.
- D. A factory installed, field adjustable duct high-limit control shall be provided to protect ductwork from possible excessive duct pressure.

### 2.06 REFRIGERATION CIRCUIT

- A. Each unit shall have multiple independent refrigeration circuits. Each circuit shall include heavy duty compressor, filter-drier, liquid moisture indicator/sight-glass, thermal expansion valve, liquid line shutoff valve with charging port and a re-seating type high pressure relief device. The thermal expansion valve shall be capable of modulation from 100% to 25% of its rated capacity. Each circuit shall be dehydrated and factory charged with nitrogen and POE oil. Each refrigerant circuit shall have a manual reset high-pressure cutout switch and a low-pressure cutout switch. Each low pressure control (loss of charge) shall require a manual reset if the alarm condition occurs three times within any 24 hour period.
- B. Each circuit shall include high and low pressure gauge connections as well as liquid, discharge [and suction] service valves with gauge ports.

## 2.07 COMPRESSOR

- A. Each unit shall have multiple heavy-duty scroll compressors with sight-glass, anti-slug protection, motor overload protection and a time delay to prevent short cycling and simultaneous starting of compressors following a power failure. Compressors shall be isolated on resilient rubber isolators to decrease noise transmission. The number of compressors shall be as shown on the unit schedule.
- B. Capacity of each compressor shall not be greater than 15 horsepower.
- C. Compressors shall have discharge [and suction] line service valves, with gauge port, to aid in system service over the equipment life.
- D. Unit temperature control system shall include provision for automatic lead/lag compressor starts.

## 2.08 CONDENSER

- A. Condensers shall be counter flow; shell and tube design with non-ferrous water channels suitable for scheduled waterside working pressure, and shall be mechanically cleanable.
- B. Condensers shall be factory manifolded so the installer must only provide single supply and return tower water connections for low cost field hook up. All factory piping shall be capable of [180] [450] psig waterside working pressure and the completed condenser and piping assembly shall be factory leak tested.
- C. Each compressor shall be on an independent refrigerant circuit. Condensers shall provide liquid sub-cooling for optimum system performance.
- D. All condensers must be mechanically cleanable to promote ease of cleaning for consistent long term performance. Access for tube brushing shall be through gasketed removable heads.

## 2.09 FILTERS

- A. The unit shall include a front load filter rack with frames and clips. [MERV 8 filters shall be provided.]
- B. Filter media shall be UL 900 listed, Class I or Class II.
- C. [Cartridge type arrangement with holding frames suitable for 4" (100 mm) filter media and blank-off sheets, extended surface cartridge media filters with 30% MERV 8 filter media.]

## 2.10 WATERSIDE ECONOMIZER

- A. A complete waterside economizer package, including coil, spring-return control valves and interconnecting piping shall be factory installed within the main unit casing. Access panels shall provide convenient access to the coil, valves and drain-pan for inspection and cleaning. Economizer piping shall be factory connected to the condensers for a single field supply and return connection. Coils shall be all non-ferrous construction. To allow for simultaneous economizer and mechanical cooling operation the coil shall be mounted upstream of the evaporator coil and piped for series flow with the condensers. Arrangements that do not allow simultaneous operation will not be accepted.
- B. Submitted unit water pressure drop must be calculated for series water flow and include the coil, condensers, piping and control valves.
- C. The coil shall be constructed of high efficiency; aluminum plate fins mechanically bonded to 1/2-inch OD copper tubes with a 0.035 inch nominal tube wall thickness. Coils shall be a minimum 4-row, staggered tube design. The coil casing shall be constructed of 201 stainless steel. Coil will be set in the welded drain pan as the evaporator.
- D. The coil shall be mechanically cleanable to promote ease of cleaning for consistent long-term performance. Access for tube brushing shall be through individual brass plugs using o-ring seals and brass receptacles. Units submitted with coils that are not mechanically cleanable will not be accepted.
- E. Factory installed controls shall consist of dual, 2-way modulating valves controlled by the main unit control system. Multiple control schemes shall be available to allow operation in either constant or variable flow condenser loops. To maximize energy savings, economizer operation shall be enabled whenever the entering water temperature is less than the entering air temperature by a field adjustable value. If the economizer control valve is driven 95% open and the cooling load is not satisfied, mechanical cooling will stage on to maintain desired set point. To maximize energy savings economizer control will maintain full water flow through the economizer coil until the differential between entering water and entering air temperatures falls below set point.
- F. [A factory installed, non-averaging type freeze stat shall be factory installed to provide protection against coil freeze-up.]
- G. The complete economizer assembly shall be factory leak tested.

## 2.11 ELECTRICAL

- A. Unit wiring shall comply with NEC requirements and with all applicable UL standards. All electrical components shall be UL recognized, where applicable. To provide for easy identification, all wiring and electrical components shall be numbered, color-coded and labeled according to the electrical diagrams provided with each unit. The main unit control panel shall be completely factory wired and contained in an accessible enclosure.
  - B. All motor branch circuits shall be individually circuit breaker protected and shall have thermal overload protection.
  - C. Each compressor motor circuit shall include a dedicated contactor, manual motor protector, and temperature-sensing overload. The supply fan motor circuit shall include a dedicated contactor and manual motor protector. Each refrigerant circuit shall have a manual reset high-pressure cutout safety switch and a low-pressure safety cutout switch.
  - D. A [non-fused disconnect switch] [terminal block] and control transformer shall be provided for the [single] [dual] source, main power connection. A terminal board shall be provided for low voltage control wiring.
  - E. The unit control system shall permit starting and stopping of the unit locally or remotely. The keypad/display and monitoring panel shall include a two position "on" or "auto" switch. The control system shall be capable of providing a remote alarm indication. The unit control system shall provide pump start, outside air damper actuation, emergency shutdown, remote heat enable/disable, remote cool enable/disable, heat indication, cool indication, fan interlock and fan operation.
  - F. Unit SCCR rating to be 5 kAIC.
- C. All digital inputs and outputs shall be protected against damage from transients or incorrect voltages. All field wiring shall be terminated at a separate, clearly marked terminal strip.
  - D. A [BACnet MS/TP] [BACnet IP] [Lonworks] communication module shall be provided for direct connection into the BAS network.
  - E. The microprocessor shall have a built-in time schedule. The schedule shall be programmable from the unit keypad interface. The schedule shall be maintained in nonvolatile memory to insure that it is not lost during a power failure. There shall be one start/stop per day and a separate holiday schedule. The controller shall accept up to ten holidays each with up to a 5-day duration. Each unit shall also have the ability to accept a scheduled start/stop command via BAS network communications.
  - F. The unit keypad/display character format shall be 22 characters x 4 lines. The character font shall be 0.144x64 dot matrix. The display shall be a supertwist nematic (STN) LCD display with black characters on yellow background for high visibility. The keypad interface shall be push and roll navigation-button along with three additional function buttons that allow convenient navigation and access to all control functions. All control settings shall be password protected against unauthorized changes. For ease of service, the display format shall be English language readout. The user interaction with the display shall provide the following information as a minimum:
    1. Return air temperature.
    2. Discharge air temperature.
    3. Space air temperature.
    4. Entering condenser water temperature.
    5. Mixed air temperature
    6. Dirty filter indication
    7. Airflow verification.
    8. Supply fan status.
    9. Water economizer valve position
    10. Duct static pressure.
    11. Duct static pressure #2.
    12. Cooling status.
    13. Heating status.
    14. Cooling control method
    15. Control Temperature (changeover)
    16. VAV output status
    17. Fan operation status
    18. Cooling status/capacity
    19. Heating status/capacity
    20. Unit status
    21. All time schedules
    22. Up to ten active alarms w/time & date

## 2.12 CONTROL SYSTEM

- A. Provide a complete integrated microprocessor based control system to control all unit functions including temperature control, duct static pressure control, scheduling, monitoring, unit safeties, including compressor minimum run and minimum off times, and diagnostics. This system shall consist of all required temperature sensors, pressure sensors, controller and keypad/display operator interface. Boards shall be individually replaceable for ease of service. All microprocessors, boards and sensors shall be factory mounted, wired and tested.
- B. The microprocessor will be a stand-alone DDC controller not dependent on communications with any on-site or remote PC or master control panel. The microprocessor will maintain existing set points and operate standalone if the unit loses either direct connect or network communications. The microprocessor memory will be protected from voltage fluctuations as well as any extended power failures. All factory and user set schedules and control points will be maintained in nonvolatile memory. No settings will be lost, even during extended power shutdowns.

- 23. Previous 50 alarms with time & date
- 24. Optimal start
- 25. Purge cycle
- 26. System operating hours
  - a. Fan
  - b. Cooling
  - c. Individual compressor
  - d. Heating
  - e. Economizer
  - f. Tenant override
- G. For the convenience of the end user, alarm indications shall be divided into faults, problems and warnings. "Faults" shall shut down the entire unit and provide information; "problems" shall shut down only the affected component(s) and provide information; "warnings" shall be for information only. Alarms shall include:
  - 1. [Freezestat – Fault]
  - 2. Emergency Shutdown - fault
  - 3. Duct high limit - Fault
  - 4. High return air temperature - Fault
  - 5. High discharge temperature - Fault
  - 6. Low discharge temperature - Fault
  - 7. Fan fail - Fault
  - 8. Sensor failure - Fault or Problem
  - 9. No condenser water flow - Problem
  - 10. Heat fail
  - 11. High pressure (by compressor) - Problem
  - 12. Low pressure/frost (by compressor) - Problem
  - 13. Dirty filter - Warning
  - 14. Airflow (false airflow) - Warning
- H. The user interaction with the keypad shall provide the following set points as a minimum:
  - 1. Control mode
    - a. Off manual
    - b. Auto
    - c. Heat/cool
    - d. Cool only
    - e. Heat only
    - f. Fan only
  - 2. Occupancy mode
    - a. Auto
    - b. Occupied
    - c. Unoccupied
    - d. Tenant override
  - 3. Control temperature (changeover)
    - a. Return air temperature
    - b. Space temperature
    - c. OA temp. (VAV w/ mod. heat)
  - 4. Cooling with dead band
  - 5. Heating with dead band
  - 6. Cooling/heating supply reset options
    - a. Return air temperature
    - b. Outdoor air temperature
    - c. Space temperature
    - d. Airflow (VAV)
    - e. No reset
    - f. Network signal
    - g. External (0-10 VDC or 4-20mA)
  - 7. Temperature alarm limits
    - a. High supply air temperature
    - b. Low supply air temperature
    - c. High return air temperature
  - 8. Lockout control
    - a. Compressor lockout
    - b. Heat lockout
  - 9. Compressor lead-lag on compressors
    - a. Auto
    - b. Disabled
  - 10. Compressor Inter-stage timers
  - 11. Night setback and setup space temp.
  - 12. Duct static pressure reset options
    - a. No reset
    - b. Network
  - 13. Minimum outdoor airflow reset
    - a. Percent of SAF speed
    - b. External reset (0-10 VDC or 4-20mA)
    - c. Fixed outdoor damper position

14. Current time and date.
15. Tenant override time.
16. Occupied/unoccupied time schedule.
17. One event schedule.
18. Holiday dates and duration.
19. Service mode
  - a. Timers normal (all time delays normal)
  - b. Timers fast (all time delays 20 sec.)
  - c. Mode normal (unit on)
- I. The unit control system shall permit starting and stopping of the unit locally or remotely. The keypad/display and monitoring panel shall include a two position "on" or "auto" switch. The control system shall be capable of providing a remote alarm indication. The unit control system shall include pump start, outside air damper actuation, smoke shutdown, emergency shutdown, fan interlock and fan operation.
- J. The unit control system shall have the ability to communicate to an independent Building Automation System (BAS) through a direct communications connection. BACnet Communications shall conform to the BACnet protocol (ANSI/ASHRAE 135-2001 protocol implementation conformance statement (PICS) shall be provided. Multiple units may be connected in a common communications network.] Through communications, the BAS System Integration (SI) Contractor shall be capable of interacting with the individual self-contained unit controllers in the following ways:
  1. Access to [quantity and description from specification] "read only" variables and [quantity and description from specification] "read & write" variables.
  2. Set the unit's operating mode.
  3. Monitor controller inputs, outputs, set points, parameters and alarms.
  4. Change controller set points and configuration parameters.
  5. Clear alarms.
  6. Reset the cooling discharge air temperature set point (DAC units).
  7. Reset the heating discharge air temperature setpoint (DAC units with modulating heat).
  8. Reset the duct static pressure set point (DAC units).
  9. Set the heat/cool changeover temperature (DAC units).
  10. Set the representative zone temperature (SCC units). It will be the responsibility of the SI Contractor to integrate the self-contained unit data into the BAS to affect the integrated building control logic and centralized system workstation interface. It will be the unit manufacturer's responsibility to assist the SI Contractor by providing all necessary documentation.

## 2.13 OPTIONS

- A. The unit shall be supplied with a lockable non-fused main disconnect switch for disconnecting electrical power at the unit. The switch handle shall be visible and accessible without unit entrance.
- B. A phase failure/under voltage protection device shall be provided to protect three-phase motors from damage due to single phasing, phase reversal and low voltage conditions.
- C. A non-averaging type freeze stat shall be factory installed on the entering face of the economizer coil. Upon sensing a freeze condition, the unit supply fan shall be shut down, the economizer valve shall be driven to the full open position and an alarm signal provided. Unit operation shall be restored following the manual reset of the freeze stat.

## PART 3: EXECUTION

### 3.01 INSTALLATION

- A. Install units on a flat surface level within no more than 1/8 inch over the entire unit width.
- B. Install loose components such as isolation pads, duct static pressure sensor tubing and zone thermostats as per manufacturer's literature.
- C. Provide all water piping so unit and water circuits are serviceable, without having to dismantle excessive lengths of pipe.
- D. Provide all water piping so unit and water circuits are serviceable, without having to dismantle excessive lengths of pipe.
- E. Provide drain valves and vent cocks.
- F. Provide certified wiring schematics to the electrical division for associated equipment and controls.
- G. Provide all necessary control wiring as recommended by the manufacturer.





People and ideas you can trust.™

### ***Daikin Applied Training and Development***

Now that you have made an investment in modern, efficient Daikin equipment, its care should be a high priority. For training information on all Daikin HVAC products, please visit us at [www.DaikinApplied.com](http://www.DaikinApplied.com) and click on Training, or call 540-248-9646 and ask for the Training Department.

### ***Warranty***

All Daikin equipment is sold pursuant to its standard terms and conditions of sale, including Limited Product Warranty. Consult your local Daikin Applied representative for warranty details. To find your local Daikin Applied representative, go to [www.DaikinApplied.com](http://www.DaikinApplied.com).

### ***Aftermarket Services***

To find your local parts office, visit [www.DaikinApplied.com](http://www.DaikinApplied.com) or call 800-37PARTS (800-377-2787). To find your local service office, visit [www.DaikinApplied.com](http://www.DaikinApplied.com) or call 800-432-1342.

This document contains the most current product information as of this printing. For the most up-to-date product information, please go to [www.DaikinApplied.com](http://www.DaikinApplied.com).

Products manufactured in an ISO Certified Facility.