

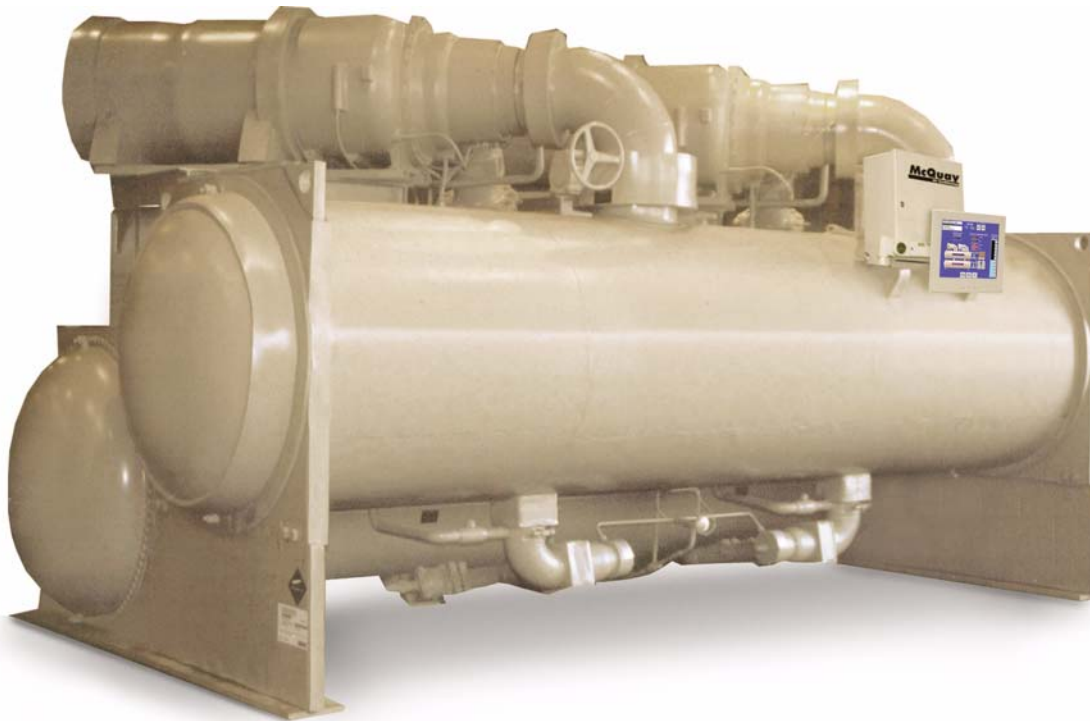

## Centrifugal Compressor Water Chillers

Catalog 605

Models WSC, WDC, WCC, HSC



*Engineered for flexibility and performance™*

## Cutaway view of McQuay Model CE 063 Compressor, Nominal 250 Tons

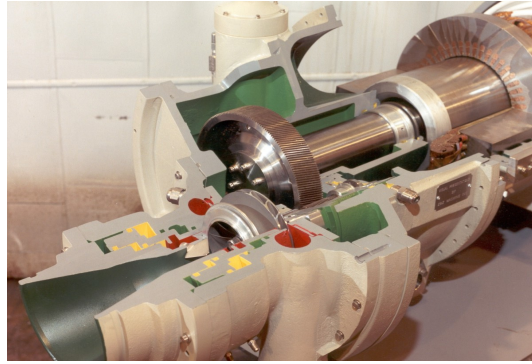

## MicroTech II™ Controller, 15-inch VGA Operator Interface, Home Screen

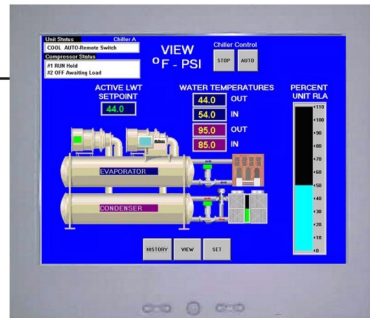
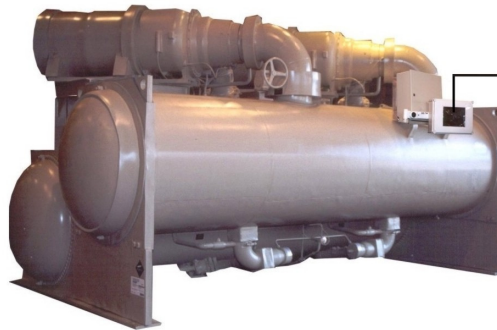

## Table of Contents

Introduction .....	3	Refrigerant Recovery Units .....	41
Customer Benefits Summary .....	5	Refrigerant Monitors .....	41
Dual Compressor Centrifugal Chillers.....	9	Unit Selection.....	42
Heat Recovery Models.....	12	Application Considerations .....	44
Control Features .....	15	Chiller Identification .....	56
Building Automation Systems .....	19	Physical Data and Weights.....	57
Unit Design Features .....	21	Dimensions.....	60
Retrofit Disassembly.....	29	Supplemental Publications .....	73
Options and Accessories.....	35	Specifications .....	74
Motor Controllers .....	37		

Cover pictures: Upper unit: Model WSC 087, 500 ton single compressor chiller with factory-mounted starter  
 Lower unit: Model WDC 126, 2000 ton, dual compressor chiller



\*ETL applies to WSC, WDC, WCC, HSC, HDC only

Document:	Cat 605
Initial Issue:	October 1999
Revision:	January 2010
Replaces:	Cat WSCWDC-7 March 2009

**Manufactured in an ISO Certified Facility**

©2009 McQuay International. Illustrations and data cover the McQuay International product at the time of publication and we reserve the right to make changes in design and construction at anytime without notice.™ The following are trademarks or registered trademarks of their respective companies: BACnet from ASHRAE; LONMARK, LonTalk, LONWORKS, and the LONMARK logo are managed, granted and used by LONMARK International under a license granted by Echelon Corporation; Modbus from Schneider Electric; MicroTech II, Open Choices from McQuay International.

# Introduction

---

McQuay centrifugal chiller products offer customers an unbeatable combination of performance, reliability, unique construction features, a long-term refrigerant, and advanced control technology, all adding up to a superior value.

## ***Model WDC, Dual Compressor Chiller***

- 400 to 2500 tons capacity (ARI conditions)
- Outstanding part load performance
- Duplicate components for excellent reliability
- Refer to page 9 for description

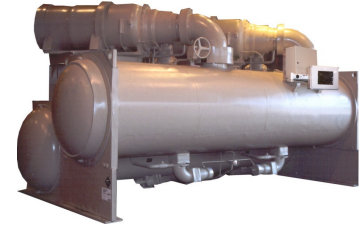

## ***Model WCC, Dual Compressor, Counterflow***

- 1200 to 2700 tons capacity, (ARI conditions, single pass)
- Two refrigerant circuits for true counterflow
- Outstanding full load performance
- Duplicate components for excellent reliability
- Refer to page 9 for description

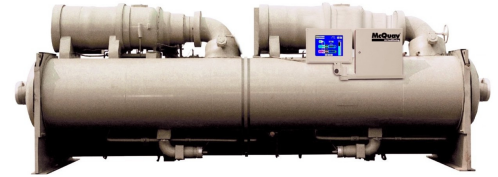

## ***Model WSC, Single Compressor Chiller***

- 200 to 1250 tons capacity (ARI conditions)
- Excellent full load performance
- Refer to page 5 for description



## ***Model HSC, Heat Recovery Chiller***

- Recovers heat normally lost in cooling towers
- Produces simultaneous cooling and heating
- Refer to page 12



## ***Model TSC, Templifier™ Water Heater***

- Recovers waste heat
- 5,000 MBH to 24,000 MBH capacity
- Hot water to 140°F; COP as high as 7
- Refer to page CAT Templifier-1

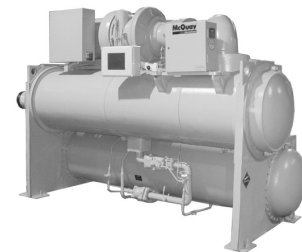

## ***Model WMC, Magnitude™ Magnetic Bearing Compressors***

- Oil-free design, 145 to 400 tons
- Excellent part load performance
- Extremely quiet and vibration free
- See latest edition of CAT 602 for complete details



## Special Applications

McQuay has the ability to design and manufacture special centrifugal compressor chillers with unique design characteristics such as completely packaged, indoor or outdoor chiller plants. Consult your local McQuay sales office.

## Wide Choice of Capacities and Efficiencies

The range of capacities and chiller types shown in the following chart gives the plant designer the ability to pick and choose the exact capacity, optimum chiller type and efficiency for either a single or multiple unit chiller plant. This flexibility is also a tremendous asset for replacement chiller applications.

### McQuay Offers the Widest Choice of ARI Certified, Ozone Safe Centrifugal Chillers

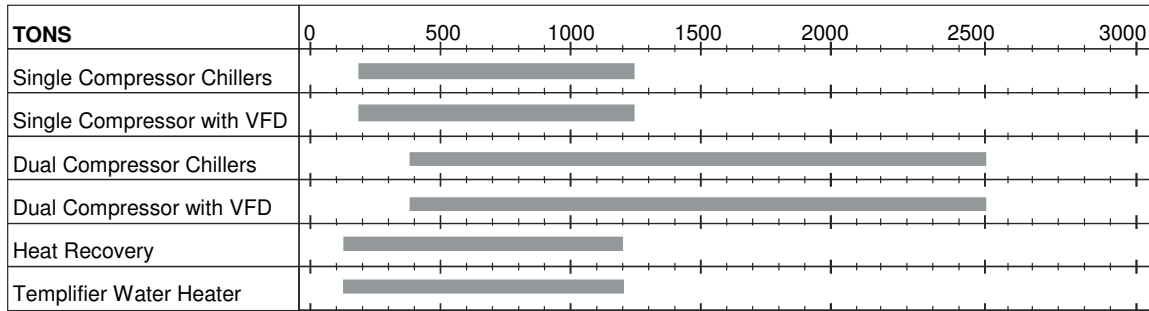

**NOTE:** The upper capacity limit for ARI certification for water-cooled chillers is 2,500 tons. McQuay dual compressor chillers with or without VFD are available up to 2,700 tons.

## MicroTech II® Controller Makes a Difference

### Operator Interface Touch screen

The McQuay 15-inch super VGA touch screen is truly “operator friendly”. All important unit operating data is clearly displayed and selectable at a touch of the screen. Setpoint changes are easy to accomplish and to monitor, reducing errors. Trend data of important parameters and alarm history can be downloaded from a USB port located in the adjacent unit control panel.



### Easy BAS Integration

The McQuay exclusive Open Choices™ feature provides a factory-installed communication module. You select BACnet®, LONMARK® or Modbus® communications for control and monitoring information to be sent to your BAS, without the need for costly gateways.



### Distributed Control

Each chiller has a microprocessor controller for unit functions plus a separate microprocessor for each compressor. Should the operator interface panel and/or the unit controller be unavailable on units above 550 tons, the compressor controller(s) will maintain chiller operation, greatly increasing unit reliability.

# Customer Benefits Summary

---

All McQuay Centrifugal Chiller models offer the following benefits. See the additional referenced pages for details.

## Excellent Performance

It is important to choose a performance philosophy consistent with your application. McQuay has a solution for your specific application. Contact your local McQuay sales office for computer selections of chillers to match your requirements.

The following chart provides recommendations for the model choice for your application.

<u>Application</u>	<u>McQuay Model</u>
Cooling, most hours at full load < 1250 tons	WSC – Single compressor chiller
Cooling, most hours at full load >1250 tons	WCC – Dual compressor chiller
Cooling, most hours at part load	WDC – Dual compressor chiller
Heating application	TSC – Templifier water heater
Simultaneous cooling and heating	HSC – Heat recovery chillers
Optimized part load performance	Variable frequency drive options

## R-134a Refrigerant

All McQuay centrifugal chillers use R-134a instead of R-123 refrigerant, which is still being used by a few manufacturers. R-134a offers the following distinct customer benefits.

### Positive Pressure Design

R-134a chillers operate with the entire system above atmospheric pressure at all times. In the event of a small leak, refrigerant escapes from the chiller to the atmosphere, which allows easy detection and repair. With R-123, air leaks into the system, making leak detection and repair a difficult task.

### No Purge Unit

Even with the best and newest purge units, some refrigerant will be discharged to the atmosphere. Purge units, with their compressor, tanks and piping can be high maintenance components.

### No Annual Lubricant Maintenance

Annual oil maintenance is required with low-pressure designs, increasing owning cost. When air and moisture seep into a negative pressure machine, the acid and corrosion that can form must be removed periodically. McQuay's positive pressure design does not require this maintenance. Under normal operation, the oil charge and filter are good for the life of the unit!

## Sustainable Performance

Although frequently overlooked, an important point to consider when selecting a chiller is the sustainability, over time, of the original purchased performance. All McQuay centrifugal chillers are positive pressure design, using R-134a refrigerant (the first manufacturer to do so) and the chiller performance is sustainable for the life of the unit. On the other hand, chillers using R-123, with negative pressure designs, will lose capacity as air and moisture seep into the refrigeration system. As the volume of air and moisture increases, the performance penalty increases. For example, if a negative pressure design chiller is purchased at 0.58 kW/ton, with the assumption of 100% refrigerant in the unit, the performance, with a 3% penalty for air and moisture contamination, will deteriorate to 0.60 kW/ton. The owner will not be receiving the purchased efficiency. With McQuay's positive pressure design, there is no penalty for non-condensables entering the unit.

## **No Vessel Heating Blankets**

When negative pressure chillers are expected to be inoperative for a long period of time, during winter shutdown for example, it is common to apply an electric heating blanket to the evaporator in order to raise the refrigerant pressure above atmospheric. In other words, try to force it to behave like a McQuay R-134a unit! The initial and operating costs of these blankets are not necessary with a McQuay chiller.

## **No Refrigerant Availability Issue**

R-134a is considered a solution to refrigerant environmental issues because it does not have a phase-out date. R-123 cannot be used in new equipment after the year 2020. History has shown us that a practical refrigerant phase out occurs well in advance of the Montreal Protocol's mandate. Since R-123 has been primarily used only in chillers and only since 1995, there is a limited quantity available for recycling to meet service needs to 2030. It is already capped in the United States and will be reduced to 0.5% by 2020 for service use only until 2030. It is considered highly unlikely that the phase out dates will be extended.

## **Lower Health Risk with McQuay R-134a**

R-134a is listed as an "A1" refrigerant as defined by ASHRAE Standard 15, which means that it has the lowest toxicity and flammability rating. R-123 is rated as "B1", which means it is toxic to humans and also carries a low flammability rating. In the event of a refrigerant release, the likelihood of personnel risk is lower with R-134a.

## **Smaller Equipment Rooms**

As a general rule, the physical size of an R-134a positive pressure chiller will be smaller than a negative pressure chiller, reducing equipment room size. R-123 requires a much larger refrigerant flow rate than R-134a, with a subsequent increase in component size. Also, Equipment room ventilation requirements are greatly reduced when compared to chillers with open drive motors, which reject heat directly into the room ambient air.

# **Gear Drive Advantage**

## **Lower Vibration**

A gear-driven compressor runs at higher impeller rotational speeds but tends to have less vibration than the larger, much heavier, direct drive units. All McQuay compressors must pass a stringent vibration test while running on the production test stands. Spring isolators are normally not required for most applications.

## **Unique Lubrication System**

With the higher rotational speeds and much lighter running components compared to direct drive units, efficient hydrodynamic bearings can be used. The shafts are supported on a film of lubricant, rather than running with metal-to-metal contact, typical of rolling element bearings. Under normal circumstances, the McQuay bearings have a theoretical infinite life while rolling element bearings do not.

## **Selectable Impeller Speeds**

Another gear drive advantage, over the older design direct drive units, is the ability to select gear ratios that will provide the optimum impeller tip speed for a given application. Impeller speeds can be selected to provide sufficient pressure lift ability without the excessive tip speeds that lead to inefficient compressor operation.

Also, the gear options allow for excellent compressor performance on 50 Hertz power.

## Unmatched Unloading

McQuay centrifugal chillers offer unmatched unloading without using inefficient hot gas bypass. This unloading capability provides improved stability of the chilled water temperature and less harmful cycling of compressors. There are significant reasons for this beneficial operating characteristic, including:

### Moveable Diffuser

McQuay has pioneered the use of moveable discharge geometry to lower the surge point of centrifugal compressors. The point at which the compressor enters a stall or surge condition generally limits compressor unloading. At low loads, low gas velocity through a fixed discharge area results in low gas velocities and the gas can stall or surge in the impeller. When in a stall condition, the refrigerant gas is unable to enter the volute due to its low velocity and remains stalled in the impeller. In a surge condition the gas rapidly reverses direction in the impeller causing excessive vibration and heat. McQuay compressors reduce the discharge area as load decreases to maintain gas velocity and greatly reduce the tendency to stall or surge. See page 25 for a complete description.

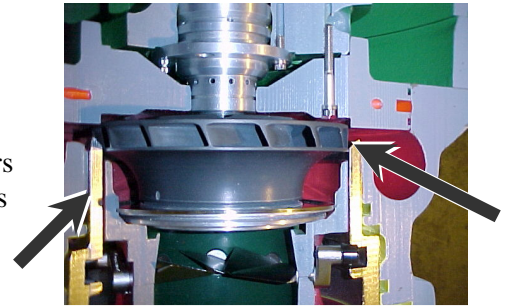

*Moveable diffuser closing off impeller discharge area*

### Thermal Expansion Valve



Pilot expansion valve

Main expansion valve

There are three refrigerant control devices used in the industry, expansion valves, fixed orifices, and float systems. Of the three, only expansion valves, (electronic up to 600 Tons and thermal over 600 Tons) as used by McQuay, offer superior refrigerant management throughout the entire chiller operating range. Expansion valves help McQuay chillers achieve their industry leading capacity reduction capability.

## Quiet Operation

McQuay chillers have two unique features to limit sound generation. One is the unique liquid injection system and the other is that McQuay chillers get quieter as they unload.

### Liquid Injection

A small amount of liquid refrigerant is taken from the condenser and injected into the compressor discharge area. The liquid droplets absorb sound energy and reduce the compressor's overall sound level. The droplets evaporate and reduce discharge superheat.

### Quieter as Chiller Unloads

Many centrifugal compressors become louder as they unload. McQuay's design results in a reduction in sound levels at lower loads, where most chillers spend most of their operating hours.

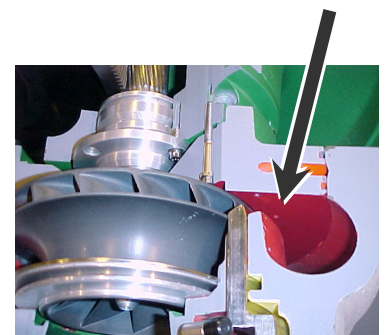

*Radial ports  
inject liquid*

### Power Loss Damage Protection

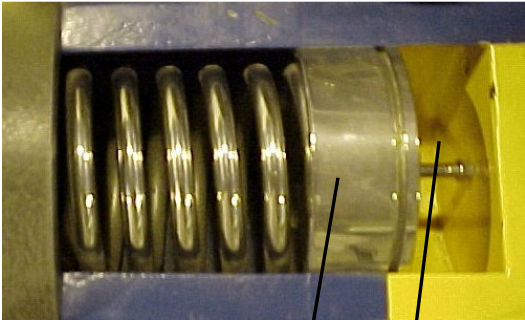

Piston and spring

Lubricant reservoir

Unfortunately, loss of electric power without allowing chillers to proceed through their normal shutdown sequence is becoming common in many areas. When this occurs, most compressors must coast to a stop without benefit of their lubricant pump running. Poor lubrication at this point can damage the bearings and reduce compressor life. McQuay compressors are equipped with a lubricant reservoir and a piston with a compressed spring that provides pressurized lubricant to the bearings during the coast-down period. Also, the compressors decelerate quickly due to the low inertia.

### Refrigerant Storage Capability - Standard

The condensers on McQuay centrifugal chillers are sized to hold the entire chiller refrigerant charge and are provided with the necessary valves to isolate this charge. This feature eliminates the need for separate storage vessels in most applications.

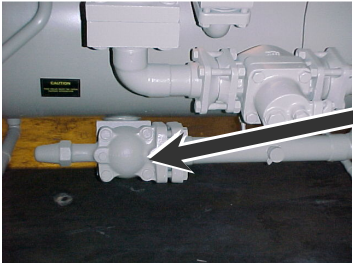

Discharge line check valve combines with main liquid shutoff valve to isolate the condenser



### McQuay Startup

All McQuay centrifugal chillers are commissioned by McQuay Factory Service personnel, or by authorized and experienced McQuay startup technicians. This procedure helps assure that proper starting and checkout procedures are employed and helps in a speedy commissioning process.



# Dual Compressor Centrifugal Chillers

---

## Dual Compressor Experience

McQuay is considered the expert when it comes to dual centrifugal compressor technology. We have been successfully building dual compressor centrifugal chillers since 1971. McQuay is the only company that builds them with either a single refrigerant circuit (Model WDC) or two refrigerant circuits (Model WCC).



**Model WDC, Single Circuit  
Multi-pass**

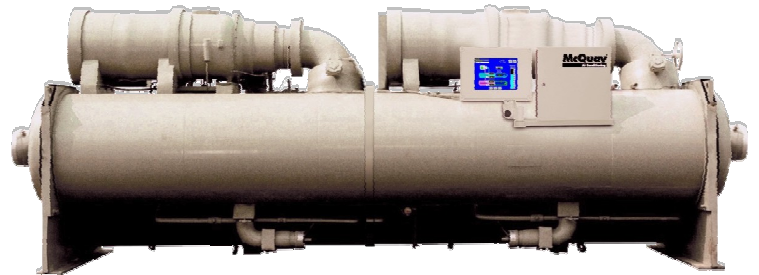

**Model WCC, Dual Circuit  
Single-pass, Counterflow**

## Benefits of Dual Compressor Chillers

### Superior Efficiency

When coupled with McQuay's variable frequency drive, the extremely efficient Dual Compressor Chillers are considerably more efficient than single compressor chillers in the same size range, with IPLVs (Integrated Part load Value) in the low 0.3s kW per ton. IPLV conditions are set by ARI and subject to stringent testing. Insist on ARI certified IPLV efficiency when making efficiency comparisons.

### The Redundancy Feature

The McQuay dual centrifugal chillers *have two of everything*, connected to the evaporator and condenser - two compressors, two lubrication systems, two control systems, two starters.

If any component on a compressor system fails, the component can be removed or repaired without shutting down the other compressor; providing an automatic back-up with at least 60 percent of the chiller design capacity available on WDC units and 50 percent on WCC units.

Redundancy is also built into the distributed control system, which consists of a unit controller, a compressor controller for each compressor and an operator interface touch screen.

- The chiller will operate normally without the touch screen being functional.
- The chiller will operate, with some minor adjustments, without the unit controller. Lead/lag and compressor sequencing will be functional. External control of the cooling tower will be needed.
- If a compressor controller is unavailable, the other compressor will operate normally and handle as much of the load as possible.

## Lower Installed Costs

The redundancy feature pays off in lower installed costs. An example of how to incorporate dual compressor chillers into a system requiring redundancy:

### Job requirement: 1,200 tons (4200 kW), 50% Backup

#### WSC Single Compressor Chillers

(2) 600 ton (2100 kW) On Line Units  
+(1) 600 (2100 kW) ton Standby Unit

#### WDC Dual Compressor Chillers

(2) 750 ton (2100 kW) Units with  
1,200 (4200 kW) On Line tons \*

(3) @ 1,800 ton (6300 kW) Installed Capacity      (2) @ 1500 ton (5250 kW) Installed Capacity

\* One 750-ton (2100 kW) dual chiller running on two compressors for 750 tons (2100 kW), plus one 750-ton (2100 kW) dual chiller running on one compressor for 60% of 750 tons (2100 kW) = 450 tons (1575 kW), for a total of 1200 tons (4200 kW) on any 3 of the 4 total compressors.

The elimination of the extra pumps, valves, piping, controls, rigging, and floor space can result in as much as a 35% reduction in the installation cost for a chiller plant, plus the savings on the chillers themselves.

## Dual Compressor Chiller Overview

There are subtle but important differences between the single circuit WDC and two circuit WCC chillers.

### Dual Circuit, WCC Counterflow Chillers

These chillers have a separate refrigerant circuit for each compressor. They are available in single pass only. They provide the high full load efficiency advantage of two separate chillers arranged for counterflow operation in a single, compact unit.

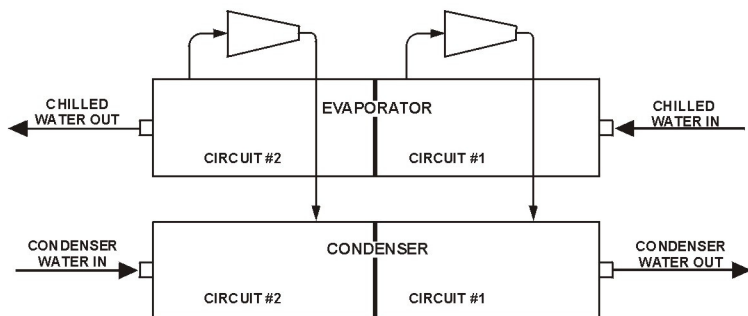

### Single Circuit, WDC Chillers

These chillers have a single-refrigerant circuit for the evaporator and condenser with two compressors running in parallel and are available in one, two or three-pass configurations. Their salient feature is that at single-compressor, part load operation, the running compressor can utilize the entire chiller's heat transfer surface, providing outstanding part load performance.

## Application of Dual Compressor Chillers

Designers and owners must decide which chiller type, or combination of chiller types, is best for their installation. Considerations include first cost, system efficiency, system reliability, space requirements, and total owning costs.

### Use WCC chillers when:

- Project requirement is lowest kW per ton performance at full load with high electrical demand charges.
- Project has a large central plant where cycling chillers for system capacity reduction is expected (three or more chillers).
- High chilled water delta-T and low water pressure drops are desired.
- Built-in redundancy is required. A single compressor will provide 50% of the unit's full load capacity.
- High efficiency and large capacity is required with series flow. Use two WCC units in series-counterflow in the 3,000 to 4,000 ton range.

### Use WDC chillers when:

- Project requirement is overall lowest energy consumption with best part load performance.
- Project has smaller chilled water plant where unit unloading is expected versus cycling of chillers associated with large multi-chiller plants.
- Floor space is limited (16-foot vessel length compared to 20-foot for WCC).
- Two or three pass vessels are required, typical of retrofit applications.

- Built-in redundancy is required. A single compressor will provide 60% of the unit's full load capacity.

### Use a combination of WDC and WCC chillers when:

- Peak overall system efficiency is important; for example, use three WCC and one WDC chiller, all in parallel. The WCC units are optimized for running at full load and the WDC is optimized for part load operation. The WCC units cycle on and off and the WDC unit (consider variable frequency drives on this unit) trims the load, running between five and one hundred percent capacity.

## Why a Compressor Motor Failure Will Not Contaminate the Common Refrigerant Circuit on WDC dual chillers

Some people are concerned with result of a motor burnout on a single-circuit chiller. This is not a problem on the McQuay WDC chillers because of compressor construction and chiller layout.

The compressor motor is isolated from the main refrigerant flow circuit so that any contaminants generated by a motor failure will not pass into the main refrigerant circuit. Moisture, acid and/or carbon particles will be automatically trapped within the compressor's dedicated coolant feed and exit lines.

Internally, the compressor motor compartment is separated and sealed from the main refrigerant compression chamber. A double shaft seal on the motor side of the gear housing prevents cross flow of refrigerant along the motor shaft. The motor coolant feed line is equipped with both a solenoid valve and a check valve. These mechanical components, plus the higher pressure of the liquid refrigerant, prevent back feed into the main refrigerant system. Refrigerant vapor exiting the motor compartment must pass through a high pressure drop filter-drier, sized to immediately plug up and seal off the motor compartment. Both the coolant feed and return lines are equipped with manual shutoff valves to permit component service.

Over 30 years of field experience have proven the reliability of these compressor motors. Despite the reliability inherent in the motor design and the protective control, electrical distribution system faults and lightning strikes can occur that are beyond the control of the most conscientious designer. The coolant protective system protects the unit charge from being contaminated.

**Special WDC Warranty:** In the unlikely event of a motor burnout, the chiller refrigerant charge *will not be contaminated*. This is so well proven that it is *guaranteed for five years*. In areas supported by McQuay Factory Service, if a motor burnout occurs in one compressor and contaminates the refrigerant circuit, any resultant damage to the other compressor will be repaired and the refrigerant charge replaced at no cost to the customer for parts and labor. The terms of the original chiller warranty apply to the original burned out compressor.

**Figure 1, Motor Cooling**

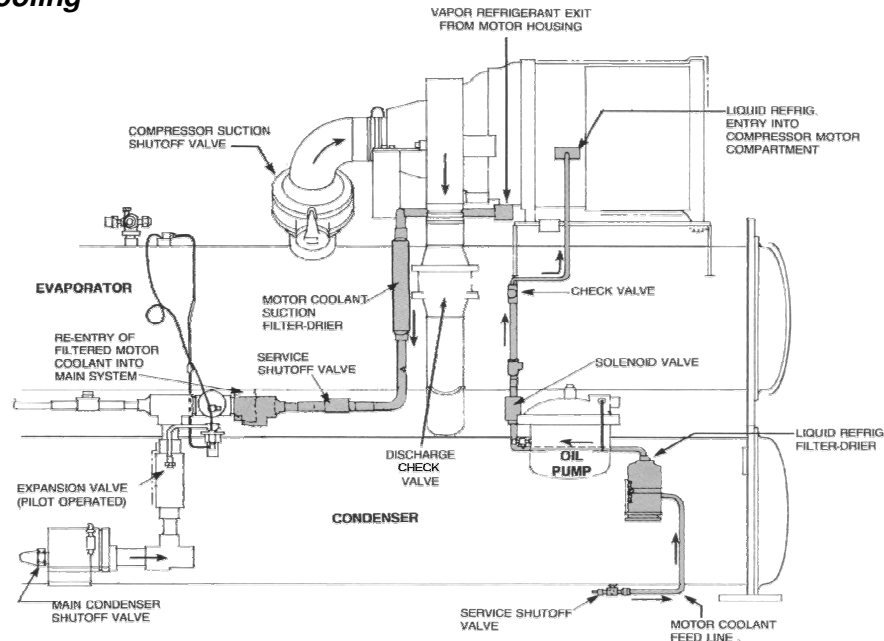

## Efficiency

Chillers usually spend 99% of their operating hours under part load conditions, and most of this time at less than 60% of design capacity. One compressor of a dual WDC chiller operates with the full heat transfer surface of the entire unit. For example, one 500-ton (1,750 kW) compressor on a 1,000 ton (3,500 kW) dual chiller utilizes 1,000 tons (3500 kW) of evaporator and condenser surface. This increases the compressor's capacity and also results in very high efficiency.

Typical efficiencies for a WDC dual chiller, taken from a selection computer run, look like this:

- Full load efficiency 0.550 kW per ton (6.5 COP)
- 60% load, one compressor 0.364 kW per ton (9.6 COP)
- IPLV 0.415 kW per ton (8.5COP)

The addition of VFDs to the WDC dual compressor chiller produces an astonishing ARI certified IPLV of 0.340 for the above case. Specific selections can vary up or down from this example. IPLV is defined in the Selection section of this manual beginning on page 42.

WCC chillers, with their counterflow design, excel at full load efficiency. Each of the two compressors operates at a lower head (pressure differential) than single compressor chillers in parallel. With any pump or compressor, lower head means lower power for a given flow. As shown on the right, the #2 (downstream compressor) makes 42°F water but has only 89°F condenser water leaving instead of 95°F typical of a single compressor unit. The #1 compressor has 95°F condenser water leaving, but only has to make 47.6 °F chilled water.

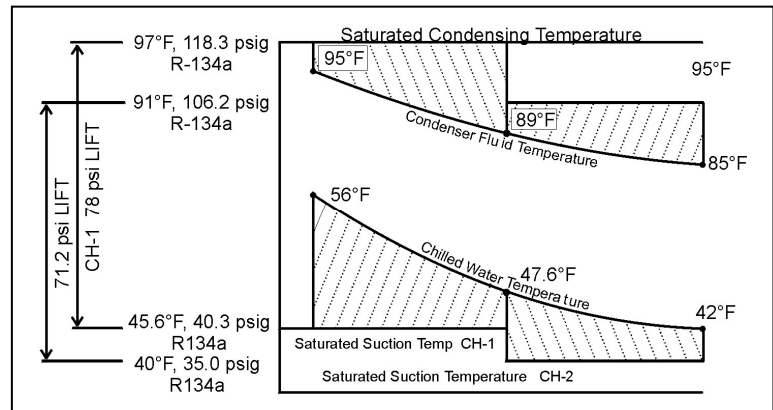

## The Replacement Market Advantage

- Bolt-together construction on single and dual compressor chillers along with factory disassembly available as an option simply the tough entrance situations.
- Put 20% or more tons in the same footprint.
- Add dual compressor redundancy.
- Greatly reduce chiller energy consumption.
- Install a refrigerant with no phase-out date.
- Opens many options for multiple chiller plants using WSC, WDC and WCC combinations.

## Heat Recovery Models

For decades, McQuay International has pioneered the use of heat recovery chillers and the unique McQuay Templifier™ Heat Pump Water Heater to reduce energy costs. These products have become more important than ever with the current emphasis on total building efficiency. ASHRAE Efficiency Standard 90.1 mandates the use of heat recovery equipment of this type in a wide range of buildings.

### Heat Recovery Chillers

The heat recovery chillers, Models HSC with a single compressor, have a single condenser with split bundles, i.e., two separate water passages divided by separate water heads as shown in the photograph to the right. The inboard water connections are connected to the cooling tower, the other water side is connected to the heating system.

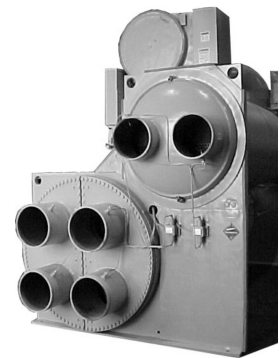

The economic feasibility of hot water generated with these units depends on heating and cooling load profiles and on the relative cost of the available energy sources. A compressor's kw per ton is heavily influenced by the pressure head it is pumping against. During heat recovery operation, the entire cooling load is operating against

the high head required by the hot water temperature. For this reason, it is desirable to maximize the percentage of the total rejected heat used for the heating load.

McQuay's economic evaluation program, *Energy Analyzer*<sup>TM</sup>, available on CD from your local McQuay sales office, is the perfect tool to determine the economic feasibility of using this proven technology.

**Figure 2, Heat Recovery Chiller Piping Schematic**

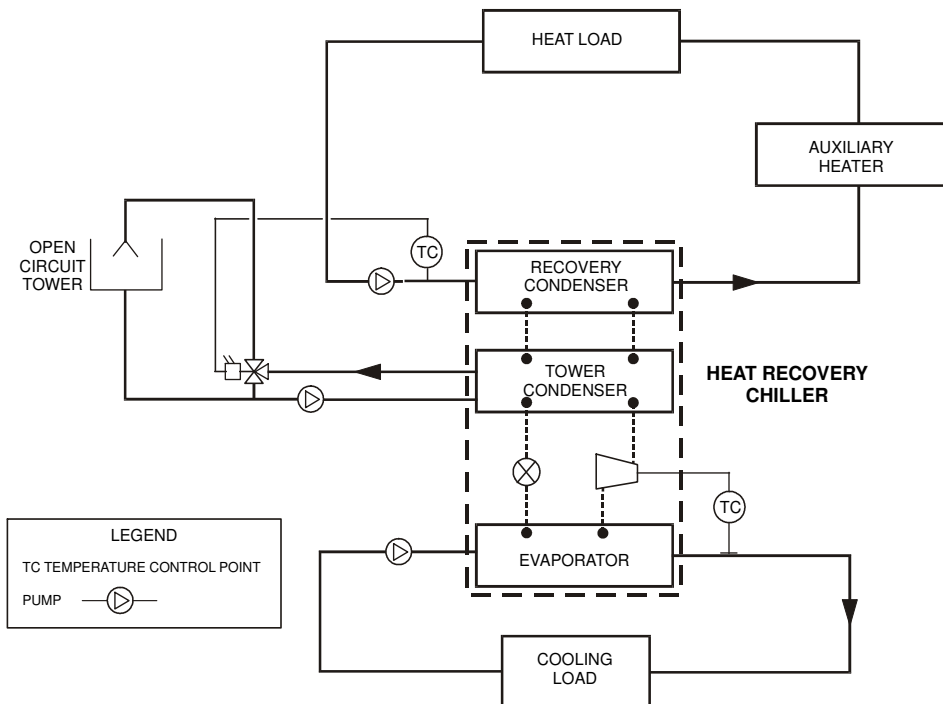

### Templifier<sup>TM</sup> Heat Pump Water Heaters

#### Model TSC: 5,000 to 24,000 MBH

The Model TSC Templifier was developed in the 1970s, after the 1973 oil embargo, as a device to replace fossil-fired water heaters with electric heaters. The concept was simple; direct a stream of warm waste heat to the evaporator of a refrigeration unit, amplify the temperature of the heat through the compression cycle, and then deliver the heat from the condenser, at a higher useful temperature, to a heating load.

The flow diagram shown to the left illustrates just how the Templifier unit is placed in a chilled water system. The decision to include a Templifier water heater is almost always a financial one. Evaluation of load profiles, energy costs, and owning costs is made simple by using the McQuay *Energy Analyzer*<sup>TM</sup> evaluation program to determine if the return on investment meets the owner's requirements.

When there is sufficient waste heat available, Templifier units can be very attractive where fossil fuels are not available, or where their use is restricted due to pollution problems or other reasons. Compared to electric resistance heating, the energy cost for a Templifier unit to heat domestic water, for example, could be 7 to 8 times less!

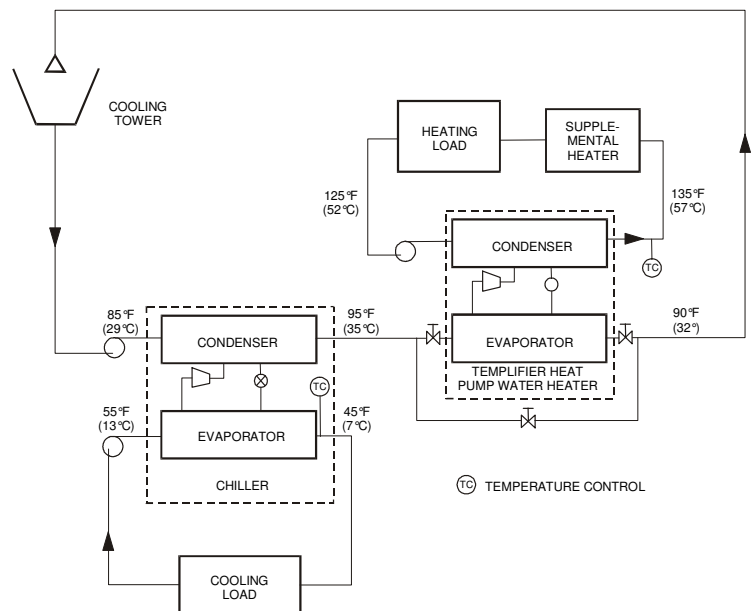

## Where to Use Templifier Water Heaters

### Typical Building Types

- Hotels/Motels
- Health Care
- Athletic Facilities
- Resorts
- Schools
- Food Service
- Nursing Homes

### Typical Applications

- Space Heating
- Outside Air Heating
- Reheat
- Service Hot Water
- Laundries
- Kitchens

## Typical COPs

Hot Water Temperatures	110°F	120°F	130°F	140°F
COP (Based on 85°F off Chiller to Templifier)	8.3	6.8	6.0	4.5

The Templifier Water heater has also found innumerable applications in industries such as food processing, recovering waste heat and supplying hot process water, as high as 140°F, at high COPs and low cost. See the McQuay *PM Templifier* catalog for additional information.

## Typical Templifier Applications

### Service Hot Water Piping

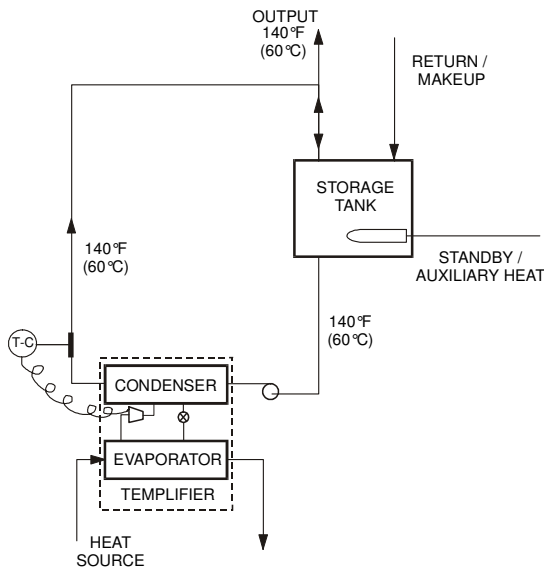

### Intermediate Heat Exchanger Ground Water Heat Source

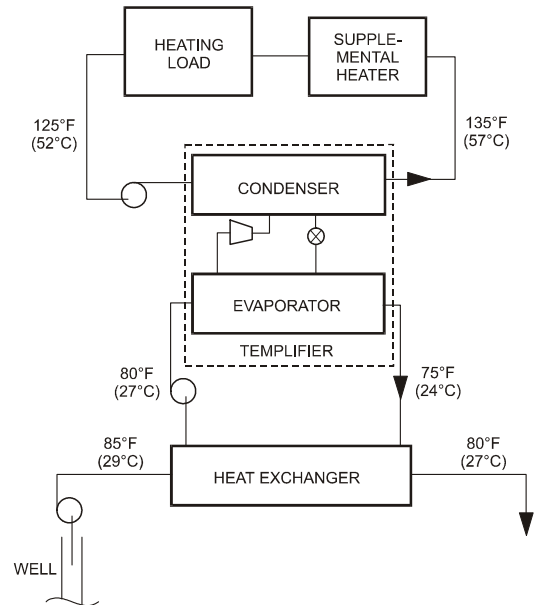

# Control Features

---

## Chillers Feature MicroTech II® Controls

McQuay has incorporated the latest microprocessor technology into the MicroTech II control system to give you the ultimate in chiller control. The control includes many energy-saving features to keep your chiller running efficiently . . . day in, day out, for years to come.

### **Figure 3, Unit Controller and Operator Interface Touch Screen**

The unit controller and operator interface touch screen mounted on a chiller unit are shown to the right. The 15-inch VGA touch screen is on an adjustable arm so that it can be positioned comfortably for each operator. The control panel contains a USB port from which trend data and manuals can be conveniently downloaded. All-important unit operating data is easily accessed and viewed. Password protected unit setpoints, complete with description and setting range, are available at the touch of a screen.



### **Figure 4, Compressor Controller**

A major feature of the MicroTech II controller, as applied to chillers, is the distributive control scheme. The picture to the right shows the compressor control panel (with its cover removed) mounted at the rear of the unit, adjacent to the compressor itself. This panel also contains the oil pump contactor and overload. Model WDC dual compressor chillers have two such panels. Also on the pLAN (control network) is the unit controller and operator interface touch screen. If the interface touch screen and/or unit controller is out of service, the chiller can continue to operate on the compressor controller alone. This feature provides unprecedented reliability in a chiller control system.

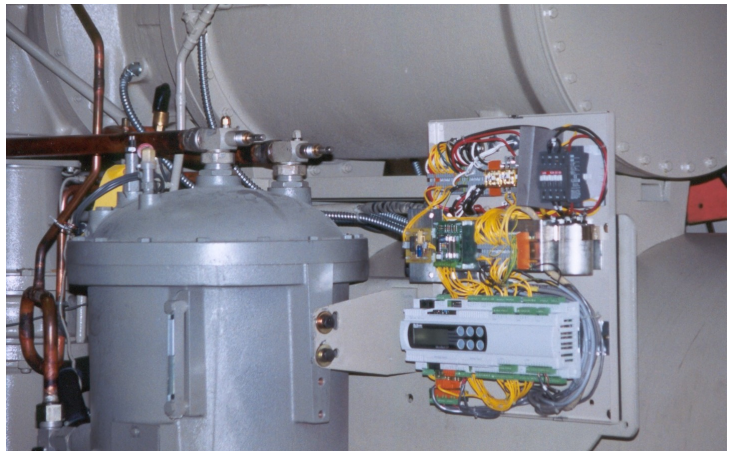

## MicroTech II Features and Benefits

FEATURE	BENEFIT
Easy integration into a building management system via a factory or field-installed module communicating with BACnet®, LONMARK® or Modbus® protocols.	Designer can select any BAS supplier using industry standard protocols and know the MicroTech II control will easily interface directly with it.
Easy to read, adjustable, 15-inch, Super VGA color touch screen operator interface	Operators can observe chiller operation at a glance, easily select various detail screens and change setpoints
Historic trend data-can be downloaded from an onboard USB port	Water temperatures, refrigerant pressures, and motor load plots can provide valuable unit operation data
Precise $\pm 0.2$ °F chilled water control	Provides stability in chilled water system
Proactive pre-shutdown correction of “unusual conditions” allows chiller to stay online	Activates alarm and modifies chiller operation to provide maximum possible cooling
Automatic control of chilled water and condenser water pumps	Integrated lead/lag and automatic engagement of backup pump
Controls up to four stages of tower fans and modulation of tower fan and/or bypass valve	Optimum integrated control of cooling tower water based on system conditions
Twenty-five previous alarm descriptions are stored in memory	Invaluable asset in troubleshooting
Multiple language capability Metric or in-lb units of measure	Great asset for world-wide applications

### Designed with the System Operator in Mind

Reliable, economic use of any chiller depends largely on an easy operator interface. That’s why operation simplicity was one of the main considerations in the development of the MicroTech II controller. The operator interface with the chiller is a 15-inch, Super VGA color touch-screen. The operator can clearly see the entire chiller graphically displayed, with key operating parameters viewable on the screen. Other screens, such as alarm history and setpoints, are easily accessed through touch screen buttons.

We have even gone as far as installing the unit operating and maintenance manual, as well as the parts list, in the chiller’s microprocessor memory, so that they are viewable on the touch screen or can be downloaded to a computer through the onboard USB port.

### Proactive Control

By constantly monitoring chiller status, the MicroTech II controller will automatically take proactive measures to relieve abnormal conditions or shut the unit down if a fault occurs. For example, if a problem occurs in the cooling tower and discharge pressure starts to rise, the controller will automatically hold the load point and activate an alarm signal. A further rise in pressure will initiate compressor unloading in an effort to maintain the setpoint pressure. If the pressure continues to rise, the unit will shut off at the cutout pressure setting.

### Alarm History for Easy Troubleshooting

The MicroTech II controller's memory retains a record of faults and a time/date stamp. The controller's memory (no batteries required) can retain and display the cause of the current fault and the last twenty-five



fault conditions. This method for retaining the fault is extremely useful for troubleshooting and maintaining an accurate record of unit performance and history.

The MicroTech II controller features a three-level password security system to provide protection against unauthorized use.

The Home Screen shown at right is the primary viewing screen. It gives real time data on unit status, water temperatures, chilled water setpoint and motor amp draw. This display instantly answers the vital question-is the chiller doing what it is supposed to be doing?

If an alarm occurs, a red button appears on the screen (a remote signal is also available). Pressing this button accesses the Active Fault Screen that gives complete fault information. The fault can be corrected and cleared at this point.

### Changing Setpoints

Changing setpoints is easy with the MicroTech II control.

For example, to change the chilled water setpoint, press SET button from any screen, then press WATER and this screen appears, now press button #1, Leaving Water Temperature, and you are ready to input a password and a new value.

### Trend Logging

Ever wonder how your chiller performed last night? Were you holding the correct chilled water temperature? What kind of cooling load did the chiller have? The McQuay MicroTech II controller can provide the answers, thanks to its huge memory, and plot water temperatures, refrigerant pressures, and motor load data. These values can also be downloaded through a convenient USB port, located in the unit control panel, and pasted into a spreadsheet for archiving or further detailed evaluation.

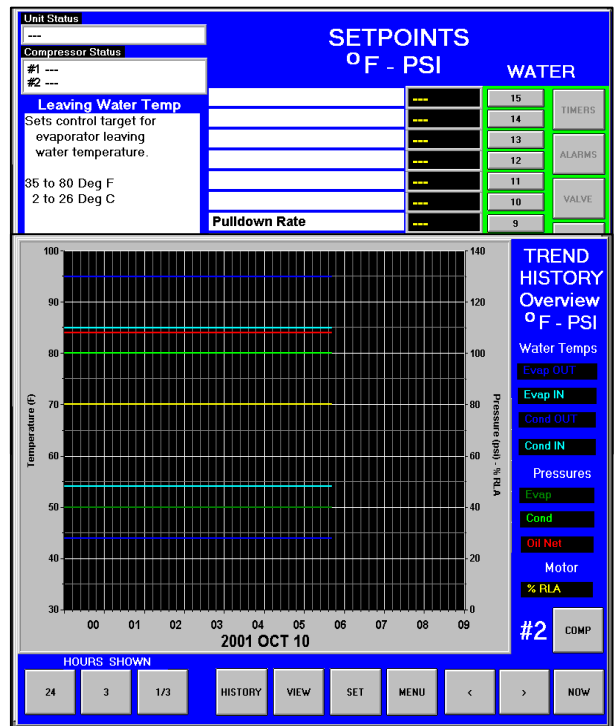
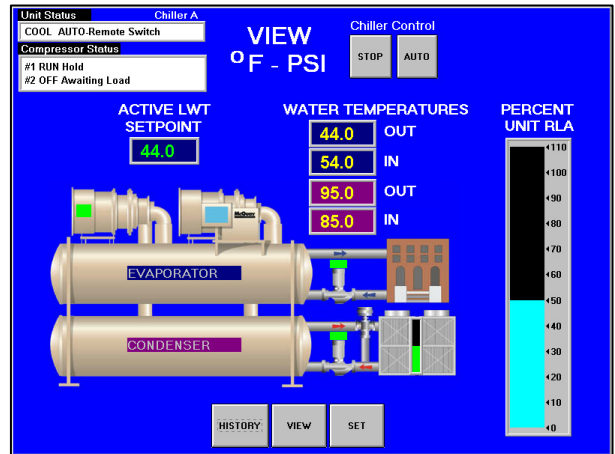

## MicroTech II Controller Increases Chiller Operating Economy

Many standard features have been incorporated into MicroTech II control in order to maintain the operating economy of McQuay centrifugal chillers. In addition to replacing normal relay logic circuits, we've enhanced the controller's energy saving capabilities with the following features:

- Direct control of water pumps. Optically isolated, digital output relays provide automatic lead-lag of the evaporator and condenser pumps, permitting pump operation only when required.
- User-programmable compressor soft loading. Prevents excessive power draw during pull down from high chilled water temperature conditions.
- Chilled-water reset. Accomplished directly on the unit by resetting the leaving water temperature based on the return water temperature, a remote 4-20 ma or a 1-5 VDC BAS signal. Raising the chilled water setpoint during periods of light loads dramatically reduces power consumption.
- Demand limit control. Maximum motor current draw can be set on the panel, or can be adjusted from a remote 4-20ma or 1-5 VDC BAS signal. This feature controls maximum demand charges during high usage periods.
- Condenser water temperature control. Capable of four stages of tower fan control, plus an optional analog control of either a three-way tower-bypass valve or variable speed tower-fan motor. Stages are controlled from condenser-water temperature. The three-way valve can be controlled to a different water temperature or track the current tower stage. This allows optimum chilled water plant performance based upon specific job requirements.
- Staging Options (Multiple Chiller Installations). The MicroTech II controller is capable of compressor staging decisions and balancing compressor loads between up to four McQuay chillers using defaults or operator-defined staging.
- Plotting Historic Trends. Past operation of the chiller can be plotted as trend lines and even downloaded to spread sheets for evaluation - a valuable tool for optimizing efficiency.

### Starter Data Displayed

As standard, the percent of unit rated load amps (RLA) is displayed on the interface screen as a bar chart. In addition, there are two options available to display additional starter data on screen. The options are:

- Ammeter Display, which displays phase amps and average amps
- Full Metering Display, which displays phase and average amps, phase and average volts, compressor kilowatts, power factor and unit kilowatt-hours.

These options, in particular the full metering option, give the owner/operator a great deal of valuable electrical power information on an easily accessed screen. They are available on solid state, across-the-line and wye-delta starters up to 6600 volts.

### WDC/WCC Chiller Controls

Each model WDC or WCC dual compressor chiller comes complete with its own factory-mounted and wired MicroTech II controller system featuring:

- 15-inch color touch screen operator interface panel
- Microprocessor-based unit controller
- Microprocessor-based controller for each compressor

This distributed control scheme allows the operation of each compressor independently from the other.

Elapsed time, number of starts, percent RLA; are all monitored separately by each MicroTech II control panel. In addition, individual compressor fault history, setpoint control, loading functions, time of day starts, etc., can be controlled and monitored on the interface panel.

Compressor staging and the load balance function are standard features of each MicroTech II control. Smart scheduling starts the compressor with the fewest number of starts first, and will only start remaining compressors when proof of sufficient load has been established. The staging function will stop the compressor with the most run-hours when the load decreases to single compressor range. During two-compressor operation, the load balance function will equalize the load between each compressor, providing optimum unit efficiency.

### **25% or greater annual kWh savings when operating below 60% of design capacity**

The majority of comfort cooling systems operate at 60% or less of building design tons for most of the year. A great number of those operating hours occur between 50% and 60% design cooling capacity.

For that reason, the Model WDC chiller was designed to produce up to 60% unit capacity with a single operating compressor, efficiently and reliably.

That performance is achieved by a combination of individual component features that include compressor design, operating control, double heat transfer surface, and refrigerant flow control.

### **Versatile Communications Capabilities Give You Even More Control**

For complete flexibility there are three ways to interface with the MicroTech II controller:

1. Direct entry and readout locally at the controller's operator interface panel on the unit.
2. Direct entry as above, plus remote digital and analog input/output signals for certain functions such as enable run input, alarm signal output, 4-20ma or 0-5 VDC inputs for chilled water reset and load limiting, outputs for pump and tower fan control, analog output for variable speed tower fan and/or tower bypass valve.
3. Interface with a building automation system (BAS) with optional factory- or field-installed modules, communicating directly with BACnet®, LONMARK® or Modbus® protocols.

## **Building Automation Systems**

---

All MicroTech II controllers are capable of communications, providing seamless integration and comprehensive monitoring, control, and two-way data exchange with industry standard protocols such as LONMARK®, Modbus® or BACnet®.

### **Open Choices™ Benefits**

- Easy to integrate into your building automation system of choice
- Factory-installed and tested or field-installed communication modules
- Comprehensive point list for system integration, equipment monitoring and alarm notification
- Provides efficient equipment operation
- Owner/designer can select the BAS that best meets building requirements
- Comprehensive data exchange

### **Integration Made Easy**

McQuay unit controllers strictly conform to the interoperability guidelines of the LONMARK® Interoperability Association and the BACnet Manufacturers Association. They have received:

- LONMARK certification with the optional LONWORKS communication module

### **Protocol Options**

- BACnet MS/TP
- BACnet IP
- BACnet Ethernet
- LONWORKS® (FTT-10A)
- Modbus RTU

The BAS communication module can be ordered with a chiller and factory-mounted or can be field-installed at any time after the chiller unit is installed.

## Electric Power Options

In order for the BAS to read the full complement of power data on low and medium voltage solid state, across-the-line, and wye-delta starters, the optional Field Metering Package must be ordered with the chiller. Otherwise the BAS will only read the average unit amps.

This power data is not available to a BAS on all other starter voltages and types.

**Table 1, Typical Data Point Availability**

Typical Data Points <sup>1</sup> (W = Write, R = Read)					
Active Setpoint	R	Cond EWT	R	Evap Water Pump Status	R
Actual Capacity	R	Cond Flow Switch Status	R	Heat Recovery EWT	R
Capacity Limit Output	R	Cond LWT	R	Heat Recovery LWT	R
Capacity Limit Setpoint	W	Cond Pump Run Hours	R	Heat Setpoint	W
Chiller Enable	W	Cond Refrigerant Pressure	R <sup>2</sup>	Ice Setpoint	W
Chiller Limited	R	Cond Sat. Refrigerant Temp	R <sup>2</sup>	Liquid Line Refrigerant Pressure	
Chiller Local/Remote	R	Cond Water Pump Status	R	Liquid Line Refrigerant Temp	R
Chiller Mode Output	R	Cool Setpoint	W	Maximum Send Time	W
Chiller Mode Setpoint	W	Current Alarm	R	Minimum Send Time	W
Chiller On/Off	R	Default Values	W	Network Clear Alarm	W
Chiller Status	R	Evap EWT	R	Oil Feed Pressure	R
Compressor Discharge Temp	R	Evap Flow Switch Status	R	Oil Feed Temp	R
Compressor Percent RLA	R	Evap LWT for Unit	R	Oil Sump Pressure	R
Compressor Run Hours	R	Evap LWT for Compressor	R	Oil Sump Temp	R
Compressor Select	W	Evap Pump Run Hours	R	Outdoor Air Temp	
Compressor Starts	R	Evap Refrigerant Pressure	R <sup>2</sup>	Pump Select	W
Compressor Suction Line Temp	R	Evap Sat. Refrigerant Temp	R <sup>2</sup>	Run Enabled	R

**Notes:**

1. Data points available are dependent upon options selected
2. Per compressor

**Figure 5, Sample System Architecture**

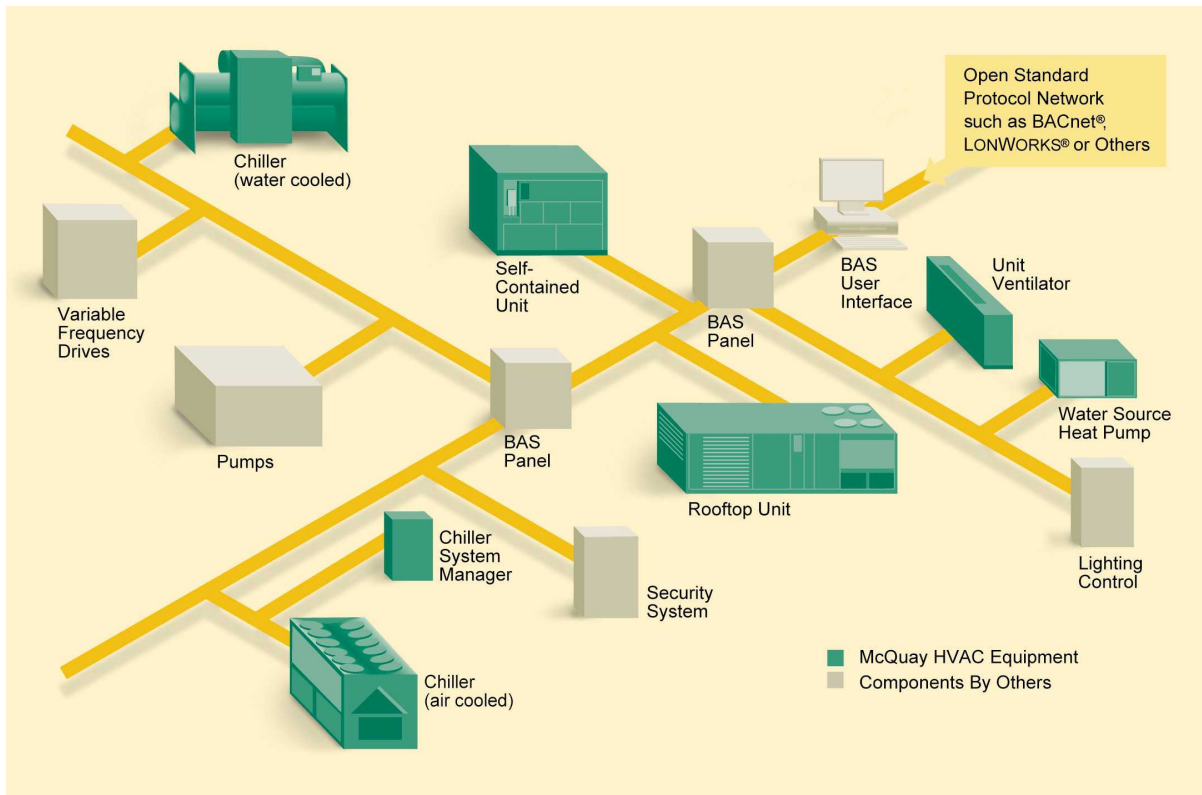

# Unit Design Features

---

## Compressor Design

### Gear-Drive Offers Greater Operating Efficiency Than Direct Drive

Centrifugal compressor efficiency is a function of impeller design and application to the refrigeration system. The increased heat transfer surface and efficiency of modern heat exchangers have changed compressor head and impeller tip speed requirements. Direct-drive designs limit the manufacturer's ability, within a single compressor size, to select impellers at or near peak impeller efficiency. While a unit selected at poor impeller efficiency might produce the required performance at peak load, its operating characteristics over the entire range of part load performance are sharply curtailed, resulting in increased annual operating costs.

McQuay gear-drive centrifugal chillers provide a variety of tip speed ratios to permit selection of impellers for maximum efficiency over their entire part load to full load range and are also ideal for 50 Hz application. Mechanical gear losses are limited by design standards to less than one-half of 1%. The impeller efficiency obtained by alternate gear selections can increase chiller efficiency by as much as 7%.

As energy costs continue to rise, the economic advantages of gear drive to obtain maximum efficiencies will be even more advantageous. The efficiency of either direct-drive or gear-drive compressor can be improved through the use of variable frequency drives to reduce compressor speed at low load/low head conditions.

### Extended Motor Life

McQuay's modern compact compressor design provides many operating advantages that improve its overall reliability and durability. One such advantage is prolonged motor life. A motor draws locked rotor current until it reaches break-away torque at approximately 80% of its running speed. While drawing locked rotor current, the stresses on the motor are over six times that of full load. The McQuay compressors absolutely minimize this stress through the unique gear drive and light weight drive train that allows a 500-ton (1750 kW) compressor to reach running speed in less than three seconds. The owner benefits from a longer motor life.

### The REAL FACTS on Speed, RPM and Tip Speed in Centrifugal Compressors

The question: "How fast does it spin?" is common when discussing compressors. There is a widespread concept that the impeller rotating speed (rpm) is the determining factor in the life, reliability, and efficiency of the compressor. *This is absolutely false.* An engineering examination will show that rpm, as an absolute, is not considered in the design of rotating mechanical components. It is the combination of velocity of the outside edge of the impeller (tip speed), mass, and physical size that define the design criteria for these components. Shaft, bearing, and impeller design is based on parameters such as surface velocity, diameter, weight, rotational and torsional critical speed, as well as the type of material and lubrication system used.

**Stress on an impeller is proportional to the square of the tip speed. Rotational speed is only part of the equation along with impeller diameter.**

In centrifugal compressor design, two parameters, impeller diameter and impeller tip speed, must be determined. Impeller diameter is determined by the required volume flow rate supplied to the inlet of the impeller. Refrigerants which operate at a negative pressure such as HCFC-123 have high cfm/ton ( $\text{m}^3/\text{kW}$ ) flow rates and require larger diameter impellers and refrigerant lines to keep pressure drop to reasonable levels.

Systems with refrigerants that operate at a positive pressure, such as R-134a, have smaller impellers and gas lines since these refrigerants require lower gas flow rates. R-123 requires approximately six times the gas flow rate in cfm per ton than R-134a. At ARI standard conditions, 18.1 cfm (8.54 l/sec) of R-123 is required per ton of refrigeration. Contrast this to R-134a that requires only 3.2 cfm (1.5 l/sec) per ton. This means that for a given capacity, the cross-sectional area of the impeller inlet "wheel eye" as well as the

suction and discharge lines will be six times larger for R-123 than for R-134a at equivalent pressure drops. The wheel eye diameter is the major factor in determining the overall impeller diameter and geometry.

Designers of centrifugal equipment must also consider the tip speed requirement. To produce the required pressure difference or lift, a centrifugal impeller must achieve a given tip speed. Tip speed is the velocity of the "tip" of the impeller relative to its surroundings. Imagine an observer standing on the impeller. The observer sees his surroundings pass by him at a certain velocity. This velocity is the impeller tip speed, usually expressed in feet per second (meters per second). An analogy can be drawn to a car driving down a road. The tip speed of the tire is equal to the speed of the car.

Since all the refrigerants that have been discussed require tip speeds in the range of 670 to 700 ft/sec (204 to 213 m/sec), we see that the impeller angular velocity (rpm) is largely affected by its diameter. It was pointed out earlier that negative pressure impellers must be larger than those in positive pressure machines due to the drastic differences in required gas flow rates. Larger diameter impellers must rotate at slower rpm than smaller diameter impellers. Referring again to the car example demonstrates that different combinations of diameter and rpm produce the same tip speed. Imagine a freeway carrying vehicles with different size tires all traveling at 55 mph. The tip speed of all of the tires is fixed at 55 mph even though the small tires of a utility trailer rotate at a much higher rpm than the tires of a tractor-trailer.

The relationship of diameter and tip speed can be shown by the following equation:

$$RPM = [TipSpeed(fps) \times 229.2] / Diameter(in.)$$

$$RPM = [TipSpeed(m/s) \times 1910] / Diameter(cm.)$$

Again, this indicates that for a given speed requirement, a smaller diameter impeller in a compressor will operate at a higher rpm than a larger diameter impeller. Again:

**Stress is proportional to the tip speed<sup>2</sup>:** Impellers with similar *tip speeds* have similar stress.

#### **Quiet, stable capacity during unloading without hot gas bypass**

Compressor capacity on McQuay chillers is maximized at full load and modulated for part-load conditions by interlocked inlet guide vanes and the movable discharge geometry. This McQuay design innovation has real owner benefits. Most centrifugal compressors do not unload well and waste energy at low load conditions by unnecessary compressor cycling or by the use of inefficient hot gas bypass.

#### **No leakage at the capacity control mechanism**

An oil pressure operated, guide vane activating piston is internally mounted and powered, eliminating leakage from external linkage and seals. The vanes are positioned in response to variation in leaving chiller water temperature. A built-in compensating control allows automatic override of normal operation to close the vanes for low suction pressure or current limiting duty.

**Figure 6, HFC 134a Impeller Compared to R-123 Impeller**

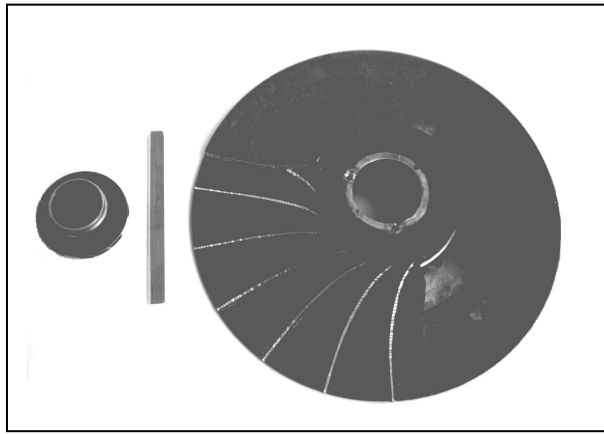

Left: Impeller from a McQuay single-stage, 300 ton (1050 kW) compressor; diameter = 6.3 in. (16 cm), weight = 3.0 lb (1.4 kg)

Right: One of *three* impellers from a 300 ton negative pressure compressor; diameter = 26 in. (66 cm), weight = 27 lb. 12.2 kg)

### Single Stage Simplicity = Savings

Compressor efficiency is **not** a function of multiple impellers. Maintenance of optimum efficiency at peak and, more importantly, at part load, is a function of the total compressor and chiller design including:

- Motor efficiency
- Refrigerant type
- Condenser and evaporator surfaces
- Compressor mechanical friction
- Impeller and vane design
- Refrigerant flow passages

Of these, the least considered performance factor on actual versus theoretical performance is the refrigerant flow passages between the discharge of one impeller and the inlet to the next impeller on multi-stage machine design. The energy loss in a single passage will be greater or equal to the loss in the suction passage between the evaporator outlet and the first stage impeller inlet, depending upon the compactness of the total compressor design. Single stage impeller design can eliminate that additional loss, and provides an opportunity for maximum system efficiency.

The primary advantage to multi-stage centrifugal operation, in the pressure and volume ranges characteristic of typical air conditioning systems, is the expansion of impeller head coefficients at reduced volumetric flows or cooling loads. The McQuay backward inclined single stage impeller, combined with unique movable diffuser geometry at the impeller discharge, provides a stable operating range superior to multi-stage systems. Thus, selection of McQuay chillers permits stable unloading without surging, and at maximum efficiency, i.e. no hot gas bypass.

Optimum compressor efficiency is designed into each McQuay impeller. The McQuay designed impeller not only minimizes pressure loss at the inlet and maximizes compression efficiency, but also breaks up pure tone sound to operate at competitively low sound power levels. A simple short diffuser and a volute design passing compressed gas directly into the condenser maintain the compressor efficiency.



**Figure 7: McQuay's million-dollar compressor test stand with advanced data acquisition provides comprehensive information on new compressor designs.**

## Bearings

Since the impeller shaft must be sized to support the static, rotational and torsional loads applied by the impeller, as impellers become larger, shafts must also become proportionally larger. These factors also come into play in the design or selection of a bearing. The primary criteria used in bearing design are:

1. The load-per-unit of bearing area.
2. The relative velocity of the two bearing surfaces.
3. The bearing dimensions.
4. The viscosity of the lubricating oil.

Notice that item 2 returns to the phenomenon of tip speed. Surface velocity is simply the tip speed of the inner bearing surface or shaft with respect to the outer bearing surface as illustrated in the following diagram.

**Figure 8, Bearing Loading**

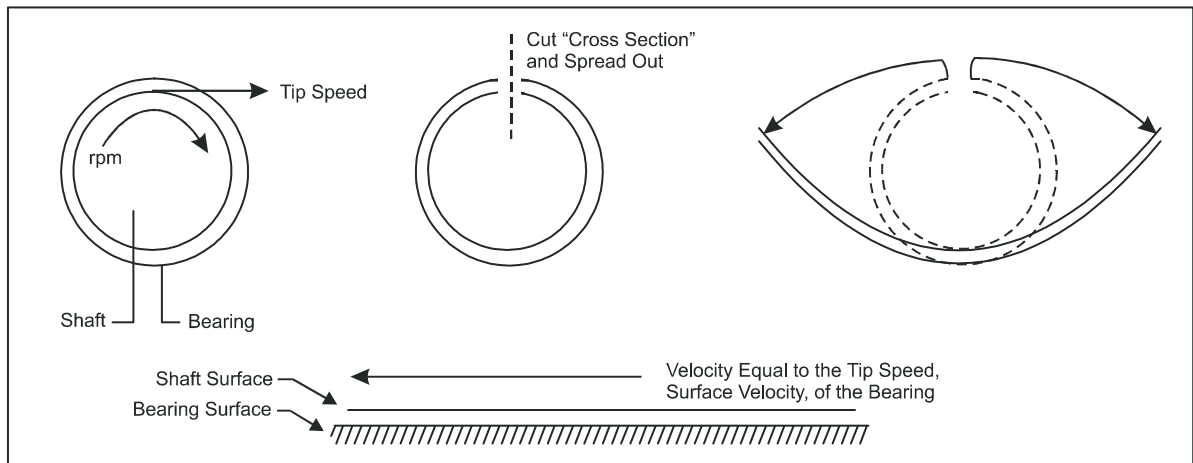

A hydrodynamic bearing is basically two infinite surfaces passing over one another with a velocity equal to the surface velocity.

Bearing design, and consequently bearing life, is determined largely by the above criteria. Rpm, by itself as an absolute, is only one half of the equation in the design process. One can also see that higher rpm and smaller, lighter parts actually reduce the load and wear on bearings.

It is the surface velocity in conjunction with the load to be supported that determines bearing life and therefore bearing selection. Referring to the analogy of the tractor trailer versus the utility trailer, one sees that even though the utility trailer tires operate at a much higher rpm, the tractor trailer wheel bearings must be much more massive due to the much heavier dynamic loading. Shaft rotating speed has little effect on bearing wear.

The smaller rotating mass of a machine will improve the life of the bearing. Before the shaft begins to spin, it rests on the bearing surface. Once the shaft starts rotating, an oil film develops between the shaft and the bearing that supports the shaft. The low mass of a positive pressure machine not only exerts a smaller static load on the bearings, but the fast spin-up enabled by the low inertia of the modern gear drive compressor permits the supportive oil film to build up more quickly.

### Liquid refrigerant injection into compressor discharge

Although this sounds complex, this feature is quite simple. Most of the noise in all centrifugal compressors results from high gas velocity in the discharge line.

The McQuay liquid injection system injects liquid refrigerant into the discharge gas through a radial array of ports. This refrigerant mist absorbs sound energy (much like a foggy day) and the flash gas cools the discharge gas leaving the compressor. The net result is significant noise reduction.



In addition, by removing superheat from the discharge gas, the condenser becomes more efficient, improving unit efficiency. Sound Levels -- One Of The Quietest Centrifugal Chillers In The Industry.

McQuay centrifugal chillers are one of the quietest units available in the marketplace due to several unique design features.

### Quiet full load sound levels and QUIETER part load sound levels

The highest noise levels for McQuay chillers are at full load. As McQuay chillers unload, noise levels reduce. Other chillers on the market are typically the opposite, with higher sound levels at part load. Be certain to compare noise levels at several load conditions.

## Moveable Discharge Geometry

Figure 9, Movable Diffuser Geometry

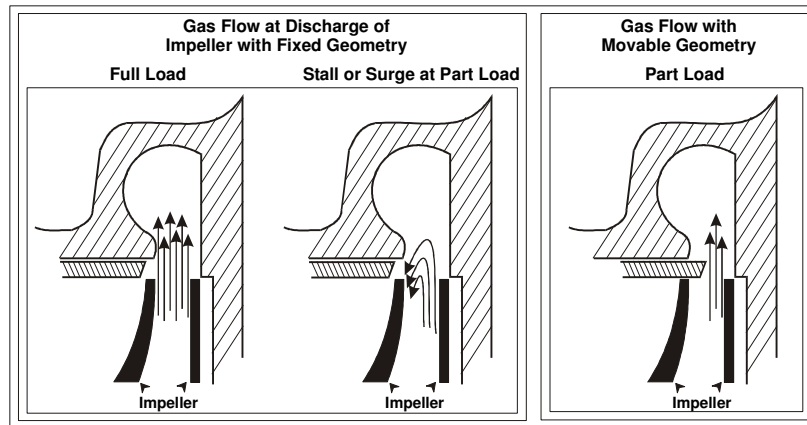

The other feature to reduce noise and increase stability at low loads is the McQuay movable discharge geometry. Less refrigerant is circulated as the chiller capacity reduces. The left drawing shows the operation at full load of a unit with a fixed compressor discharge cross section. At full load, a large quantity of gas is discharged with a fairly uniform discharge velocity as indicated by the arrows.

The middle drawing shows a fixed compressor discharge at reduced capacity. Note that the velocity is not uniform and the refrigerant tends to reenter the impeller. This is caused by low velocity in the discharge area and the high pressure in the condenser, resulting in unstable surge operation and with noise and vibration generated.

The right side drawing shows the unique McQuay movable discharge geometry. As the capacity reduces, the movable unloader piston travels inward, reducing the discharge cross section area and maintaining the refrigerant velocity. This mechanism allows our excellent unloading capacity reduction.

### Discharge Line Sound Packages

For extremely sensitive projects, an optional discharge line sound package is offered consisting of sound insulation installed on the unit's discharge line. An additional 2 to 4 dbA reduction normally occurs.

### ARI Standard 575 Sound Ratings

Sound data in accordance with ARI Standard 575 for individual units are available from your local McQuay representative. Due to the large number of component combinations and variety of applications, sound data is not included in this catalog.

## Lubrication System

A separately driven electric oil pump assembly supplies lubrication at controlled temperature and pressure to all bearing surfaces and is the source of hydraulic pressure for the capacity control system.

The control system will not allow the compressor to start until oil pressure, at the proper temperature, is established. It also allows the oil pump to operate after compressor shutdown to provide lubrication during coast-down.

Lubricant from the pump is supplied to the compressor through a water-cooled, brazed-plate heat exchanger and single or dual five-micron oil filters internal to the compressor. All bearing surfaces are pressure lubricated. Drive gears operate in a controlled lubricant mist atmosphere that efficiently cools and lubricates them.

Lubricant is made available under pressure from the compressor oil filter to the unit capacity control system and is used to position the inlet guide vanes in response to changes in leaving chiller water temperature.

If a power failure occurs, an emergency oil reservoir provides adequate lubrication flow under pressure, and prevents damage that could occur during the coast-down period with the oil pump stopped.

Since the McQuay chillers are positive pressure, there is no need to change the lubricant or filter on a regular basis. As with any equipment of this type, an annual oil check is recommended to evaluate the lubricant condition.

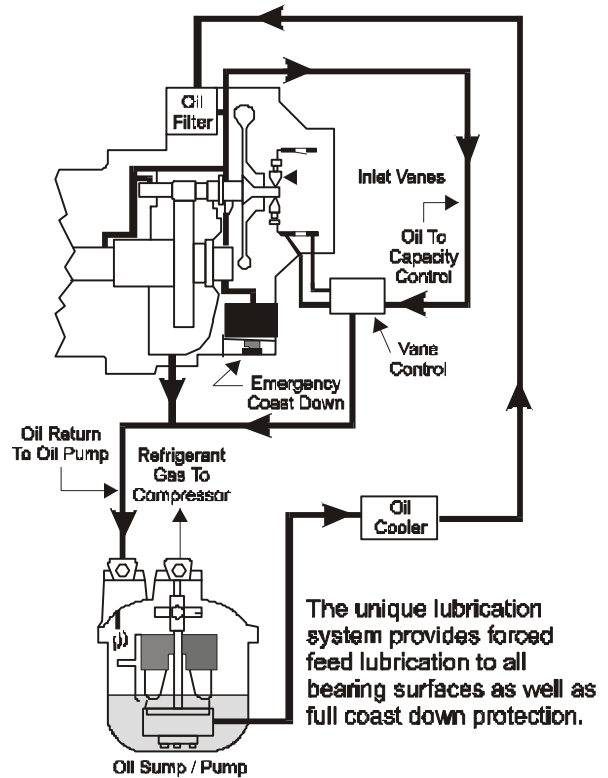

## Enhanced Surge Protection (Patent Pending)

### ESP Minimizes Compressor Stall/ Surge Damage

When centrifugal compressors operate at part load, the volume of refrigerant gas entering the impeller is reduced. At the reduced flow, the impeller's capacity to develop the peak load head is also reduced. At conditions of low refrigerant flow and high compressor head (pressure difference), stall and/or surge can occur (a stall is gas static in the impeller, a surge condition is gas rapidly reversing direction through the impeller). A number of things can contribute to this condition including inadequate maintenance of condenser tube cleanliness, a cooling tower or control malfunction, or unusual ambient temperatures among others.

For these abnormal conditions, McQuay compressor designers have developed a protective control system that senses the potential for a surge, looks at the entire chiller system operation and takes corrective action if possible; or stops the compressor, to help prevent any damage from occurring. This protection, called "ESP" is provided as standard on all McQuay centrifugal compressors.



### **A certain future for R-134a:**

The Clean Air Act of November 1990 allows the EPA to accelerate the phase-out schedule of Class I (CFC) and Class II (HCFC) refrigerants if it deems it necessary. This leaves the future of HCFCs (which includes R-22 and R-123) uncertain. R-134a will not be regulated or phased out by the Clean Air Act or the Montreal Protocol. The commercial air conditioning, home appliance, and automotive industries are just a few of the many markets that are using R-134a now and for years into the future. This large market demand for R-134a translates to a readily available and competitively priced product.

## **Compact Design**

### **Small Footprint Cuts Installation Costs**

At comparable cooling capacities, R-134a requires less than 3.2 cfm (1.5 l/sec) per ton of refrigeration to be circulated by the compressor. R-123 requires over 18.0 cfm (8.5 l/sec) per ton. The substantial increase in refrigerant volume requires significantly larger suction piping and compressor components in negative pressure designs to maintain reasonable gas velocity, noise levels and refrigerant pressure losses.

Conversely, the small physical size of McQuay centrifugal chillers will:

- Permit design of smaller equipment rooms.
- Cost less to rig and install.
- Lower joint surface area for lower likelihood of leaks.
- In smaller capacities, allow transit through standard equipment room doors, permitting building construction to proceed on schedule before receipt of the chiller equipment.

## **Heat Exchangers**

McQuay packaged centrifugal chillers are equipped with new high performance heat exchangers. The unique design greatly increases heat transfer and reduces unit footprint and refrigerant charge compared to previous designs. In many cases vessel length has been reduced by 40 percent. Chillers are designed, constructed and tested in accordance with ASME Section VIII, ASHRAE Standard 15 requirements and TEMA recommendations.

The replaceable water tubes are internally rifled and externally enhanced copper and are mechanically bonded to steel tube sheets. Standard tubes are 0.025-inch wall thickness. Consult factory for other tubing options. Optional tubes include 0.028 inch and 0.035-inch wall thickness on either vessels and 90/10 cupro-nickel, 304 stainless steel or titanium material. Clad tube sheets and epoxy-coated heads can be provided.

Vessels are available for 1, 2 or 3-pass water flow, except model WCC, which is single pass only. A ¾-inch or 1½-inch thick, flexible foam insulation is a factory installed optional. With either of these options, all seams are glued to form an effective vapor barrier and the entire chiller barrel, including non-connection heads and tube sheets, compressor suction line, and motor barrel, are insulated. Detailed information on the insulation can be found in the “Physical Data” section of this catalog.

# Retrofit Disassembly

It is estimated that fifty percent of retrofit applications require partial or complete disassembly of the chiller. On WSC chillers, McQuay offers two solutions to this problem to best fit job conditions. Contact local McQuay Factory Service for price quotation and scheduling.

**On-site disassembly**-The major components; evaporator, condenser, and compressor, are shipped fully assembled and charged and can be taken apart at the site to facilitate difficult rigging work. The chillers are shipped assembled from the factory after testing, and then disassembled and reassembled on site under supervision of authorized McQuay service personnel. Contact local McQuay Factory Service for price quotation and scheduling. Individual component weights are shown in the Physical Data section of this catalog.

**Shipped disassembled**-Chillers can be shipped knocked down from the factory. The evaporator, condenser and oil pump are shipped bolted together and easily unbolted at the job site into the pieces shown below. Other options, such as shipping less compressor or less compressor and control panel are also available. Contact local McQuay Factory Service for price quotation and scheduling.

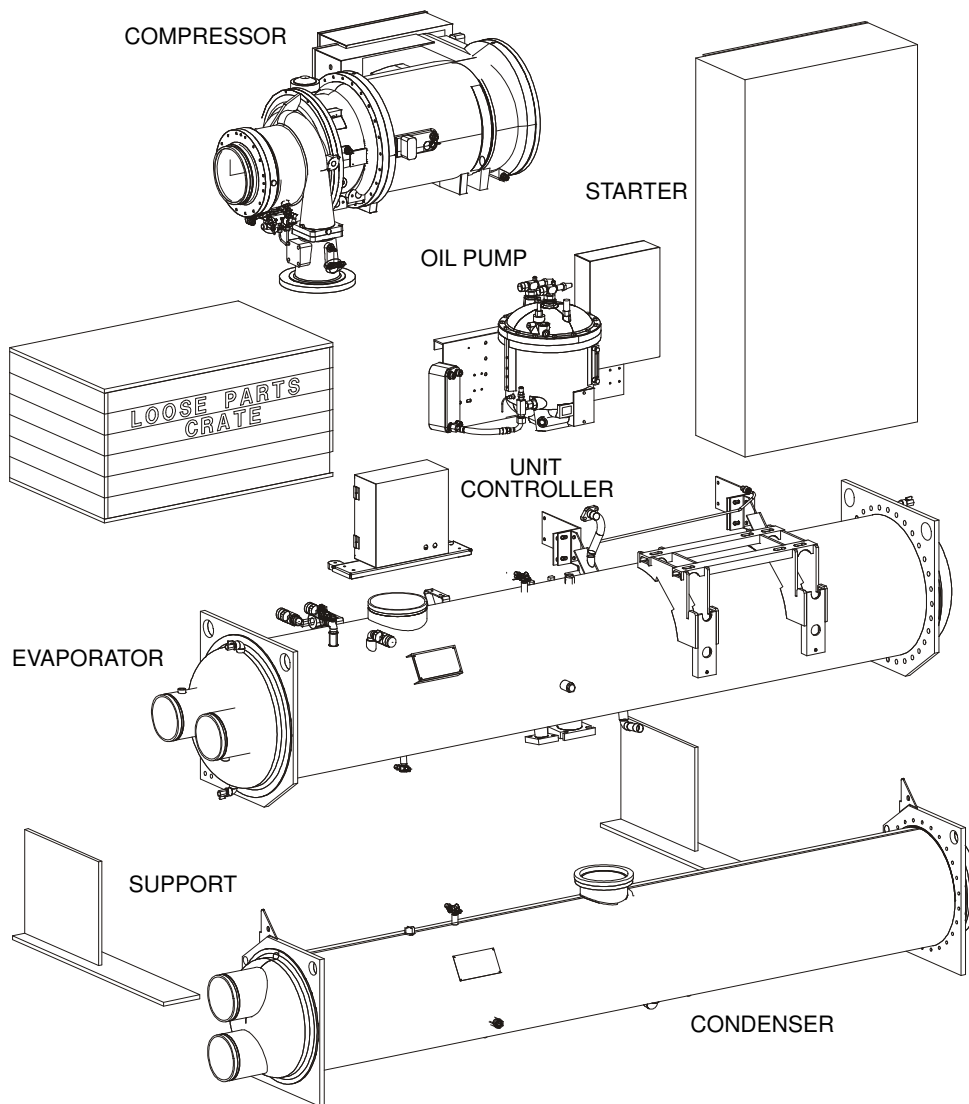

**TYPE I ...** McQuay provides ease of installation without requiring construction alterations of entryways to your building. The compressor and compressor control box are removed and put on a skid. All associated wiring and piping will remain attached if possible. The remaining loose parts will be packaged in a separate crate.

- A. Blockoffs will cover all openings on the compressor and vessels.
- B. The compressor and vessels will receive a helium holding charge.
- C. The compressor will not be insulated at the factory. An insulation kit will be shipped with the unit.
- D. The starter will ship loose. Bracket and cable kit to be included for unit-mounted starters and/or cableway for mini-cabinet.
- E. The evaporator will be insulated at the factory.
- F. Refrigerant will not be shipped with the unit and must be secured locally and furnished and installed by the installer.
- G. Oil will be shipped in containers from the factory for field installation.
- H. All field-piping connections will be Victaulic, o-ring face seal or copper brazing.
- I. All free piping ends will be capped.
- J. Touch-up paint will be included.
- K. The unit will undergo the rigorous, full McQuay test program at the factory.
- L. Contact local McQuay Factory Service for price quotation and scheduling.

**TYPE II ...** For those really tight installations, McQuay provides a total knockdown of the unit, allowing entry to the chiller site using already existing entryways. Compressor and terminal box are removed and put on a skid. The condenser, evaporator, and oil pump and supports will remain connected only by the attachment bolts for easy disassembly at the job site or riggers. All wiring and piping that interconnects the components will be removed. The remaining loose parts will be packaged in a separate crate.

- A. Blockoffs will cover all openings on the compressor and vessels.
- B. The compressor and vessels will receive a helium holding charge.
- C. The compressor will not be insulated at the factory. An insulation kit will be shipped with the unit.
- D. Only the evaporator shell will be factory insulated. Loose insulation will be shipped for the remaining surface areas.
- E. The starter will ship loose. Bracket and cable kit to be included for all unit-mounted starters and/or cableway for mini-cabinet.
- F. Refrigerant will be field supplied.
- G. All field piping connections will be Victaulic, o-ring face seal or copper brazing.
- H. All free piping ends will be capped.
- I. Touch-up paint will be included.
- J. A bolted bracket instead of a weld will mount the oil pump.
- K. The discharge piping assembly will have a bolted flange connection at the condenser. This assembly will be shipped loose.
- L. Piping that is attached to a component will be supported if it is not rigid.
- M. All pressure vessels receive the full ASME testing. The compressor and oil pump are pressure checked and run tested. The chiller will require field leak testing after assembly at its final location.
- N. Contact local McQuay Factory Service for price quotation and scheduling.

**Type III ...** The units are shipped fully assembled, factory charged, run-tested, insulated and painted. Included are the vessel bolt-on connection brackets, discharge line bolt-on flanges at the condenser and bolt-on oil pump assembly. Site disassembly and reassembly must be supervised by McQuay startup personnel. Contact local McQuay Factory Service for price quotation and scheduling.

**Table 2, Type I Knockdown Dimensions & Weights**

UNIT SIZE	VESSEL CODE	UNIT WIDTH	UNIT HEIGHT	COMPRESSOR		COMPRESSOR WEIGHT	SHIPPING WEIGHT w/o COMPRESSOR
				WIDTH	HEIGHT		
063	E2009 / C1809	57.1 (1450.6)	61.6 (1564.4)	44.0 (1118.6)	25.1 (638.3)	3200 (1452)	5212 (2366)
063	E2209 / C2009	57.1 (1450.6)	64.0 (1624.8)	44.0 (1118.6)	25.1 (638.3)	3200 (1452)	5919 (2687)
063	E2209 / C2209	57.1 (1450.6)	64.0 (1624.8)	44.0 (1118.6)	25.1 (638.3)	3200 (1452)	6216 (2882)
063	E2609 / C2209	57.1 (1450.6)	67.5 (1715.0)	44.0 (1118.6)	25.1 (638.3)	3200 (1452)	7048 (3200)
063	E2609 / C2609	57.1 (1450.6)	73.1 (1857.8)	44.0 (1118.6)	25.1 (638.3)	3200 (1452)	7784 (3534)
063	E3009 / C2609	56.8 (1441.7)	75.7 (1922.0)	44.0 (1118.6)	25.1 (638.3)	3200 (1452)	9692 (4400)
063	E2012 / C1812	57.1 (1450.6)	61.6 (1564.4)	44.0 (1118.6)	25.1 (638.3)	3200 (1452)	6084 (2762)
063	E2212 / C2012	57.1 (1450.6)	64.0 (1624.8)	44.0 (1118.6)	25.1 (638.3)	3200 (1452)	6982 (3170)
063	E2212 / C2212	57.1 (1450.6)	64.0 (1624.8)	44.0 (1118.6)	25.1 (638.3)	3200 (1452)	7357 (3340)
063	E2612 / C2212	57.1 (1450.6)	67.5 (1715.0)	44.0 (1118.6)	25.1 (638.3)	3200 (1452)	8377 (3803)
063	E2612 / C2612	57.1 (1450.6)	73.1 (1857.8)	44.0 (1118.6)	25.1 (638.3)	3200 (1452)	9294 (4219)
063	E3012 / C2612	56.8 (1441.7)	75.7 (1922.0)	44.0 (1118.6)	25.1 (638.3)	3200 (1452)	10703 (4859)
079	E2209 / C2209	50.2 (1274.6)	62.3 (1581.7)	43.6 (1108.2)	25.1 (638.3)	3200 (1452)	6940 (3151)
079	E2609 / C2209	52.7 (1338.3)	63.9 (1622.8)	43.6 (1108.2)	25.1 (638.3)	3200 (1452)	7780 (3532)
079	E2609 / C2609	52.7 (1338.3)	69.5 (1765.6)	43.6 (1108.2)	25.1 (638.3)	3200 (1452)	8516 (3866)
079	E3009 / C2609	57.1 (1449.8)	74.0 (1878.6)	43.6 (1108.2)	25.1 (638.3)	3200 (1452)	9692 (4400)
079	E3009 / C3009	59.0 (1499.4)	79.4 (2016.8)	43.6 (1108.2)	25.1 (638.3)	3200 (1452)	10876 (4938)
079	E3609 / C3009	74.7 (1896.1)	78.8 (2001.0)	43.6 (1108.2)	25.1 (638.3)	3200 (1452)	12713 (5772)
079	E2212 / C2212	50.2 (1274.6)	62.3 (1581.7)	43.6 (1108.2)	25.1 (638.3)	3200 (1452)	8081 (3669)
079	E2612 / C2212	52.7 (1338.3)	63.9 (1622.8)	43.6 (1108.2)	25.1 (638.3)	3200 (1452)	9109 (4135)
079	E2612 / C2612	52.7 (1338.3)	69.5 (1765.6)	43.6 (1108.2)	25.1 (638.3)	3200 (1452)	10026 (4552)
079	E3012 / C2612	57.1 (1449.8)	74.0 (1878.6)	43.6 (1108.2)	25.1 (638.3)	3200 (1452)	11435 (5191)
079	E3012 / C3012	59.0 (1499.4)	79.4 (2016.8)	43.6 (1108.2)	25.1 (638.3)	3200 (1452)	12919 (5865)
079	E3612 / C3012	74.7 (1896.1)	78.8 (2001.0)	43.6 (1108.2)	25.1 (638.3)	3200 (1452)	15140 (6874)
087	E2609 / C2209	52.7 (1338.3)	65.2 (1656.3)	43.6 (1108.2)	25.1 (638.3)	3200 (1452)	7780 (3532)
087	E2609 / C2609	52.7 (1338.3)	70.8 (1799.1)	43.6 (1108.2)	25.1 (638.3)	3200 (1452)	8516 (3866)
087	E3009 / C2609	57.1 (1449.8)	68.8 (1746.5)	43.6 (1108.2)	25.1 (638.3)	3200 (1452)	9692 (4400)
087	E3009 / C3009	59.5 (1510.5)	78.7 (1998.0)	43.6 (1108.2)	25.1 (638.3)	3200 (1452)	10876 (4938)
087	E3609 / C3009	74.7 (1896.1)	78.8 (2001.0)	43.6 (1108.2)	25.1 (638.3)	3200 (1452)	12713 (5772)
087	E2612 / C2212	52.7 (1338.3)	65.2 (1656.3)	43.6 (1108.2)	25.1 (638.3)	3200 (1452)	9109 (4135)
087	E2612 / C2612	52.7 (1338.3)	70.8 (1799.1)	43.6 (1108.2)	25.1 (638.3)	3200 (1452)	10029 (4553)
087	E3012 / C2612	57.1 (1449.8)	68.8 (1746.5)	43.6 (1108.2)	25.1 (638.3)	3200 (1452)	11435 (5191)
087	E3012 / C3012	59.5 (1510.5)	78.7 (1998.0)	43.6 (1108.2)	25.1 (638.3)	3200 (1452)	12918 (5865)
087	E3612 / C3012	74.7 (1896.1)	78.8 (2001.0)	43.6 (1108.2)	25.1 (638.3)	3200 (1452)	15139 (6873)
087	E3612 / C3612	80.7 (2049.3)	89.2 (2264.4)	43.6 (1108.2)	25.1 (638.3)	3200 (1452)	17384 (7892)
087*	E3612 / C3012	74.7 (1896.1)	78.8 (2001.0)	43.6 (1108.2)	25.1 (638.3)	3200 (1452)	14929 (6778)
087*	E3612 / C3612	80.7 (2049.3)	89.2 (2264.4)	43.6 (1108.2)	25.1 (638.3)	3200 (1452)	17384 (7797)
100	E3012 / C3012	67.4 (1712.2)	76.5 (1943.1)	44.0 (1117.9)	31.5 (800.1)	6000 (2724)	13397 (6082)
100	E3612 / C3012	77.2 (1961.6)	77.6 (1971.5)	44.0 (1117.9)	31.5 (800.1)	6000 (2724)	15587 (7076)
100	E3612 / C3612	83.2 (2114.0)	77.6 (1971.5)	44.0 (1117.9)	31.5 (800.1)	6000 (2724)	17826 (8093)
100*	E3612 / C3012	77.2 (1961.6)	77.6 (1971.5)	44.0 (1117.9)	31.5 (800.1)	6000 (2724)	15377 (6981)
100*	E3612 / C3612	83.2 (2114.0)	77.6 (1971.5)	44.0 (1117.9)	31.5 (800.1)	6000 (2724)	17616 (7998)
100	E4212 / C3612	86.2 (2190.5)	76.4 (1940.8)	44.0 (1117.9)	31.5 (800.1)	6000 (2724)	20487 (9301)
100	E4212 / C4212	92.2 (2342.9)	86.7 (2202.7)	44.0 (1117.9)	31.5 (800.1)	6000 (2724)	23298 (10577)
100	E4812 / C4212	98.2 (2495.3)	90.6 (2300.2)	44.0 (1117.9)	31.5 (800.1)	6000 (2724)	26024 (11815)
113	E3012 / C3012	67.4 (1712.2)	76.5 (1943.1)	44.0 (1117.9)	31.5 (800.1)	6000 (2724)	13397 (6082)
113	E3612 / C3012	77.2 (1961.6)	77.6 (1971.5)	44.0 (1117.9)	31.5 (800.1)	6000 (2724)	15578 (7072)
113	E3612 / C3612	83.2 (2114.0)	77.6 (1971.5)	44.0 (1117.9)	31.5 (800.1)	6000 (2724)	17826 (8093)
113*	E3612 / C3012	77.2 (1961.6)	77.6 (1971.5)	44.0 (1117.9)	31.5 (800.1)	6000 (2724)	15377 (6981)
113*	E3612 / C3612	83.2 (2114.0)	77.6 (1971.5)	44.0 (1117.9)	31.5 (800.1)	6000 (2724)	17616 (7998)
113	E4212 / C3612	86.2 (2190.5)	76.4 (1940.8)	44.0 (1117.9)	31.5 (800.1)	6000 (2724)	20457 (9287)
113	E4212 / C4212	92.2 (2342.9)	86.7 (2202.7)	44.0 (1117.9)	31.5 (800.1)	6000 (2724)	23298 (10577)
113	E4812 / C4212	98.2 (2495.3)	90.6 (2300.2)	44.0 (1117.9)	31.5 (800.1)	6000 (2724)	26024 (11815)
113	E4812 / C4812	104.2 (2647.7)	90.6 (2300.2)	44.0 (1117.9)	31.5 (800.1)	6000 (2724)	29016 (13173)
126	E3612 / C3012	77.2 (1961.6)	77.6 (1971.5)	44.0 (1117.9)	31.5 (800.1)	6000 (2724)	15680 (7119)
126	E3612 / C3612	83.2 (2114.0)	77.6 (1971.5)	44.0 (1117.9)	31.5 (800.1)	6000 (2724)	17826 (8093)
126*	E3612 / C3012	77.2 (1961.6)	77.6 (1971.5)	44.0 (1117.9)	31.5 (800.1)	6000 (2724)	15470 (7024)
126*	E3612 / C3612	83.2 (2114.0)	77.6 (1971.5)	44.0 (1117.9)	31.5 (800.1)	6000 (2724)	17616 (7998)
126	E4212 / C3612	86.2 (2190.5)	76.4 (1940.8)	44.0 (1117.9)	31.5 (800.1)	6000 (2724)	20457 (9287)
126	E4212 / C4212	92.2 (2342.9)	86.7 (2202.7)	44.0 (1117.9)	31.5 (800.1)	6000 (2724)	23298 (10577)
126	E4812 / C4212	98.2 (2495.3)	90.6 (2300.2)	44.0 (1117.9)	31.5 (800.1)	6000 (2724)	26024 (11815)
126	E4812 / C4812	104.2 (2647.7)	90.6 (2300.2)	44.0 (1117.9)	31.5 (800.1)	6000 (2724)	29016 (13173)

Notes:

1. The overall vessel length can vary depending on the specified tube length and pass arrangement. Consult the McQuay certified submittal drawings, or unit dimensions beginning on page 59 in this catalog for specific vessel lengths.
2. All dimensions shown in inches (mm); weights are shown in lbs (kg). Allow 1 inch manufacturing tolerance on all dimensions.
3. \*Applies specifically to models under 800 tons with a 2-pass configuration, copper tubing and utilizing E3612 evaporator.

**Table 3, Type II Knockdown Dimensions & Weights**

UNIT SIZE	VESSEL CODE	CONDENSER		FRONT & BACK SUPPORT		EVAPORATOR		COMPRESSOR	
		WIDTH	HEIGHT	WIDTH	HEIGHT	WIDTH	HEIGHT	WIDTH	HEIGHT
063	E2009 / C1809	31.8 (806.5)	36.8 (933.5)	8.0 (203.2)	22.9 (580.9)	34.6 (877.8)	28.8 (731.3)	44.0 (1118.6)	25.1 (638.3)
063	E2209 / C2009	30.5 (774.2)	36.8 (933.5)	8.0 (203.2)	22.9 (580.9)	34.6 (877.8)	35.4 (899.9)	44.0 (1118.6)	25.1 (638.3)
063	E2209 / C2209	30.5 (774.2)	36.8 (933.5)	8.0 (203.2)	22.1 (561.8)	34.6 (877.8)	35.4 (899.9)	44.0 (1118.6)	25.1 (638.3)
063	E2609 / C2209	30.5 (774.2)	36.8 (933.5)	8.0 (203.2)	22.1 (561.8)	39.2 (996.7)	35.9 (912.6)	44.0 (1118.6)	25.1 (638.3)
063	E2609 / C2609	36.0 (914.9)	42.3 (1073.2)	8.0 (203.2)	27.7 (704.6)	39.2 (996.7)	35.9 (912.6)	44.0 (1118.6)	25.1 (638.3)
063	E3009 / C2609	36.0 (914.9)	42.3 (1073.2)	8.0 (203.2)	27.0 (685.5)	42.6 (1081.0)	37.3 (948.4)	44.0 (1118.6)	25.1 (638.3)
063	E2012 / C1812	31.8 (806.5)	36.8 (933.5)	8.0 (203.2)	22.9 (580.9)	34.6 (877.8)	28.8 (731.3)	44.0 (1118.6)	25.1 (638.3)
063	E2212 / C2012	30.5 (774.2)	36.8 (933.5)	8.0 (203.2)	22.9 (580.9)	34.6 (877.8)	35.4 (899.9)	44.0 (1118.6)	25.1 (638.3)
063	E2212 / C2212	30.5 (774.2)	36.8 (933.5)	8.0 (203.2)	22.1 (561.8)	34.6 (877.8)	35.4 (899.9)	44.0 (1118.6)	25.1 (638.3)
063	E2612 / C2212	30.5 (774.2)	36.8 (933.5)	8.0 (203.2)	22.1 (561.8)	39.2 (996.7)	35.9 (912.6)	44.0 (1118.6)	25.1 (638.3)
063	E2612 / C2612	36.0 (914.9)	42.3 (1073.2)	8.0 (203.2)	27.7 (704.6)	39.2 (996.7)	35.9 (912.6)	44.0 (1118.6)	25.1 (638.3)
063	E3012 / C2612	36.0 (914.9)	42.3 (1073.2)	8.0 (203.2)	27.0 (685.5)	42.6 (1081.0)	37.3 (948.4)	44.0 (1118.6)	25.1 (638.3)
079	E2209 / C2209	30.5 (775.2)	33.1 (841.0)	8.0 (203.2)	20.6 (522.0)	32.8 (834.1)	31.5 (799.8)	43.6 (1108.2)	25.1 (638.3)
079	E2609 / C2209	30.5 (775.2)	35.9 (911.4)	8.0 (203.2)	20.6 (522.0)	36.7 (933.2)	33.2 (842.3)	43.6 (1108.2)	25.1 (638.3)
079	E2609 / C2609	30.5 (775.2)	39.3 (997.0)	8.0 (203.2)	26.2 (665.0)	36.7 (933.2)	33.2 (842.3)	43.6 (1108.2)	25.1 (638.3)
079	E3009 / C2609	36.0 (914.9)	39.3 (997.0)	8.0 (203.2)	25.4 (645.2)	40.1 (1017.8)	37.3 (948.4)	43.6 (1108.2)	25.1 (638.3)
079	E3009 / C3009	41.4 (1052.3)	45.8 (1162.1)	8.0 (203.2)	30.9 (783.8)	42.6 (1081.0)	37.3 (948.4)	43.6 (1108.2)	25.1 (638.3)
079	E3609 / C3009	41.9 (1063.5)	45.8 (1162.1)	8.0 (203.2)	25.5 (648.7)	48.1 (1222.2)	43.7 (1109.7)	43.6 (1108.2)	25.1 (638.3)
079	E2212 / C2212	30.5 (775.2)	33.1 (841.0)	8.0 (203.2)	20.6 (522.0)	32.8 (834.1)	31.5 (799.8)	43.6 (1108.2)	25.1 (638.3)
079	E2612 / C2212	30.5 (775.2)	35.9 (911.4)	8.0 (203.2)	20.6 (522.0)	36.7 (933.2)	33.2 (842.3)	43.6 (1108.2)	25.1 (638.3)
079	E2612 / C2612	30.5 (775.2)	39.3 (997.0)	8.0 (203.2)	26.2 (665.0)	36.7 (933.2)	33.2 (842.3)	43.6 (1108.2)	25.1 (638.3)
079	E3012 / C2612	36.0 (914.9)	39.3 (997.0)	8.0 (203.2)	25.4 (645.2)	40.1 (1017.8)	37.3 (948.4)	43.6 (1108.2)	25.1 (638.3)
079	E3012 / C3012	41.4 (1052.3)	45.8 (1162.1)	8.0 (203.2)	30.9 (783.8)	42.6 (1081.0)	37.3 (948.4)	43.6 (1108.2)	25.1 (638.3)
079	E3612 / C3012	41.9 (1063.5)	45.8 (1162.1)	8.0 (203.2)	25.5 (648.7)	48.1 (1222.2)	43.7 (1109.7)	43.6 (1108.2)	25.1 (638.3)
087	E2609 / C2209	30.5 (775.2)	36.8 (933.5)	8.0 (203.2)	20.6 (522.0)	39.2 (996.7)	35.9 (912.6)	43.6 (1108.2)	25.1 (638.3)
087	E2609 / C2609	36.0 (914.9)	41.8 (1060.5)	8.0 (203.2)	26.2 (665.0)	39.2 (996.7)	35.9 (912.6)	43.6 (1108.2)	25.1 (638.3)
087	E3009 / C2609	36.0 (914.9)	41.8 (1060.5)	8.0 (203.2)	25.4 (645.2)	42.6 (1081.3)	37.3 (948.4)	43.6 (1108.2)	25.1 (638.3)
087	E3009 / C3009	41.9 (1063.5)	45.8 (1162.1)	8.0 (203.2)	30.9 (783.8)	42.6 (1081.3)	37.3 (948.4)	43.6 (1108.2)	25.1 (638.3)
087	E3609 / C3009	41.9 (1063.5)	45.8 (1162.1)	8.0 (203.2)	25.5 (648.7)	48.1 (1222.2)	43.7 (1109.7)	43.6 (1108.2)	25.1 (638.3)
087	E2612 / C2212	30.5 (775.2)	36.8 (933.5)	8.0 (203.2)	20.6 (522.0)	39.2 (996.7)	35.9 (912.6)	43.6 (1108.2)	25.1 (638.3)
087	E2612 / C2612	36.0 (914.9)	41.8 (1060.5)	8.0 (203.2)	26.2 (665.0)	39.2 (996.7)	35.9 (912.6)	43.6 (1108.2)	25.1 (638.3)
087	E3012 / C2612	36.0 (914.9)	41.8 (1060.5)	8.0 (203.2)	25.4 (645.2)	42.6 (1081.3)	37.3 (948.4)	43.6 (1108.2)	25.1 (638.3)
087	E3012 / C3012	41.9 (1063.5)	45.8 (1162.1)	8.0 (203.2)	30.9 (783.8)	42.6 (1081.3)	37.3 (948.4)	43.6 (1108.2)	25.1 (638.3)
087	E3612 / C3012	41.9 (1063.5)	45.8 (1162.1)	8.0 (203.2)	25.5 (648.7)	48.1 (1222.2)	43.7 (1109.7)	43.6 (1108.2)	25.1 (638.3)
087	E3612 / C3612	46.2 (1173.2)	51.8 (1314.5)	8.0 (203.2)	35.9 (912.1)	48.1 (1222.2)	43.7 (1109.7)	43.6 (1108.2)	25.1 (638.3)
087*	E3612 / C3012	41.9 (1063.5)	45.8 (1162.1)	8.0 (203.2)	25.5 (648.7)	48.1 (1222.2)	43.7 (1109.7)	43.6 (1108.2)	25.1 (638.3)
087*	E3612 / C3612	46.2 (1173.2)	51.8 (1314.5)	8.0 (203.2)	35.9 (912.1)	48.1 (1222.2)	43.7 (1109.7)	43.6 (1108.2)	25.1 (638.3)
100	E3012 / C3012	41.0 (1041.9)	46.2 (1172.7)	8.0 (203.2)	28.6 (725.4)	48.4 (1229.6)	38.4 (974.6)	44.0 (1117.9)	31.5 (800.1)
100	E3612 / C3012	41.0 (1041.9)	46.2 (1172.7)	8.0 (203.2)	24.4 (619.5)	52.1 (1324.1)	44.1 (1120.6)	44.0 (1117.9)	31.5 (800.1)
100	E3612 / C3612	45.3 (1151.4)	52.1 (1322.3)	8.0 (203.2)	24.4 (619.5)	52.1 (1324.1)	44.1 (1120.6)	44.0 (1117.9)	31.5 (800.1)
100*	E3612 / C3012	41.0 (1041.9)	46.2 (1172.7)	8.0 (203.2)	24.4 (619.5)	52.1 (1324.1)	44.1 (1120.6)	44.0 (1117.9)	31.5 (800.1)
100*	E3612 / C3612	45.3 (1151.4)	52.1 (1322.3)	8.0 (203.2)	24.4 (619.5)	52.1 (1324.1)	44.1 (1120.6)	44.0 (1117.9)	31.5 (800.1)
100	E4212 / C3612	45.3 (1151.4)	52.1 (1322.3)	8.0 (203.2)	18.6 (473.5)	54.4 (1382.5)	51.5 (1307.6)	44.0 (1117.9)	31.5 (800.1)
100	E4212 / C4212	49.6 (1260.1)	57.6 (1462.0)	8.0 (203.2)	21.4 (543.3)	54.4 (1382.5)	51.5 (1307.6)	44.0 (1117.9)	31.5 (800.1)
100	E4812 / C4212	49.6 (1260.1)	57.6 (1462.0)	8.0 (203.2)	19.6 (498.9)	60.1 (1527.0)	57.1 (1449.6)	44.0 (1117.9)	31.5 (800.1)
113	E3012 / C3012	41.0 (1041.9)	46.2 (1172.7)	8.0 (203.2)	28.6 (725.4)	48.4 (1229.6)	38.4 (974.6)	44.0 (1117.9)	31.5 (800.1)
113	E3612 / C3012	41.0 (1041.9)	46.2 (1172.7)	8.0 (203.2)	24.4 (619.5)	52.1 (1324.1)	44.1 (1120.6)	44.0 (1117.9)	31.5 (800.1)
113	E3612 / C3612	45.3 (1151.4)	52.1 (1322.3)	8.0 (203.2)	24.4 (619.5)	52.1 (1324.1)	44.1 (1120.6)	44.0 (1117.9)	31.5 (800.1)
113*	E3612 / C3012	41.0 (1041.9)	46.2 (1172.7)	8.0 (203.2)	24.4 (619.5)	52.1 (1324.1)	44.1 (1120.6)	44.0 (1117.9)	31.5 (800.1)
113*	E3612 / C3612	45.3 (1151.4)	52.1 (1322.3)	8.0 (203.2)	24.4 (619.5)	52.1 (1324.1)	44.1 (1120.6)	44.0 (1117.9)	31.5 (800.1)
113	E4212 / C3612	45.3 (1151.4)	52.1 (1322.3)	8.0 (203.2)	18.6 (473.5)	54.4 (1382.5)	51.5 (1307.6)	44.0 (1117.9)	31.5 (800.1)
113	E4212 / C4212	49.6 (1260.1)	57.6 (1462.0)	8.0 (203.2)	21.4 (543.3)	54.4 (1382.5)	51.5 (1307.6)	44.0 (1117.9)	31.5 (800.1)
113	E4812 / C4212	49.6 (1260.1)	57.6 (1462.0)	8.0 (203.2)	19.6 (498.9)	60.1 (1527.0)	57.1 (1449.6)	44.0 (1117.9)	31.5 (800.1)
113	E4812 / C4812	53.9 (1369.1)	63.5 (1612.9)	8.0 (203.2)	19.6 (498.9)	60.1 (1527.0)	57.1 (1449.6)	44.0 (1117.9)	31.5 (800.1)
126	E3612 / C3012	41.0 (1041.9)	46.2 (1172.7)	8.0 (203.2)	24.4 (619.5)	52.1 (1324.1)	44.1 (1120.6)	44.0 (1117.9)	31.5 (800.1)
126	E3612 / C3612	45.3 (1151.4)	52.1 (1322.3)	8.0 (203.2)	24.4 (619.5)	52.1 (1324.1)	44.1 (1120.6)	44.0 (1117.9)	31.5 (800.1)
126*	E3612 / C3012	41.0 (1041.9)	46.2 (1172.7)	8.0 (203.2)	24.4 (619.5)	52.1 (1324.1)	44.1 (1120.6)	44.0 (1117.9)	31.5 (800.1)
126*	E3612 / C3612	45.3 (1151.4)	52.1 (1322.3)	8.0 (203.2)	24.4 (619.5)	52.1 (1324.1)	44.1 (1120.6)	44.0 (1117.9)	31.5 (800.1)
126	E4212 / C3612	45.3 (1151.4)	52.1 (1322.3)	8.0 (203.2)	18.6 (473.5)	54.4 (1382.5)	51.5 (1307.6)	44.0 (1117.9)	31.5 (800.1)
126	E4212 / C4212	49.6 (1260.1)	57.6 (1462.0)	8.0 (203.2)	21.4 (543.3)	54.4 (1382.5)	51.5 (1307.6)	44.0 (1117.9)	31.5 (800.1)
126	E4812 / C4212	49.6 (1260.1)	57.6 (1462.0)	8.0 (203.2)	19.6 (498.9)	60.1 (1527.0)	57.1 (1449.6)	44.0 (1117.9)	31.5 (800.1)
126	E4812 / C4812	53.9 (1369.1)	63.5 (1612.9)	8.0 (203.2)	19.6 (498.9)	60.1 (1527.0)	57.1 (1449.6)	44.0 (1117.9)	31.5 (800.1)

Notes:

1. The overall vessel length can vary. Consult the McQuay certified submittal drawings for specific vessel lengths.
2. The oil pump width is the dimension from front to back. The height is from the bottom of the sump to the top of the control box located to the right of the sump. Transporting the oil pump is usually not an issue when compared to the vessels.
3. \*Applies specifically to models under 800 tons with a 2-pass configuration, copper tubing and utilizing E3612 evaporator.
4. All dimensions shown in inches (mm); weights are shown in lbs (kg). Allow 1 inch manufacturing tolerance on all dimensions.



**Type II Table Continued**

UNIT SIZE	VESSEL CODE	OIL PUMP		CONDENSER WEIGHT	EVAPORATOR WEIGHT	COMPRESSOR WEIGHT	UNIT SHIPPING WEIGHT
		WIDTH	HEIGHT				
063	E2009 / C1809	20.8 (528.1)	30.6 (778.0)	1835 (831)	2543 (1152)	3200 (1440)	9612 (4360)
063	E2209 / C2009	20.8 (528.1)	30.6 (778.0)	2230 (1010)	2708 (1227)	3200 (1440)	10319 (4681)
063	E2209 / C2209	20.8 (528.1)	30.6 (778.0)	2511 (1137)	2708 (1227)	3200 (1440)	10616 (4815)
063	E2609 / C2209	20.8 (528.1)	30.6 (778.0)	2511 (1137)	3381 (1532)	3200 (1440)	11448 (5193)
063	E2609 / C2609	20.8 (528.1)	30.6 (778.0)	3210 (1454)	3381 (1532)	3200 (1440)	12184 (5527)
063	E3009 / C2609	20.8 (528.1)	30.6 (778.0)	3210 (1454)	4397 (1992)	3200 (1440)	14092 (6392)
063	E2012 / C1812	20.8 (528.1)	30.6 (778.0)	2183 (989)	2862 (1296)	3200 (1440)	10484 (4756)
063	E2212 / C2012	20.8 (528.1)	30.6 (778.0)	2677 (1213)	3071 (1391)	3200 (1440)	11382 (5163)
063	E2212 / C2212	20.8 (528.1)	30.6 (778.0)	3031 (1373)	3071 (1391)	3200 (1440)	11757 (5333)
063	E2612 / C2212	20.8 (528.1)	30.6 (778.0)	3031 (1373)	3880 (1758)	3200 (1440)	12777 (5796)
063	E2612 / C2612	20.8 (528.1)	30.6 (778.0)	3900 (1767)	3880 (1758)	3200 (1440)	13694 (6203)
063	E3012 / C2612	20.8 (528.1)	30.6 (778.0)	3900 (1767)	5075 (2299)	3200 (1440)	15103 (6851)
079	E2209 / C2209	18.8 (476.5)	29.1 (739.6)	2511 (1137)	2708 (1227)	3200 (1440)	11340 (5144)
079	E2609 / C2209	18.8 (476.5)	29.1 (739.6)	2511 (1137)	3381 (1532)	3200 (1440)	12180 (5525)
079	E2609 / C2609	18.8 (476.5)	29.1 (739.6)	3210 (1454)	3381 (1532)	3200 (1440)	12916 (5859)
079	E3009 / C2609	18.8 (476.5)	29.1 (739.6)	3210 (1454)	4397 (1992)	3200 (1440)	14092 (6392)
079	E3009 / C3009	18.8 (476.5)	29.1 (739.6)	4356 (1973)	4397 (1992)	3200 (1440)	15276 (6929)
079	E3609 / C3009	19.8 (501.9)	26.7 (678.9)	4356 (1973)	5882 (2665)	3200 (1440)	17113 (7762)
079	E2212 / C2212	18.8 (476.5)	29.1 (739.6)	3031 (1373)	3071 (1391)	3200 (1440)	12481 (5661)
079	E2612 / C2212	18.8 (476.5)	29.1 (739.6)	3031 (1373)	3880 (1758)	3200 (1440)	13509 (6128)
079	E2612 / C2612	18.8 (476.5)	29.1 (739.6)	3900 (1767)	3880 (1758)	3200 (1440)	14426 (6544)
079	E3012 / C2612	18.8 (476.5)	29.1 (739.6)	3900 (1767)	5075 (2299)	3200 (1440)	15835 (7183)
079	E3012 / C3012	18.8 (476.5)	29.1 (739.6)	5333 (2416)	5075 (2299)	3200 (1440)	17319 (7856)
079	E3612 / C3012	19.8 (501.9)	26.7 (678.9)	5333 (2416)	6840 (3099)	3200 (1440)	19539 (8863)
087	E2609 / C2209	19.8 (501.9)	26.7 (678.9)	2511 (1137)	3381 (1532)	3200 (1440)	12180 (5525)
087	E2609 / C2609	19.8 (501.9)	26.7 (678.9)	3210 (1454)	3381 (1532)	3200 (1440)	12916 (5859)
087	E3009 / C2609	19.8 (501.9)	26.7 (678.9)	3210 (1454)	4397 (1992)	3200 (1440)	14092 (6392)
087	E3009 / C3009	19.8 (501.9)	26.7 (678.9)	4356 (1973)	4397 (1992)	3200 (1440)	15276 (6929)
087	E3609 / C3009	19.8 (501.9)	26.7 (678.9)	4356 (1973)	5882 (2665)	3200 (1440)	17113 (7762)
087	E2612 / C2212	19.8 (501.9)	26.7 (678.9)	3031 (1373)	3880 (1758)	3200 (1440)	13509 (6128)
087	E2612 / C2612	19.8 (501.9)	26.7 (678.9)	3900 (1767)	3880 (1758)	3200 (1440)	14426 (6544)
087	E3012 / C2612	19.8 (501.9)	26.7 (678.9)	3900 (1767)	5075 (2299)	3200 (1440)	15835 (7183)
087	E3012 / C3012	19.8 (501.9)	26.7 (678.9)	5333 (2416)	5075 (2299)	3200 (1440)	17318 (7855)
087	E3612 / C3012	19.8 (501.9)	26.7 (678.9)	5333 (2416)	6840 (3099)	3200 (1440)	19539 (8863)
087	E3612 / C3612	19.8 (501.9)	26.7 (678.9)	7508 (3401)	6840 (3099)	3200 (1440)	21784 (9881)
087*	E3612 / C3012	19.8 (501.9)	26.7 (678.9)	5333 (2416)	6630 (3007)	3200 (1440)	19329 (8768)
087*	E3612 / C3612	19.8 (501.9)	26.7 (678.9)	7508 (3401)	6630 (3007)	3200 (1440)	19329 (8768)
100	E3012 / C3012	19.8 (501.9)	34.8 (884.4)	5333 (2416)	5075 (2299)	6000 (2700)	20597 (9343)
100	E3612 / C3012	19.8 (501.9)	34.8 (884.4)	5333 (2416)	6840 (3099)	6000 (2700)	22778 (10332)
100	E3612 / C3612	19.8 (501.9)	34.8 (884.4)	7508 (3401)	6840 (3099)	6000 (2700)	25026 (11352)
100*	E3612 / C3012	19.8 (501.9)	34.8 (884.4)	5333 (2416)	6630 (3004)	6000 (2700)	22568 (10237)
100*	E3612 / C3612	19.8 (501.9)	34.8 (884.4)	7508 (3401)	6630 (3004)	6000 (2700)	24816 (11257)
100	E4212 / C3612	19.8 (501.9)	34.8 (884.4)	7508 (3401)	8922 (4042)	6000 (2700)	27657 (13545)
100	E4212 / C4212	19.8 (501.9)	34.8 (884.4)	10267 (4651)	8922 (4042)	6000 (2700)	30498 (13834)
100	E4812 / C4212	19.8 (501.9)	34.8 (884.4)	10267 (4651)	11125 (5040)	6000 (2700)	33224 (15070)
113	E3012 / C3012	19.8 (501.9)	34.8 (884.4)	5333 (2416)	5075 (2299)	6000 (2700)	20597 (9343)
113	E3612 / C3012	19.8 (501.9)	34.8 (884.4)	5333 (2416)	6840 (3099)	6000 (2700)	22778 (10332)
113	E3612 / C3612	19.8 (501.9)	34.8 (884.4)	7508 (3401)	6840 (3099)	6000 (2700)	25026 (11352)
113*	E3612 / C3012	19.8 (501.9)	34.8 (884.4)	5333 (2416)	6630 (3004)	6000 (2700)	22568 (10237)
113*	E3612 / C3612	19.8 (501.9)	34.8 (884.4)	7508 (3401)	6630 (3004)	6000 (2700)	24816 (11257)
113	E4212 / C3612	19.8 (501.9)	34.8 (884.4)	7508 (3401)	8922 (4042)	6000 (2700)	27657 (13545)
113	E4212 / C4212	19.8 (501.9)	34.8 (884.4)	10267 (4651)	8922 (4042)	6000 (2700)	30498 (13834)
113	E4812 / C4212	19.8 (501.9)	34.8 (884.4)	10267 (4651)	11125 (5040)	6000 (2700)	33224 (15070)
113	E4812 / C4812	19.8 (501.9)	34.8 (884.4)	13077 (5924)	11125 (5040)	6000 (2700)	36216 (16427)
126	E3612 / C3012	19.8 (501.9)	34.8 (884.4)	5333 (2416)	6840 (3099)	6000 (2700)	22880 (10378)
126	E3612 / C3612	19.8 (501.9)	34.8 (884.4)	7508 (3401)	6840 (3099)	6000 (2700)	25128 (11398)
126*	E3612 / C3012	19.8 (501.9)	34.8 (884.4)	5333 (2416)	6630 (3004)	6000 (2700)	22670 (10283)
126*	E3612 / C3612	19.8 (501.9)	34.8 (884.4)	7508 (3401)	6630 (3004)	6000 (2700)	24918 (11303)
126	E4212 / C3612	19.8 (501.9)	34.8 (884.4)	7508 (3401)	8922 (4042)	6000 (2700)	27657 (12545)

Notes:

1. The overall vessel length can vary depending on the specified tube length and pass arrangement. Consult the McQuay certified submittal drawings, or unit dimensions beginning on page 59 in this catalog for specific vessel lengths.
2. The oil pump width is the dimension from front to back. The height is from the bottom of the sump to the top of the control box located to the right of the sump. Shipping the oil pump is usually not an issue compared to the vessels.
3. \*Applies specifically to models under 800 tons with a 2-pass configuration, copper tubing and utilizing E3612 evaporator.
4. All dimensions shown in inches (mm); weights are shown in lbs (kg). Allow 1 inch manufacturing tolerance on all dimensions.

## Pumpdown

**Pumpout systems provide a means to collect and contain the refrigerant charge without loss, when access to internal chiller components is required for service.**

McQuay condensers are sized to hold the entire unit refrigerant charge when not more than 90% full at 90°F (32°C) ambient temperature. They are equipped with a tight-seating check valve at the hot gas inlet and a manual shutoff valve in the liquid outlet. These valves, coupled with the condenser design, satisfy the stringent requirements of the U.S. Department of Transportation for refrigerant shipping containers, as well as ASME vessel codes. When service is required, the refrigerant charge can be pumped down into the condenser by compressor operation and use of a refrigerant transfer unit. All dual compressor units are equipped with suction shutoff valves and can be pumped down to the evaporator. Elimination of the cost and space requirements of an external pumpout system is a major McQuay advantage.

## Refrigerant Expansion Valves

**Controlled refrigerant flow over the entire capacity range saves energy and dollars.**

Cooling loads and condenser water temperatures can change constantly. Refrigerant float valves and orifices on competitive chillers are typically selected for peak load and peak condenser water temperatures and offer only partial control of refrigerant flow at operating conditions experienced over 95% of the time.

On McQuay chillers, modern, electronic or thermal expansion valves (depending on unit size) meter refrigerant flow in direct response to load and unit conditions. In doing so, full utilization of compressor, evaporator, and condenser efficiency over the entire operating range is achieved. Intermittent refrigerant flood-back and excessive superheat characteristic of orifices and floats are greatly reduced.

## Factory Run Test

**Fast and trouble-free startup and operation.**

All McQuay chillers are factory tested on ARI certified, microprocessor controlled, test stands. The test stand microprocessors interface with the chiller MicroTech II controls, allowing monitoring of all aspects of the test stand and chiller operation.

The test procedure starts with dehydration and evacuation of the refrigerant circuit and charging with refrigerant and lubricant. This is followed by a run test at job conditions of flow and temperature. Compressors must meet a stringent 0.14 in./sec vibration limit and the entire unit must pass a moisture limit of 30ppm. The testing helps ensure correct operation prior to shipment, and allows factory calibration of chiller operating controls.

# Options and Accessories

---

## Vessels

### Marine water boxes

Provides tube access for inspection, cleaning, and removal without dismantling water piping.

### Flanges (Victaulic® connections are standard)

ANSI raised face flanges on either the evaporator or condenser. Mating flanges are by others.

### 0.028 or 0.035 in. tube wall thickness

For applications with aggressive water conditions requiring thicker tube walls.

### Cupro-nickel or titanium tube material

For use with corrosive water conditions, includes clad tube sheets and epoxy coated water heads.

### Water-side vessel construction of 300 psi (150 psi is standard)

For high-pressure water systems, typically high-rise building construction.

### Water differential pressure switches

This option provides evaporator and condenser water pressure differential switches as a factory mounted and wired option. A proof-of-flow device is mandatory in both the chilled water and condenser water systems.

### Single insulation, ¾-inch, on evaporator, suction piping, and motor barrel

For normal machine room applications.

### Double insulation, 1-½ inch, on evaporator, suction piping, and motor barrel

For high humidity locations and ice making applications.

## Electrical

### Optional starters for factory or field mounting

See details in the Motor Starter section of this manual and catalog PM Starter.

### Variable frequency drives (VFD)

The variable frequency drive option is a technology that has been used for decades to control motor speed on a wide variety of motor-drive applications. When applied to centrifugal compressor motors, significant gains in compressor part load performance can be realized. The improvement in efficiency and reduction of annual energy cost is maximized when there are long periods of part load operation, combined with low compressor lift (lower condenser water temperatures). When atmospheric conditions permit, McQuay chillers equipped with VFDs can operate with entering condenser as low as 50°F (10°C), which results in extremely low kW/ton values.

Combining the attributes of VFD drives and the extremely efficient McQuay WDC Dual Centrifugal Chiller produces the industry's most efficient chiller based on the all-important IPLV value. See "IPLV/NPLV Defined" on page 43 for details on the ARI IPLV efficiency rating.

**Water-Side Economizers:** Free cooling systems utilizing cold cooling tower water to remove heat from the chilled water system through a heat exchanger are becoming popular because the ability of a chiller to move seamlessly from mechanical cooling to the free cooling mode is an important operational feature. When equipped with a VFD, McQuay chillers can operate with condenser water down to 50°F (10°C) at which point the economizer heat exchanger can be activated and the free cooling can go into effect.

**Starting Inrush:** The use of a VFD on centrifugal chillers also provides an excellent method of reducing motor starting inrush, even better than solid-state starters. Starting current can be closely controlled since both the frequency and voltage are regulated. This can be an important benefit to a building's electrical distribution system.

**Sound:** The sound level of centrifugal compressors is largely dependent on the impeller tip speed. By reducing compressor speed the sound level is also reduced.

**NEMA 4 watertight enclosure**

For use where there is a possibility of water intrusion into the control panel.

**NEMA 12 Dust tight enclosure**

For use in dusty areas.

## Controls

**English or Metric Display**

Either English or metric units for operator ease of use.

**BAS interface module for the applicable protocol being used.**

Factory-installed on the unit controller (can also be retrofitted). See page 19 for details.

## Unit

**Export packaging**

Can be either slat or full crate for additional protection during shipment. Units normally shipped in containers.

**Pumpout Unit, Model RRU with or without storage vessel**

Available in a variety of sizes. Details under the Pumpout section on page 41 of this manual.

**Refrigerant monitor**

For remote mounting, including accessories such as 4-20ma signal, strobe light, audible horn, air pick-up filter. Details on page 41.

**Hot gas bypass**

Reduces compressor cycling and its attendant chilled water temperature swings at very low loads.

**Sound attenuation package**

Consists of acoustical insulation on the discharge line.

**Extended warranties**

Extended 1, 2, 3, or 4-year warranties for parts only or for parts and labor are available for the entire unit or compressor/motor only.

**Optional Certified Test**

A McQuay engineer oversees the testing, certifies the accuracy of the computerized results, and then translates the test data onto an easy-to-read spreadsheet. The tests can be run at ARI load points and are run to ARI tolerance of capacity and power. 50 Hz units are run tested at 60 Hz to their maximum motor power.

**Optional Witness Test**

A McQuay engineer oversees the testing in the presence of the customer or their designate and translates the test data onto an easy-to-read spreadsheet. The tests can be run at ARI load points and are run to ARI tolerance of capacity and power. Allow two to three hours of test time per load point specified. Units built for 50 Hz power can be run-tested using an onsite 50 Hz generator.

# Motor Controllers

## Motor Starters

McQuay has a wide variety of starter types and options to fit virtually all applications. The specifics of the final selection of size, enclosure, and options are covered in the catalog [Cat Starter](#). Please consult the local McQuay sales office or the starter catalog for starter details. This section contains a general overview only.

### Mounting Options, Low Voltage, 200 to 600 Volts

Factory-mounted; starters furnished, mounted and wired in the factory. Due to shipping width limitations, the starters for WSC 100 through 126 are shipped loose with cable kits and mounting brackets for field installation on the unit by others.

Freestanding; furnished by McQuay and drop shipped to the job site for setting and wiring by others.

Starters by others; starters furnished by others must meet McQuay Specification R35999901, available from the local McQuay sales office. The starters are furnished and installed by others.

Table 4, Low Voltage Starter Mounting Arrangements

Size	Factory-Mounted	Free-Standing	Brackets & Cables
WSC/WDC 063-087	X	X	
WSC/WCC 100-126		X	X
WDC 100-126		X	
WCC 100-126		X	X

### Mounting Options, Medium Voltage, 2300 to 6000 Volts

All starter types in these voltages are for field setting and wiring only.

## Starter Types and Descriptions

Solid state starters are available for both low and medium voltages and are similar in construction and features regardless of voltage. For low voltage application, Wye-Delta Closed Transition starters are available, in addition to solid state. For medium voltage application, autotransformer, primary reactor reduced voltage and across-the-line starters are offered in addition to solid state.

## Variable Frequency Drives

Single and dual compressor units can be equipped with a variable frequency drive (VFD). A VFD modulates the compressor speed in response to load and evaporator and condenser pressures as sensed by the microprocessor. Due to the outstanding part load efficiency, and despite the small power penalty attributed to the VFD, the chiller can achieve outstanding *overall* efficiency. VFDs really prove their worth when there is reduced load combined with low compressor lift (lower condenser water temperatures) dominating the operating hours.

The traditional method of controlling centrifugal compressor capacity is by inlet guide vanes. Capacity can also be reduced by slowing the compressor speed and reducing the impeller tip speed, *providing* sufficient tip speed is retained to meet the discharge pressure requirements. This method is more efficient than guide vanes by themselves.

In actual practice a combination of the two techniques is used. The microprocessor slows the compressor (to a fixed minimum percent of full load speed) as much as possible, considering the need for tip speed to make the required compressor lift. Guide vanes take over to make up the difference in required capacity reduction. This methodology provides the optimum efficiency under any operating condition.

## Impact of Variable Frequency Drives

The chart below illustrates the relative IPLV efficiencies of various McQuay options for a typical 500-ton selection. The chiller cost increases as the efficiency improves.

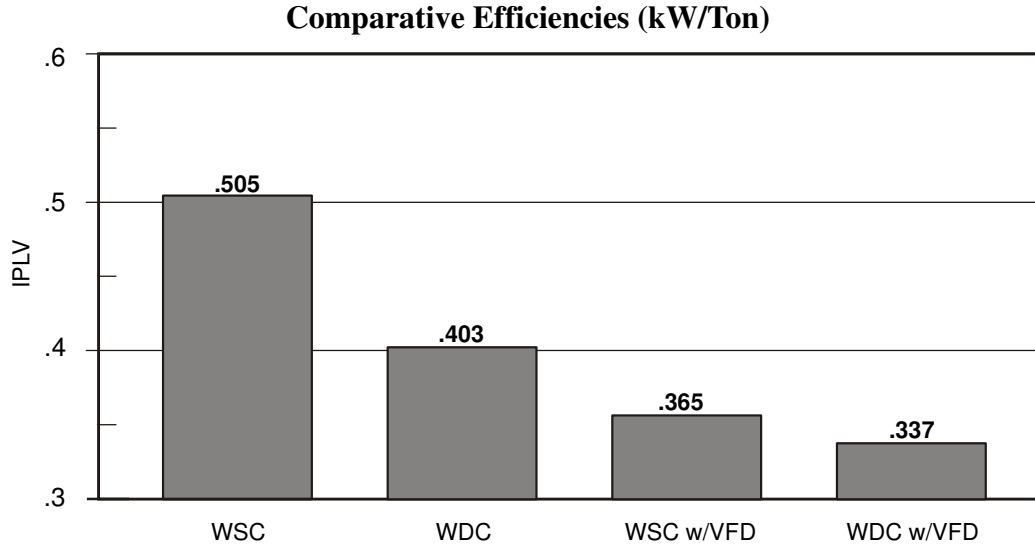

Notes: WSC = Single Compressor Centrifugal Chiller  
WDC = Dual Compressor Centrifugal Chiller  
VFD = Variable Frequency Drive

The IPLV values (defined on page 43) are ARI Certified Ratings based on ARI Standard 550/590, *Standard for Water Chilling Packages Using the Vapor Compression Cycle*. Full load is at 44°F chilled water temperature with 2.4 gpm/ton, 85°F entering condenser water temperatures with 3 gpm/ton. Part load points of 75%, 50%, and 25% employ condenser water temperature relief (reduction) per the standard.

## VFD Options

### Reactor

- Used for control of line harmonics in some installations.

### Incoming Line Termination (Choose one)

- Terminal block
- Non-fused disconnect with through-the-door handle
- Fused disconnect with time delay fuses with through-the-door handle
- Standard interrupting circuit breaker with through-the-door handle
- High interrupting circuit breaker with through-the-door handle
- Ultra high circuit breaker with through-the-door handle

### Volts/Amps Meter

- With 3-phase Switch

# General Arrangement

## VFD Mounting

VFDs from size VFD 019 through VFD 072 can be factory-mounted on the same units and in the same location as conventional starters or can be free-standing as shown below. Sizes VFD 090 through 120 are for free-standing only. Dimensions begin on page 60.

Chiller Model	Unit Mounted at Factory (1)	Unit Mounted in Field	Free-Standing (2)
WSC, WDC 063-087	X		X
WSC 100-126		X (3)	X
WDC 100-126			X
WCC 100-126		X (3)	x

### Notes:

1. Optional reactor is field-mounted and wired to unit mounted VFD.
2. Optional reactor is factory-mounted in the VFD enclosure.
3. Brackets and interconnecting cables shipped with unit.

## VFD Line Harmonics

Care must be taken when applying VFDs due to the effect of line harmonics on the electric system. VFDs cause distortion of the AC line because they are nonlinear loads; that is, they don't draw sinusoidal current from the line. They draw their current from only the peaks of the AC line, thereby flattening the top of the voltage waveform. Some other nonlinear loads are electronic ballasts and uninterruptible power supplies. Line harmonics and their associated distortion may be critical to AC drive users for three reasons:

1. Current harmonics can cause additional heating to transformers, conductors and switchgear.
2. Voltage harmonics upset the smooth voltage sinusoidal waveform.
3. High-frequency components of voltage distortion can interfere with signals transmitted on the AC line for some control systems.

The harmonics of concern are the 5<sup>th</sup>, 7<sup>th</sup>, 11<sup>th</sup>, and 13<sup>th</sup>. Even harmonics, harmonics divisible by three, and high magnitude harmonics are usually not a problem.

### Current Harmonics

An increase in reactive impedance in front of the VFD helps reduce the harmonic currents. Reactive impedance can be added in the following ways:

1. Mount the drive far from the source transformer.
2. Add line reactors.
3. Use an isolation transformer.

### Voltage Harmonics

Voltage distortion is caused by the flow of harmonic currents through a source impedance. A reduction in source impedance to the point of common coupling (PCC) will result in a reduction in voltage harmonics. This may be done in the following ways:

1. Keep the PCC as far from the drives (close to the power source) as possible.
2. Increase the size (decrease the impedance) of the source transformer.
3. Increase the capacity (decrease the impedance) of the busway or cables from the source to the PCC.
4. Make sure that added reactance is downstream (closer to the VFD than the source) from the PCC.

### The IEEE 519 Standard

The Institute of Electrical and Electronics Engineers (IEEE) has developed a standard that defines acceptable limits of system current and voltage distortion. A simple form is available from McQuay that allows McQuay to determine compliance with IEEE 519. Line reactors, isolation transformers, or phase-shifting transformers may be required on some installations.

**Figure 10, VFD (047 and Larger) Cooling Water Piping for Free-Standing VFD**

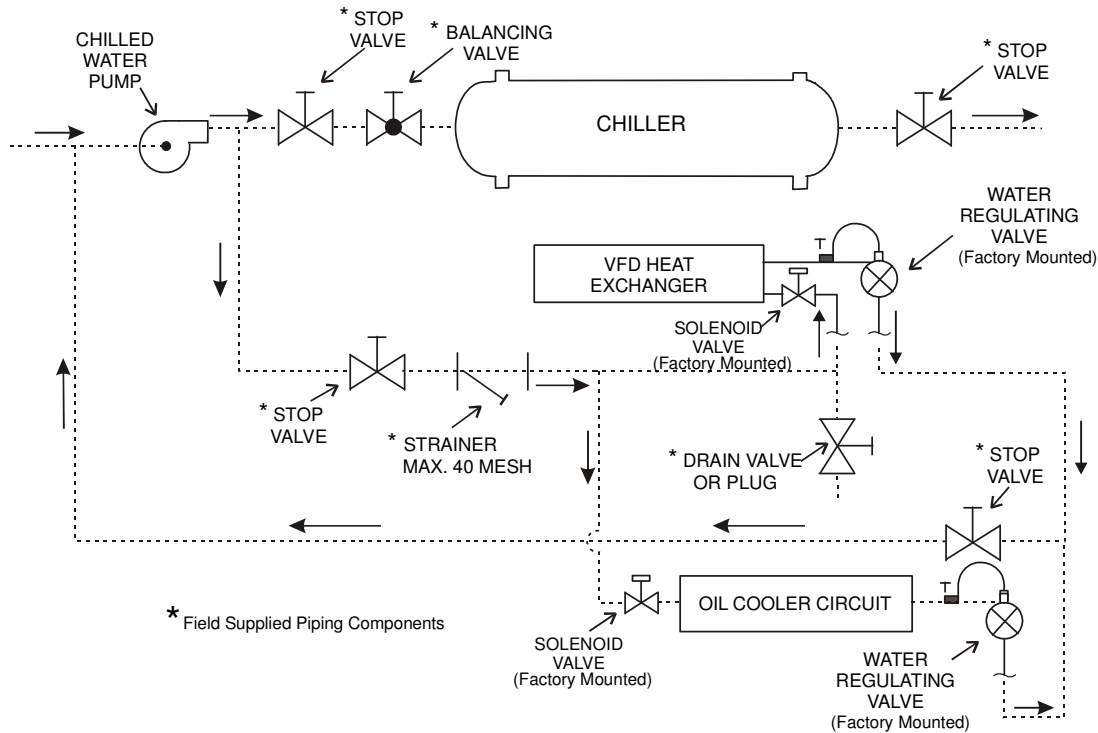

**Table 5, Cooling Requirements**

McQuay Drive Model Number	Combined Compressor Oil and VFD Cooling Copper Tube Size Type K or L	VFD Cooling Only Copper Tube Size Type K or L	Coolant Method	Max. Entering Coolant Temperature (°F)	Min. Entering Coolant Temperature (°F)	Required Pressure Drop feet	Maximum Pressure (Water Side) psi
VFD 019	N/A	N/A	Air	104	40	NA	N/A
VFD 025	N/A	N/A	Air	104	40	NA	N/A
VFD 047	1.0	7/8 in.	Water (1)	90	40	10 (2)	300
VFD 060	1.0	7/8 in.	Water (1)	90	40	30 (2)	300
VFD 072	1.0	7/8 in.	Water (1)	90	40	30 (2)	300
VFD 090	1 1/4	1.0 in.	Water (1) (3)	90	40	30 (2)	300
VFD 120	1 1/4	1.0 in.	Water (1) (3)	90	40	30 (2)	300

**Notes (next page):**

1. Cooling water must be from the closed, chilled water circuit with corrosion inhibitors for steel and copper, and must be piped across the chilled water pump.
2. The required pressure drop is given for the maximum coolant temperature. The water regulating valve will reduce the flow when the coolant temperature is below the maximum in the table. The pressure drop includes the drop across the solenoid valve, heat exchanger and water regulating valve.
3. Models VFD 090 and 120 have a separate self-contained cooling module with a recirculating water pump and heat exchanger, but are piped the same as all water-cooled VFDs.

**Table 6, Cooling Water Connection Sizes**

Chiller Unit	Free-Standing VFD		Factory-Mounted VFD
	Oil Cooler	VFD	Combined
WDC/WCC 100/126	1 1/2 in. FPT	3/4 in. MPT	1 1/2 in. FPT
All Others	1 in. FPT	3/4 in. MPT	1 in. FPT



# Refrigerant Recovery Units

Although McQuay chillers can pump the entire refrigerant charge into the condenser and valve it off, there are occasions when pumpout units are required, due purely to specification requirements or unusual job considerations. McQuay offers two sizes of refrigerant recovery units (Model RRU) and one recovery unit that is factory mounted on a storage vessel (Model PRU). Recovery units are ETL listed. Capacities for R-22 are ARI certified. The storage tank is designed, constructed and stamped in accordance with ASME standards.

## Model RRU Refrigerant Recovery Units



### Model RRU134

Large 1 ½-HP open drive compressor, ½-inch lines, two-point vapor extraction and oversized air-cooled condenser speed recovery on smaller size chillers. Purging and switching from liquid to vapor recovery only involves turning 3-way valves-no switching of hoses is necessary. Capacity with R-134a is 55 lb/min liquid, 1.34 lb/min vapor.

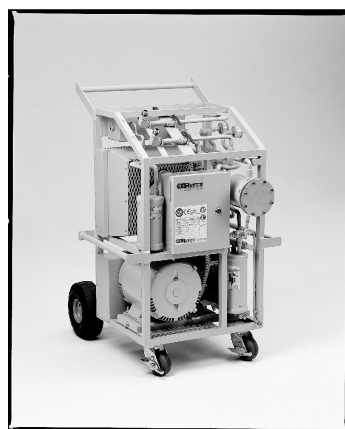

### MODEL RRU570

Recovers at R-134a at 300 lb/min liquid and 5.7 lb/min vapor, ideal for the medium size chiller job. Rugged 3 hp open-drive compressor provides years of reliable service, even on refrigerants heavily contaminated with oil, air, moisture, or acids. Purging and switching from liquid to vapor recovery only involves turning 3-way valves-no switching of hoses is necessary. Suitable for most high-pressure refrigerants and blends. Equipped with air-cooled condenser.

## Refrigerant Monitors

- Detects all halogen based refrigerants
- Optional analog output for remote monitoring
- Visual alarm indication
- Fresh air inlet for automatic re-zeroing
- ETL listed
- Continuous digital display of system status
- System malfunction detection and indication
- Can sample up to 250 feet (76 meters) away
- Multi-unit capability in a single monitor
- UL STD 3101-1 and CAN/CSA 1010.1

### MODELS

Model RM-1 – 1 Zone Monitor

Model RM-4 – 4 Zone Monitor

Model RM-8 – 8 Zone Monitor

Model RM-16 – 16 Zone Model



# Unit Selection

Many combinations of compressor configuration and condensers and evaporators are available for a given capacity. The units range from low first cost and relatively high kW per ton (COP) to high first cost and low kW per ton (COP). A graphic display of the optional performance available is shown at the right. The COP curve would be mirrored and is not shown for clarity. Optimum unit selection for maximum operating return on the invested first cost is in the area identified by the X. Actual optimum unit selection will vary with building application and system design. Applications with minimal hours of operation cannot justify a very low kW per ton (COP) unit. Applications with high hours of operation will justify high part load as well as full load efficiency units. For optimum selection an energy analysis is available through your local McQuay Sales Representative.

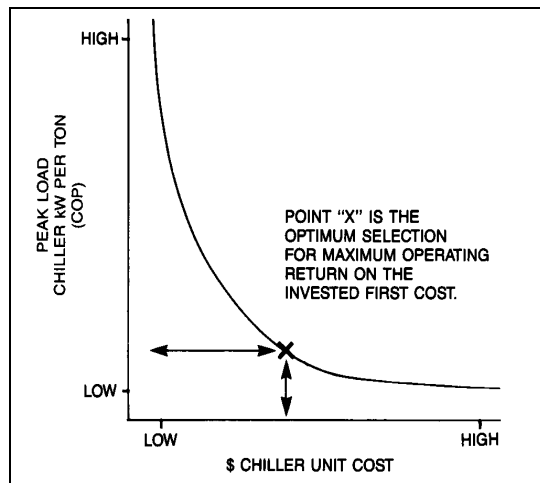

## Basic unit selections

All McQuay centrifugal chillers are computer selected to optimize the cooling output and total kW. Computer selection allows for the specification of leaving chilled water temperature, entering condenser water temperature, evaporator and condenser flow rates, number of passes, and fouling factors. Glycol applications can also be specified.

## Glycol operation

The addition of glycol to the chilled water system for freeze protection can be required for special applications. Glycol solutions are required where the evaporating temperatures are below 33°F (1°C).

## ARI Certification

McQuay International has an on-going commitment to supply chillers that perform as specified. To this extent, McQuay centrifugal chillers are part of the ARI Certification. On-going performance verification of chiller capacity and power input plus ARI certified computerized selection output provide the owner with specified performance in accordance with the latest version of ARI Standard 550/590.

All chillers that fall within the scope of the certification program have an ARI certification label at no cost to the owner. Equipment covered by the ARI certification program include all water-cooled chilling packages rated up to 2500 tons (8793 kW) ARI standard rating conditions, hermetic or open drive, with electric driven motor not exceeding 5000 volts, and cooling water (not glycol).

Published certified ratings verified through testing by ARI include:

- Capacity, tons (kW)    • Power, kW/ton (COP)    • Pressure drops, ft. of water (kPa)
- Integrated Part Load Value (IPLV) or Non-Standard Part Load Value (NPLV)

As part of the ARI certification program (see <http://www.ahrinet.org/>), ARI has the McQuay computer selection program used to select and rate chillers. The certified computer program version number and issue date for all manufacturers is listed in the ARI Directory of Certified Applied Air-Conditioning Products available on [www.ari.org](http://www.ari.org).

ARI Standard 550/590-98 for Centrifugal or Screw Water-Chilling Packages and associated manuals define certification and testing procedures and performance tolerances of all units that fall within the application rating conditions.

Leaving chilled water temperature..... 40°F to 48°F (4.4°C to 8.9°C)

Entering condenser water temperature..... 60°F to 95°F (15.6°C to 35°C)

Rating outside the range of the certification program can be listed or published but must include a statement describing such. The standard rating conditions are:



# Application Considerations

## Optimum Water Temperatures and Flow Rates

A key to improving energy efficiency for any chiller is minimizing the lift, or pressure difference, between the compressor suction and discharge pressures. Reducing the lift reduces the compressor work, and hence its energy consumption per unit of output. The chiller typically has the largest motor of any component in a chilled water system.

### Higher leaving chilled water temperatures

Warmer leaving chilled water temperatures will raise the compressor's suction pressure and decrease the lift, improving efficiency. Using 45°F (7.0°C) leaving water instead of 42°F (5.5°C) will make a significant improvement.

### Evaporator temperature drop

The industry standard has been a ten-degree temperature drop in the evaporator. Increasing the drop to 12 or 14 degrees will improve the evaporator heat transfer, raise the suction pressure, and improve chiller efficiency. Chilled water pump energy will also be reduced.

### Condenser entering water temperature

As a general rule, a one-degree drop in condenser entering water temperature will reduce chiller energy consumption by two percent. Cooler water lowers the condensing pressure and reduces compressor work. One or two degrees can make a noticeable difference. The incremental cost of a larger tower can be small and provide a good return on investment.

### Condenser water temperature rise

The industry standard of 3 gpm/ton or about a 9.5-degree delta-T works well for most applications. Reducing condenser water flow to lower pumping energy will increase the water temperature rise, resulting in an increase in the compressor's condensing pressure and energy consumption. This is usually not a productive strategy.

### System analysis

Although McQuay is a proponent of analyzing the entire system, it is generally effective to place the chiller in the most efficient mode because it is, by far, a larger energy consumer than pumps.

The McQuay Energy Analyzer™ program is an excellent tool to investigate the entire system efficiency, quickly and accurately. It is especially good at comparing different system types and operating parameters. Contact your local McQuay sales office for assistance on your particular application.

### For Best Chiller Efficiency

Vessel	Activity	Example
Evaporator	Higher leaving water Temperatures	44°F instead of 42°F
Evaporator	Higher water temperature drops	12 degrees F instead of 10 degrees
Evaporator	Lower flow rates	2.4 gpm/ton instead of 3.0 gpm/ton
Condenser	Lower entering water temperature	84°F instead of 85°F
Condenser	Higher flow rates (3.0 gpm/ton or higher)	3.0 gpm/ton instead of 2.5 gpm/ton

The designer must determine the proper chiller efficiency for a given application. The most efficient chiller is not always the best. A life cycle analysis (as performed by McQuay's Energy Analyzer program, for example) is the only way to be sure of the best selection. Utility costs, load factors, maintenance costs, cost of capital, tax bracket; in other words, all the factors affecting owning cost, must be considered.

Generally, the attempts to save the last few full load kW are very costly. For example, the cost to go from 0.58 to 0.57 kW/ton could be very costly because of the large number of copper tubes that would have to be added to the heat exchangers.

# Low Condenser Water Temperature Operation

When ambient wet bulb temperatures are lower than design, the condenser water temperature can be allowed to fall. Lower temperatures will improve chiller performance.

## Up to 600 Tons

McQuay centrifugal chillers up to 600 Tons are equipped with electronic expansion valves (EXV) and will start and run with entering condenser water temperatures as low as shown in Figure 11 or as calculated from the following equation on which the curves are based.

Figure 11, Minimum Entering Condenser Water Temperature (EXV)

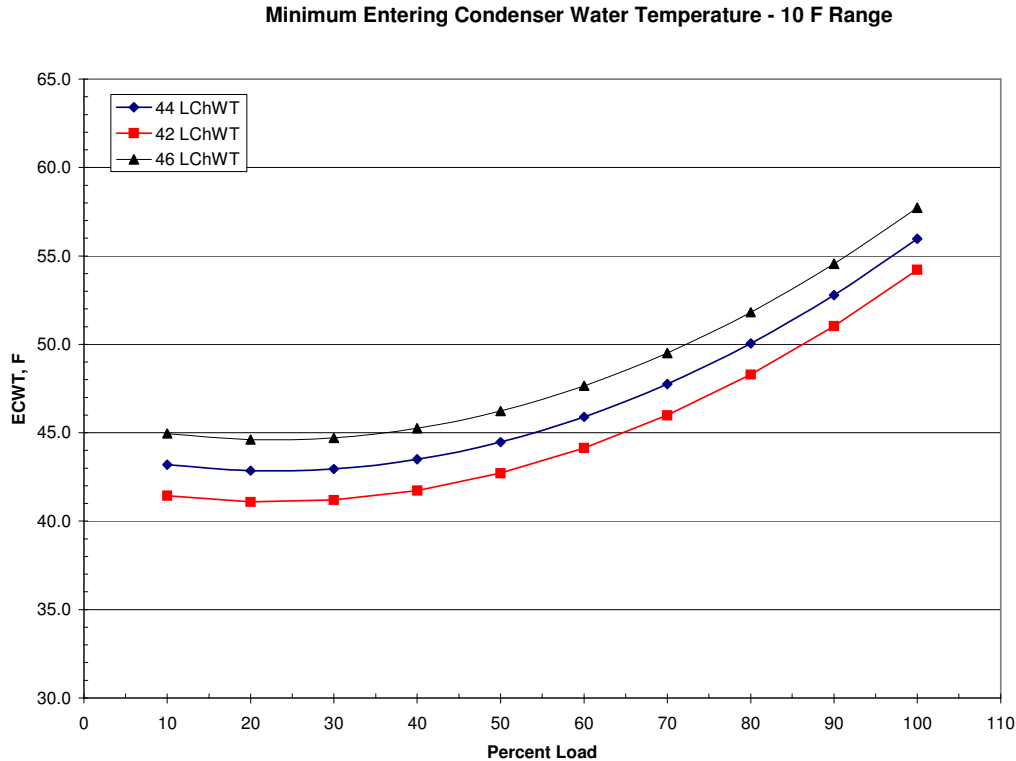

$$\text{Min. ECWT} = 5.25 + 0.88*(\text{LWT}) - \text{DT}_{\text{FL}}*(\text{PLD}/100) + 22*(\text{PLD}/100)^2$$

- ECWT = Entering condenser water temperature
- LWT = Leaving chilled water temperature
- $\text{DT}_{\text{FL}}$  = Chilled Water Delta-T at full load
- PLD = The percent chiller load point to be checked

For example; at 44°F LWT, 10 degree F Delta-T, and 50% full load operation, the entering condenser water temperature could be as low as 44.5°F. This provides excellent operation with water-side economizer systems.

## Over 600 Tons

Chillers over 600 Tons are equipped with thermal expansion valves (TXV) and will start and run with entering condenser water temperatures as low as calculated by the following equation and shown in the chart following.

$$\text{Min. ECWT} = 7.25 + \text{LWT} - 1.25* \text{DT}_{\text{FL}}(\text{PLD}/100) + 22*(\text{PLD}/100)^2$$

- ECWT = Entering condenser water temperature
- LWT = Leaving chilled water temperature
- $\text{DT}_{\text{FL}}$  = Chilled Water Delta-T at full load
- PLD = The percent chiller load point to be checked

**Figure 12, Minimum Entering Condenser Water Temperature (TXV)**

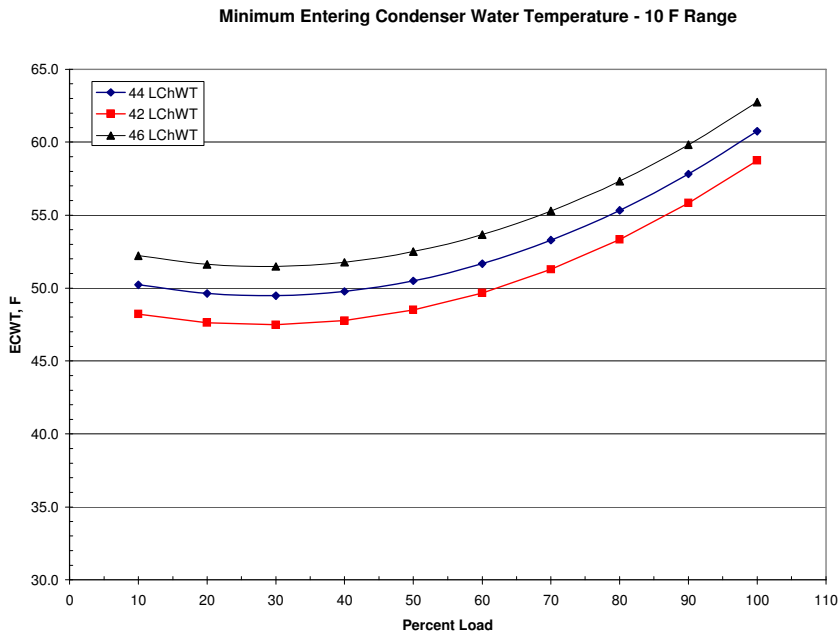

For example; at 44°F LWT, 10 degree F Delta-T, and 50% full load operation, the entering condenser water temperature could be as low as 50.5°F. This provides excellent operation with water-side economizer systems. Depending on local climatic conditions, using the lowest possible entering condenser water temperature may be more costly in total system power consumed than the expected savings in chiller power would suggest, due to the excessive fan power required.

Cooling tower fans must continue to operate at 100% capacity at low wet bulb temperatures. As chillers are selected for lower kW per ton, the cooling tower fan motor power becomes a higher percentage of the total peak load chiller power. McQuay’s Energy Analyzer program can optimize the chiller/tower operation for specific buildings in specific locales.

Even with tower fan control, some form of water flow control, such as tower bypass, is recommended.

Figure 13 illustrates two temperature actuated tower bypass arrangements. The “Cold Weather” scheme provides better startup under cold ambient air temperature conditions. The check valve may be required to prevent entraining air at the pump inlet.

**Figure 13, Bypass, Mild Weather Operation**

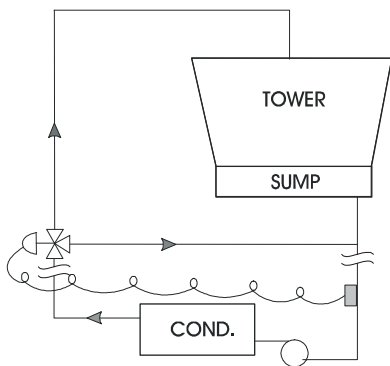

**Bypass, Cold Weather Operation**

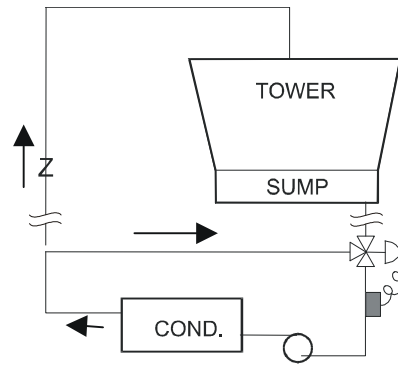

# Mixing Single and Dual Compressor Chillers

WDC dual compressor chillers excel at part load operation, while single compressor chillers usually have better full load efficiency. A good chiller plant strategy is to install one dual and one or more single compressor units. Run the dual until it is fully loaded, then switch to the single compressor unit and run it only at full load, using the dual to trim the load.

## Series Counterflow and Series Parallel Chillers

The design of piping systems can greatly impact chiller performance. A popular system is to place the evaporators in series with the chilled water flowing from one evaporator to the next as shown in Figure 14 and Figure 15. Two different condenser water piping arrangements can be used. Parallel flow (Figure 14) divides the total condenser flow between the two condensers. The counterflow system (Figure 15) puts all of the condenser water through the condenser of the lag chiller (chiller producing the coldest evaporator leaving water) and then through the lead chiller (chiller seeing the warmest evaporator water temperatures).

Typically, since the lead machine will see the warmest evaporator water, it will have the greater capacity and larger portion of the total system evaporator temperature drop. Again referring to Figure 14 and Figure 15, the lead machine has an 8.4 degree drop (56.0°F-47.6°F) and the lag machine has a 5.6 degree drop (47.6°F – 42.0°F).

Condenser water flow is important to overall system efficiency. With parallel flow (Figure 14), the condensers have identical flow conditions (95 to 85 degrees in this example) with the compressor lift shown. With counterflow arrangement the lift on the lead machine is significantly lower, reducing compressor work and making the overall system efficiency about 2% better. Even though the chiller performance is different, it is good practice to use the same chiller models.

Both the WSC and WDC chillers are suitable for series counterflow arrangement and include controls specifically designed for series chillers. For more information, please refer to Application guide AG –31-003: Chiller plant design. McQuay’s model WCC dual compressor chiller (1200 to 2700 tons) combines counterflow design into one unit. See page 9 for details.

**Figure 14, Series Parallel Flow**

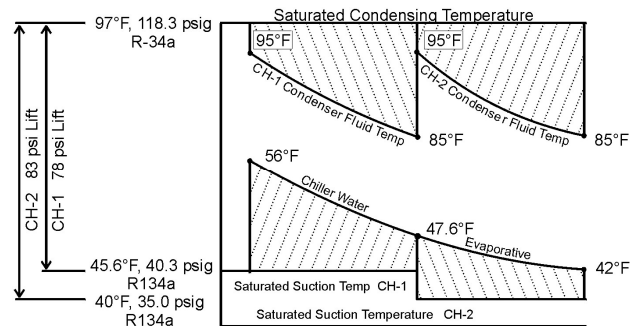
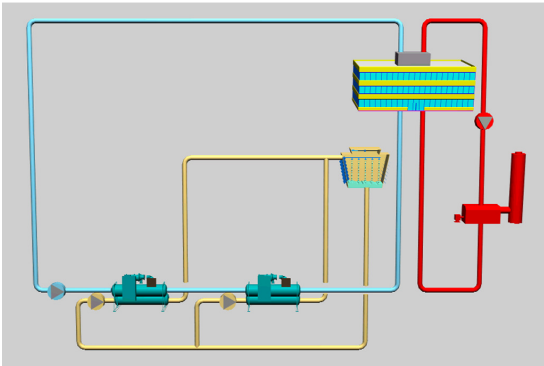

**Figure 15, Series Counterflow Flow**

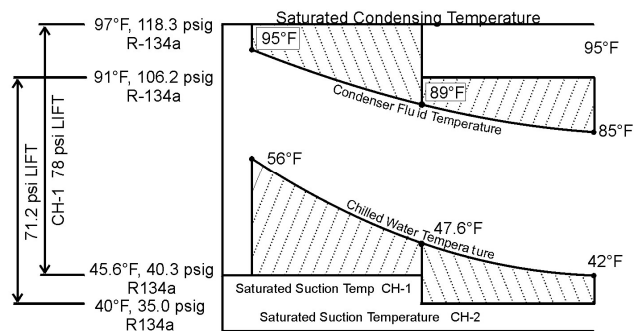
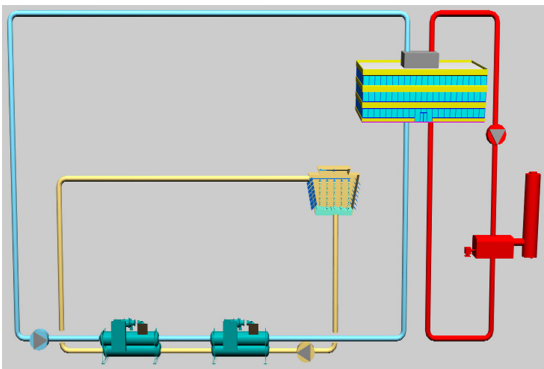

## Oil Coolers

McQuay centrifugal chillers, sizes 063 through 126, have a factory-mounted, water-cooled oil cooler with a temperature controlled water regulating valve and solenoid valve for each compressor. Cooling water connections are located at the rear of the unit, near the compressor and are shown on the specific unit certified drawings. Models WDC 063 through 087 and all WCC have the cooling water connections in the lower portion of one tube sheet.

WDC 063, 079, 087, 100 and 126 dual compressor chillers are equipped as above, but the water piping for the two oil coolers is factory piped to a common inlet and outlet connection.

Field water piping to the inlet and outlet connections must be installed according to good piping practices and must include stop valves to isolate the cooler for servicing. A 1" minimum cleanable filter (40 mesh maximum) and drain valve or plug must also be field installed. The water supply for the oil cooler must be from the chilled water circuit, or from an independent clean source such as city water. When using chilled water, it is important that the water pressure drop across the evaporator is greater than the pressure drop across the oil cooler or insufficient oil cooler flow will result. If the pressure drop across the evaporator is less than the oil cooler, the oil cooler must be piped across the chilled water pump, provided that its pressure drop is sufficient. The water flow through the oil cooler will be adjusted by the unit's regulating valve so that the temperature of oil supplied to the compressor bearings (leaving the oil cooler) is between 90°F and 110°F (32°C and 43°C).

Compressors using chilled water for oil cooling will often start with warm "chilled water" in the system until the chilled water loop temperature is pulled down. With cooling water in the 40°F to 55°F (4°C to 13°C) range, considerably less water will be used and the pressure drop will be greatly reduced. The following table contains oil cooler data at various inlet water temperatures.

**Table 7, Oil Cooler Performance**

	Hot Side POE Lube	Cold Side Water	Cold Side Water	Cold Side Water	Cold Side Water
<b>WSC 063 - 087</b>					
Flow, gpm	9.9	11.9	2.9	2.0	1.54
Inlet Temperature, °F	118.0	80.0	65.0	55.0	45.0
Outlet Temperature, °F	100.0	87.3	94.5	98.3	101.4
Pressure Drop, psi	-	4.3	0.3	0.14	0.09
<b>WSC 100 - 126</b>					
Flow, gpm	15.8	21.9	5.11	3.5	2.7
Inlet Temperature, °F	120.0	80.0	65.0	55.0	45.0
Outlet Temperature, °F	100.0	87.0	95.0	99.0	102.3
Pressure Drop, psi	-	3.78	0.23	0.11	0.07

**NOTES:**

1. Data is for a single compressor (oil cooler). Double the flow rates shown for WDC dual compressor chillers.
2. Pressure drop includes the oil cooler and control valve.

When supplied with city water, the oil piping must discharge through a trap into an open drain to prevent draining the cooler by siphoning. The city water can also be used for cooling tower makeup by discharging it into the tower sump from a point above the highest possible water level.

**NOTE:** Particular attention must be paid to chillers with variable chilled water flow through the evaporator. The pressure drop available at low flow rates can very well be insufficient to supply the oil cooler with enough water. In this case an auxiliary booster pump can be used or city water employed.

**Cooling Water Connection Sizes:** WDC/WCC 100/126 have 1 1/2 in. FPT connections, all other WDC and WSCs are 1 in. FPT.



**Figure 16, Oil Cooler Piping Across Chilled Water Pump**

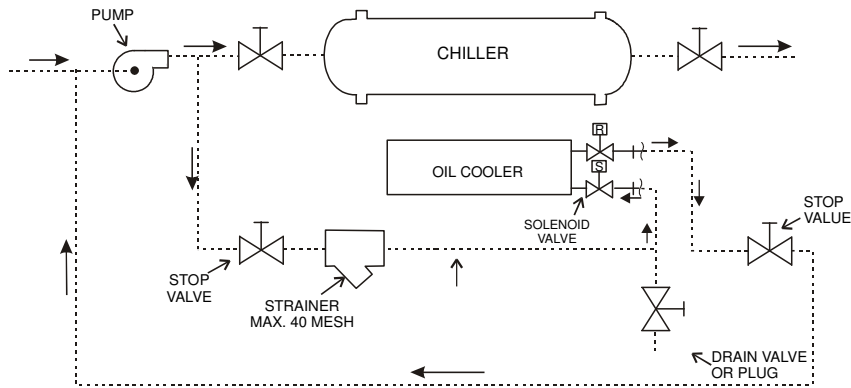

**Figure 17, Oil Cooler Piping With City Water**

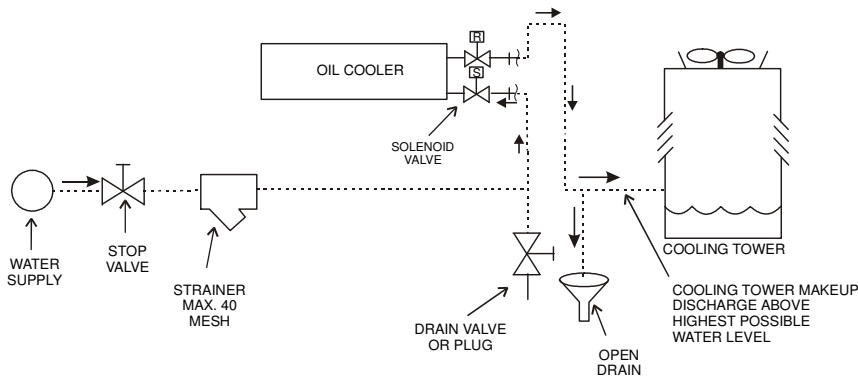

## Pumps

Model WSC, WDC and WCC chiller compressor motors operate at 3600 rpm on 60 Hz power (3000 rpm on 50 Hz). When VFDs are employed, the hertz/speed can be reduced by 70%. To avoid the possibility of objectionable harmonics in the system piping, 4-pole, 1800/1500 rpm system pumps should be used. The condenser water pump(s) must be cycled off when the last chiller of the system cycles off. This will keep cold condenser water from migrating refrigerant to the condenser. Cold liquid refrigerant in the condenser can make start-up difficult. In addition, turning off the condenser water pump(s) when the chillers are not operating will conserve energy.

## Piping

Piping must be adequately supported to remove weight and strain on the chiller's fittings and connections. Be sure piping is adequately insulated. Install a cleanable 20-mesh water strainer upstream of the evaporator and condenser. Install enough shutoff valves to permit draining water from the evaporator or condenser without draining the complete system.

### CAUTION

**Freeze Notice: The evaporator and condenser are not self-draining. Both must be blown out to completely remove water to help prevent freezeup.**

Include thermometers and pressure gauges at the chiller inlet and outlet connections and air vents at the high points of piping. The water heads can be interchanged (end for end), allowing water connections to be made at either end of the unit. Use new head gaskets when interchanging water heads. When water pump noise is objectionable, use rubber isolation sections at both the inlet and outlet of the pump. Vibration eliminator sections in the condenser inlet and outlet water lines are not normally required. Where noise and vibration are critical and the unit is mounted on spring isolators, flexible piping and conduit connections are necessary. If not factory installed, a flow switch or pressure differential switch must be installed in the leaving chilled water line in accordance with the flow switch manufacturer's instructions.

Victaulic connections are AWWA C-606 on 14-inch and larger sizes. Field supply transitions if AGS type grooves are used on the field piping.

## Filtering and Treatment

Owners and operators must be aware that if the unit is operating with a cooling tower, cleaning and flushing the cooling tower is required. Make sure tower blow-down or bleed-off is operating. Atmospheric air contains many contaminants, which increases the need for water treatment. The use of untreated water will result in corrosion, erosion, slime buildup, scaling, or algae formation. A water treatment service should be used. McQuay International is not responsible for damage or faulty operation from untreated or improperly treated water.

## Machine Room Ventilation

In the market today, centrifugal chillers are available with either hermetic or open type motors. Hermetic motors are cooled with refrigerant and dissipate their heat through the cooling tower. On the other hand, open motors circulate equipment room air across themselves for cooling and reject the heat to the equipment room. McQuay chillers have hermetic motors and DO NOT require additional ventilation.

For chillers with open-drive type, air-cooled motors, good engineering practice dictates that the motor heat be removed to prevent high equipment room temperatures. In many applications this requires a large volume of ventilation air, or mechanical cooling to properly remove this motor heat.

**EXAMPLE:** 1000 tons x 0.6 kW/Ton x 0.04 motor heat loss x 0.284 Tons/kW = 7 tons (24 kW) cooling

The energy and installation costs of ventilation or mechanical cooling equipment must be considered when evaluating various chillers. For a fair comparison, the kW used for the ventilation fans, or if mechanical cooling is required, the additional cooling and fan energy must be added to the open motor compressor energy when comparing hermetic drives. Additionally, significant costs occur for the purchase, installation, and maintenance of the ventilation or air handling units.

Equipment room ventilation and safety requirements for various refrigerants is a complex subject and is updated from time to time. The latest edition of ASHRAE 15 should be consulted.

## Thermal Storage

McQuay chillers are designed for use in thermal storage systems. The chillers have two operating conditions that must be considered. The first is normal air-conditioning duty where leaving evaporator fluid temperatures range from 40°F to 45°F (4.4°C to 7.2°C). The second condition occurs during the ice making process when leaving fluid temperatures are in the 22°F to 26°F (-5.6°C to -3.3°C) range.

The MicroTech II control system will accommodate both operating points. The ice mode can be started or stopped by an input signal to the microprocessor from a BAS or through a chilled water reset signal. When a signal is received to change from the ice mode to the normal operating mode, the chiller will shut down until the system fluid temperature rises to the higher setpoint. The chiller will then restart and continue operation at the higher leaving fluid temperature. When changing from normal cooling to the ice mode, the chiller will load to maximum capacity until the lower setpoint is reached.

Computer selections must be made to check that the chiller will operate at both conditions. If the “ice mode” is at night, the pressure differentials between the evaporator and condenser are usually similar to normal cooling applications. The leaving fluid temperature is lower, but the condensing temperature is also lower because the cooling tower water is colder. If the ice mode can also operate during the day, when cooling tower water temperatures are high, a proper selection becomes more difficult because the two refrigerant pressure differentials are significantly different.

A three-way condenser water control valve is always required.

## Variable Speed Pumping

Variable speed pumping involves changing system water flow relative to cooling load changes. McQuay centrifugal chillers are designed for this duty with two limitations.

First, the rate of change in the water flow needs to be slow, not greater than 10% of the change per minute. The chiller needs time to sense a load change and respond.

Second, the water velocity in the vessels must be 3 to 10 fps (0.91 and 3.0 m/sec). Below 3 fps (0.91 m/sec), laminar flow occurs which reduces heat transfer. Above 10 fps (3.0 m/sec), excessively high pressure drops and tube erosion occur. These flow limits can be determined from the McQuay selection program.

We recommend variable flow only in the evaporator because there is virtually no change in chiller efficiency compared to constant flow. In other words, there is no chiller energy penalty. Although variable speed pumping can be done in the condenser loop, it is usually unwise. The intent of variable flow is to reduce pump horsepower. However, reducing condenser water flow increases the chiller's condensing pressure, increasing the lift that the compressor must overcome which, in turn, increases the compressor's energy use. Consequently, pump energy savings can be lost because the chiller operating power is significantly increased.

Low condenser flow can cause premature tube fouling and subsequent increased compressor power consumption. Increased cleaning and/or chemical use can also result.

## Vibration Mounting

Every McQuay chiller is run tested and compressor vibration is measured and limited to a maximum rate of 0.14 inches per second, which is considerably more stringent than other available compressors. Consequently, floor-mounted spring isolators are not usually required. Rubber mounting pads are shipped with each unit. It is wise to continue to use piping flexible connectors to reduce sound transmitted into the pipe and to allow for expansion and contraction.

## Operating/Standby Limits

Equipment room temperature, standby

- Water in vessels and oil cooler: 32°F to 122°F (0°C to 50°C)
- Without water in vessels and oil cooler: 0°F to 140°F (-18°C to 60°C)
- WMC without water in vessels: 0°F to 130°F (-18°C to 54.4 °C)
- Equipment room temperature, operating: 32°F to 104°F (0°C to 40°C)
- Maximum entering condenser water temperature, startup: design plus 5 degrees F (2.7 degrees C)
- Maximum entering condenser water temperature, operating: job specific design temperature
- Minimum entering condenser water temperature, operating: see page 45.
- Minimum leaving chilled *water* temperature: 38°F (3.3°C)
- Minimum leaving chilled fluid temperature with correct anti-freeze fluid: 15°F (9.4°C)
- Maximum entering chilled water temperature, operating: 90°F (32.2°C)
- Maximum oil cooler/VFD entering temperature: 90°F (32.2°C)
- Minimum oil cooler/VFD entering temperature: 42°F (5.6°C)

## System Water Volume

All chilled water systems need adequate time to recognize a load change, respond to that load change and stabilize, without undesirable short cycling of the compressors or loss of control. In air conditioning systems, the potential for short cycling usually exists when the building load falls below the minimum chiller plant capacity or on close-coupled systems with very small water volumes.

Some of the things the designer should consider when looking at water volume are the minimum cooling load, the minimum chiller plant capacity during the low load period and the desired cycle time for the compressors.

Assuming that there are no sudden load changes and that the chiller plant has reasonable turndown, a rule of thumb of “gallons of water volume equal to two to three times the chilled water gpm flow rate” is often used.

A properly designed storage tank should be added if the system components do not provide sufficient water volume.

## Relief Valves

### Vessel Relief Valves

*Figure 18, Typical Vent Piping*

Relief valve connection sizes are 1-inch FPT and are in the quantity shown in Table 9 and Table 10 for the evaporator and condenser. In addition, there is a relief valve (3/8 inch flare) on the top of the oil sump of all units.

All relief valves (including the oil sump) must be piped to the outside of the building in accordance with ANSI/ASHRAE 15-2001. The new 2001 standard has revised the calculation method compared to previous issues.

Twin relief valves, mounted on a transfer valve, are used on the condenser so that one relief valve can be shut off and removed for testing or replacement, leaving the other in operation. Only one of the two valves is in operation at any time. Where 4 valves are shown, on some large vessels, they consist of two relief valves mounted on each of two transfer valves. Only two relief valves of the four are active at any time.

Vent piping is sized for only one valve of the set since only one can be in operation at a time.

### Relief Pipe Sizing (ASHRAE Method)

Relief valve pipe sizing is based on the discharge capacity for the given evaporator or condenser and the length of piping to be run.

McQuay centrifugal chillers have the following relief valve settings and discharge capacity:

WSC/WCC evaporator and condenser = 200 psi, 75.5 lb of air/min

WDC evaporator = 180 psi, 68.5 lb of air/min

WDC condenser = 225 psi, 84.4 lb of air/min

Since the pressures and valve size are fixed for McQuay chillers, the ASHRAE equation can be reduced to the simple table shown below.

**Table 8, Relief Valve Piping Sizes**

Pipe Size inch (NPT)	1 1/4	1 1/2	2	2 1/2	3	4
Moody Factor	0.0209	0.0202	0.0190	0.0182	0.0173	0.0163
Equivalent length (ft)	2.2	18.5	105.8	296.7	973.6	4117.4

NOTE: A 1-inch pipe is too small to handle these valves. A pipe increaser must be installed at the valve outlet.

Per ASHRAE Standard 15, the pipe size cannot be less than the relief device. The discharge from more than one relief valve can be run into a common header, the area of which shall not be less than the sum of the areas of the connected pipes. For further details, refer to ASHRAE Standard 15. The common header can be calculated by the formula:

$$D_{Common} = \left( D_1^2 + D_2^2 \dots D_n^2 \right)^{0.5}$$

The above information is a guide only. Consult local codes and/or latest version of ASHRAE Standard 15 for sizing data.

### Standby Power

The McQuay dual compressor chillers have a considerable advantage over the same capacity single compressor chillers when it comes to installations incorporating engine-driven standby generators for emergency power. Starting with only one compressor greatly reduces the load on the power plant and can reduce its size, saving considerable plant first cost.

It is essential that any centrifugal chiller connected to standby power come to a complete stop and then be restarted with the standby power. Attempting to switch from regular line power to auxiliary power while the compressor is running can result in extreme transient torque that will severely damage the compressor.

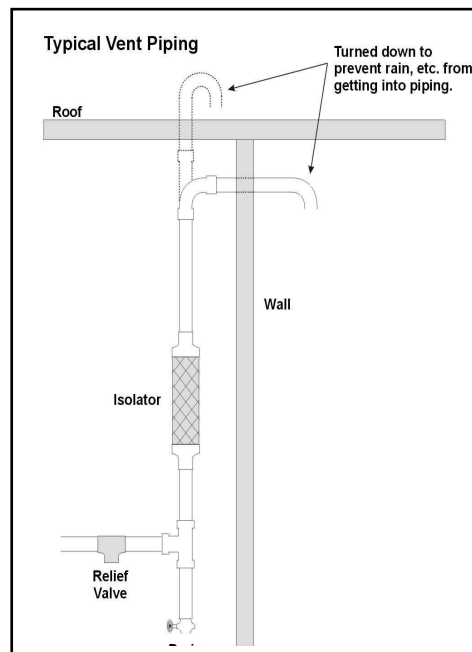

# Electrical Data

## Wiring and Conduit

Wire sizes must comply with local and state electrical codes. Where total amperes require larger conductors than a single conduit would permit, limited by dimensions of motor terminal box, two or more conduits can be used. Where multiple conduits are used, all three phases must be balanced in each conduit. Failure to balance each conduit will result in excessive heating of the conductors and unbalanced voltage.

An interposing relay can be required on remote mounted starter applications when the length of the conductors run between the chiller and starter is excessive.

**Note:** On WDC and WCC dual compressor units, dual power leads are standard, requiring separate power leads properly sized and protected to each compressor starter or VFD. Separate disconnects must be used.

Use only copper supply wires with ampacity based on 75°C conductor rating. (Exception: for equipment rated over 2000 volts, 90°C or 105°C rated conductors shall be used).

## NOTES for Following Wiring Diagram

1. Compressor motor starters are either factory mounted and wired, or shipped separate for field mounting and wiring. If provided by others, starters must comply with McQuay specification 359AB99. All line and load side power conductors must be copper.
2. If starters are freestanding, then field wiring between the starter and the control panel is required. Minimum wire size for 115 Vac is 12 GA for a maximum length of 50 feet. If greater than 50 feet, refer to McQuay for recommended wire size minimum. Wire size for 24 Vac is 18 GA. All wiring to be installed as NEC Class 1 wiring system. All 24 Vac wiring must be run in separate conduit from 115 Vac wiring. Main power wiring between starter and motor terminal is factory-installed when units are supplied with unit-mounted starters. Wiring of free-standing starter must be wired in accordance with NEC and connection to compressor motor terminals must be made with copper wire and copper lugs only. Control wiring on free-standing starters is terminated on a terminal strip in the motor terminal box (not the unit control panel). Wiring from the unit control panel to the motor terminal is done in the factory.
3. For optional sensor wiring, see unit control diagram. It is recommended that dc wires be run separately from 115 Vac wiring.
4. Customer furnished 24 or 120 Vac power for alarm relay coil can be connected between UTB1 terminals 84 power and 51 neutral of the control panel. For normally open contacts, wire between 82 & 81. For normally closed contacts, wire between 83 & 81. The alarm is operator programmable. The maximum rating of the alarm relay coil is 25 VA.
5. Remote on/off control of unit can be accomplished by installing a set of dry contacts between terminals 70 and 54.
6. Evaporator and condenser flow switches are required and must be wired as shown. If field supplied pressure differential switches are used then these must be installed across the vessel and not the pump.
7. Customer supplied 115 Vac, 20 amp power for optional evaporator and condenser water pump control power and tower fans is supplied to unit control terminals (UTB1) 85 power / 86 neutral, PE equipment ground.
8. Optional customer supplied 115 Vac, 25 VA maximum coil rated chilled water pump relay (EP 1 & 2) can be wired as shown. This option will cycle the chilled water pump in response to building load.
9. The condenser water pump must cycle with the unit. A customer supplied 115 Vac 25 VA maximum coil rated condenser water pump relay (CP1 & 2) is to be wired as shown.
10. Optional customer supplied 115 Vac, 25 VA maximum coil rated cooling tower fan relays (CL - C4) can be wired as shown. This option will cycle the cooling tower fans in order to maintain unit head pressure.
11. Auxiliary 24 Vac rated contacts in both the chilled water and condenser water pump starters can be wired as shown for additional protection.
12. For VFD, Wye-Delta, and solid state starters connected to six (6) terminal motors, the conductors between the starter and motor carry phase current and their ampacity must be based on 58 percent of the motor rated load amperes (RLA) times 1.25. Wiring of free-standing starter must be in accordance with the NEC and connection to the compressor motor terminals shall be made with copper wire and copper lugs only. Main power wiring between the starter and motor terminals is factory-installed when chillers are supplied with unit-mounted starters.
13. Optional Open Choices BAS interfaces. The locations and interconnection requirements for the various standard protocols are found in their respective installation manuals, obtainable from the local McQuay sales office and also shipped with each unit:  
Modbus IM 743-0                      LonWorks IM 735-0                      BACnet IM 736-0
14. The "Full Metering" or "Amps Only Metering" option will require some field wiring when free-standing starters are used. Wiring will depend on chiller and starter type. Consult the local McQuay sales office for information on specific selections.

**Figure 19, Typical Field Connection Diagram**

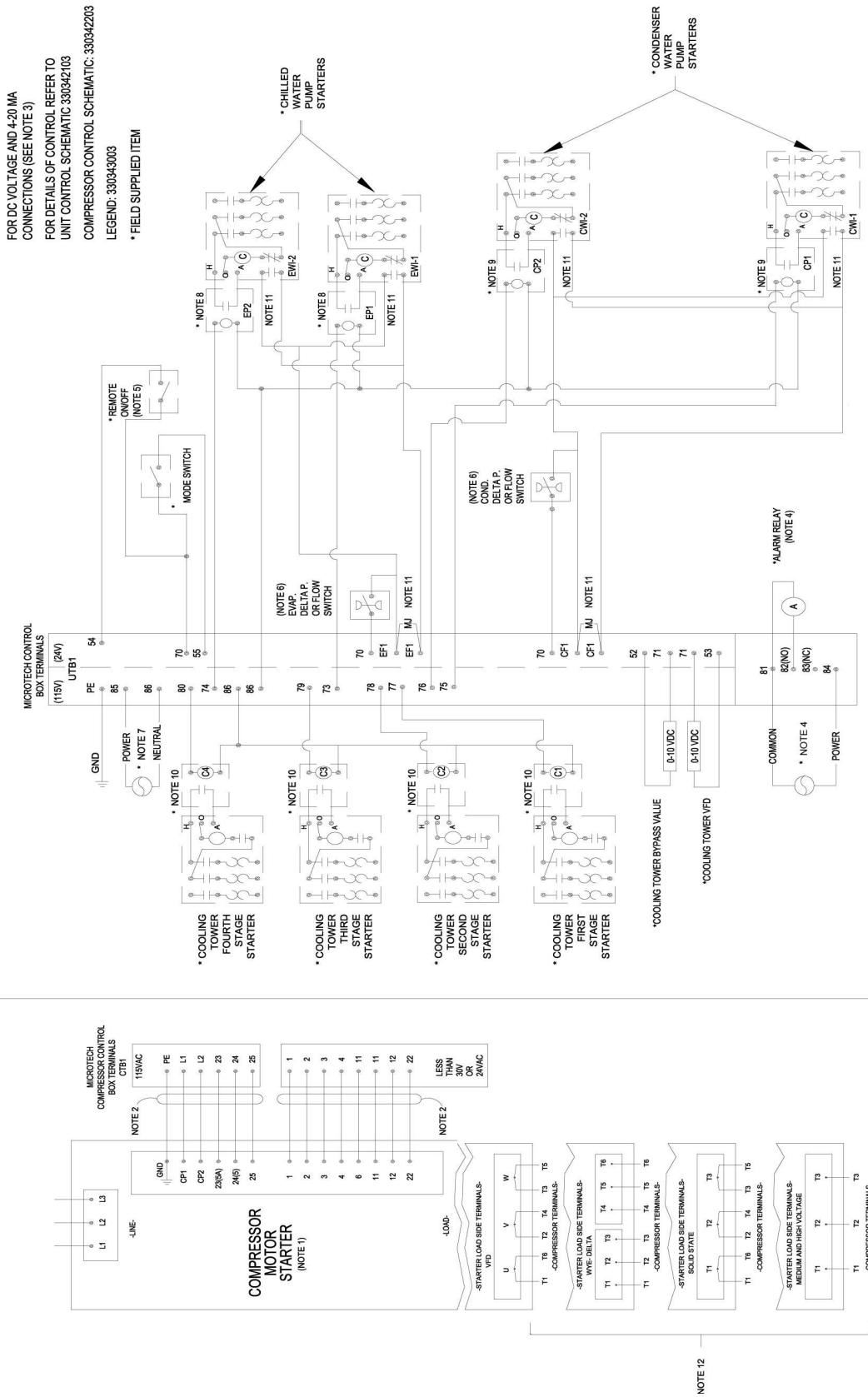

See notes on preceding page.

## Control Power

The 115-volt control power can be supplied from the starter or a transformer (meeting the requirements of McQuay Specification 359A999) separate from the starter. Either source must be properly fused with 20-amp dual element fuses or with a circuit breaker selected for motor duty. If the control transformer or other power source for the control panel is remote from the unit, conductors must be sized for a maximum voltage drop of 3%. Required circuit ampacity is 20 amps at 115 volts. Conductor size for long runs between the control panel and power source, based upon National Electrical Code limitations for 3% voltage drop, can be determined from the table below.

### Control Power Line Sizing

Maximum Length, ft (m)	Wire Size (AWG)	Maximum Length, ft (m)	Wire Size (AWG)
0 (0) to 50 (15.2)	12	120 (36.6) to 200 (61.0)	6
50 (15.2) to 75 (22.9)	10	200 (61.0) to 275 (83.8)	4
75 (22.9) to 120 (36.6)	8	275 (83.8) to 350 (106.7)	3

**Notes:**

1. Maximum length is the distance a conductor will traverse between the control power source and the unit control panel.
2. Panel terminal connectors will accommodate up to number 10 AWG wire. Larger conductors will require an intermediate junction box.

# Chiller Identification

To provide a wide range of components to match job requirements of capacity, efficiency and competitive initial cost, McQuay WSC, WDC and WCC centrifugal chillers are selected by computer and identified by their components.

The variations of compressor, impeller, gear ratio, evaporator and condenser tube surface and configuration provide over 1,000,000 combinations of standard components within the range of 200 to 2,700 tons. It is impractical to catalog all of these combinations. Therefore, computer selection for specific application conditions is required. The complete unit model code is then established as follows:

**Figure 20, Chiller Identification**

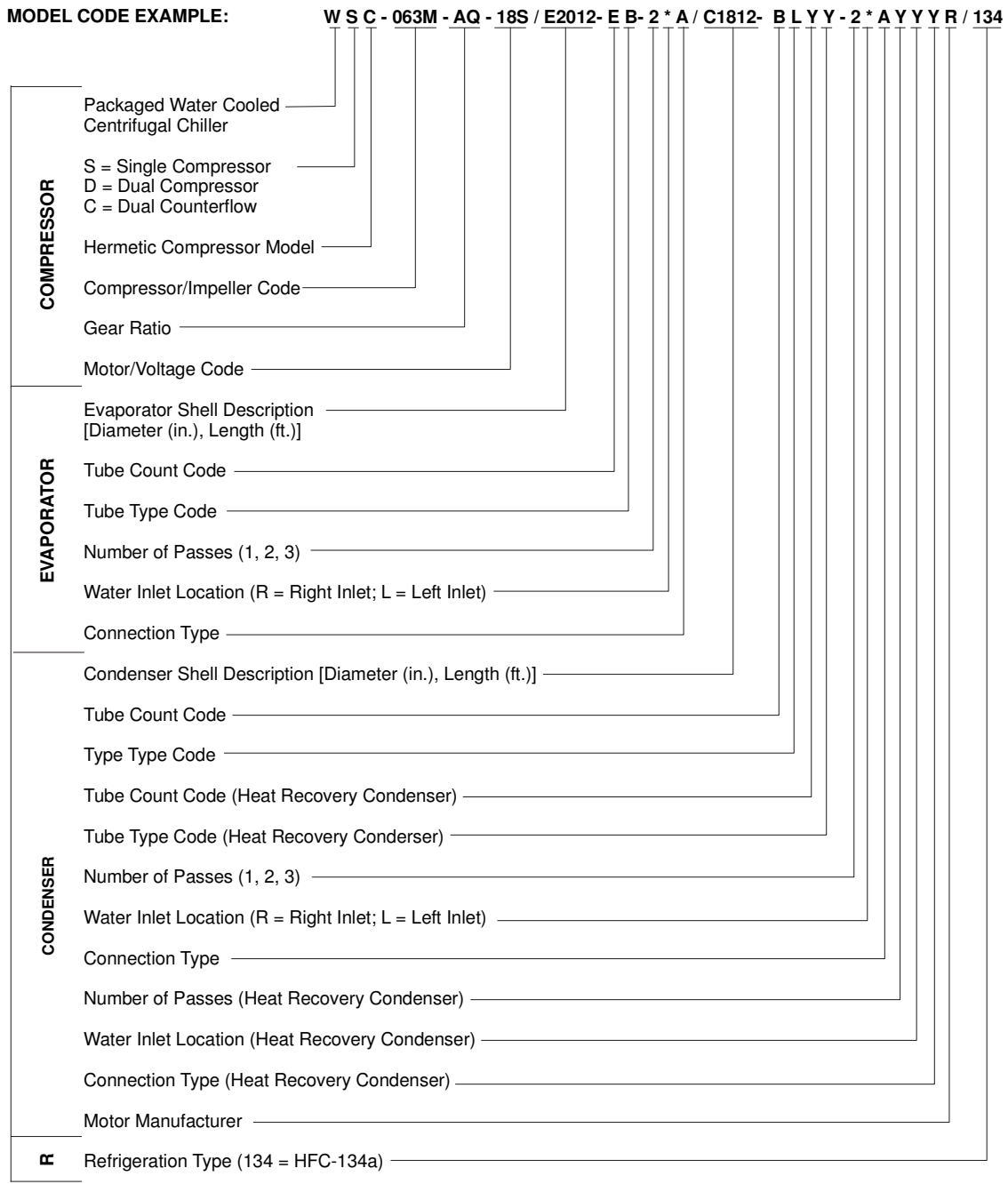



# Physical Data and Weights

## Evaporator

The optional insulation of cold surfaces includes the evaporator and *non-connection* water head, suction piping, compressor inlet, motor housing, and motor coolant suction line.

The standard insulation used is UL recognized (File # E55475). It is 3/4" thick ABS/PVC flexible foam with skin having a K factor of 0.28 at 75°F. The sheet insulation is fitted and cemented in place forming a vapor barrier, then painted with a resilient epoxy finish that resists cracking.

The insulation complies to appropriate requirements or has been tested in accordance with the following:

ASTM-C-177                      ASTM-C-534 Type 2                      UL 94-5V                      CAN/ULC S102-M88  
 ASTM-D-1056-91-2C1                      ASTM E 84                      MEA 186-86-M Vol. N

Refrigerant side design pressure is 200 psi (1380 kPa) on WSC and WCC units. WDC evaporators are 180 psi (1242 kPa) and condensers are 225 psi (1552 kPa). Standard water-side design pressure is 150 psi (1034 kPa) on all vessels. 300 psi (2068 kPa) is available as an option.

**Table 9, Evaporator Physical Data**

Evaporator Code	WSC	WDC	WCC	Water Volume gal (L)	Insulation Area sq ft (m <sup>2</sup> )	Vessel Dry Weight lb (kg)	Add for MWB lb (kg)	MWB Cover Only, Weight lb (kg)
E2009	X			31 (117)	82 (7.6)	2543 (1152)	478 (217)	148 (67)
E2012	X			37 (139)	84 (7.8)	2862 (1296)	478 (217)	148 (67)
E2209	X			38 (145)	66 (6.1)	2708 (1227)	600 (272)	175 (79)
E2212	X			45 (170)	90 (8.3)	3071 (1391)	600 (272)	175 (79)
E2212		X		63 (240)	90 (8.3)	3550 (1609)	600 (272)	175 (79)
E2216		X		79 (301)	144 (13.4)	4200 (1903)	600 (272)	175 (79)
E2412		X		88 (335)	131 (12.1)	4410 (1999)	700 (317)	240 (109)
E2416		X		110 (415)	157 (14.6)	5170 (2343)	700 (317)	240 (109)
E2609	X			61 (231)	76 (7.1)	3381 (1532)	899 (407)	302 (137)
E2612	X			72 (273)	102 (9.4)	3880 (1758)	899 (407)	302 (137)
E2612		X		101 (381)	102 (9.4)	4745 (2150)	899 (407)	302 (137)
E2616		X		126 (478)	162 (15.0)	5645 (2558)	899 (407)	302 (137)
E3009	X			74 (281)	86 (8.0)	4397 (1992)	1386 (628)	517 (234)
E3012	X			89 (336)	115 (10.6)	5075 (2299)	1386 (628)	517 (234)
E3016		X		157 (594)	207 (19.2)	7085 (3211)	1386 (628)	517 (234)
E3609	X			128 (484)	155 (14.4)	5882 (2665)	2115 (958)	805 (365)
E3612	X			152 (574)	129 (11.9)	6840 (3099)	2115 (958)	805 (365)
E3612*	X			156 (575)	129 (11.9)	6630 (3007)	2151 (976)	805 (365)
E3616		X		243 (918)	239 (22.2)	9600 (4351)	2115 (958)	805 (365)
E3620			X	219 (827)	207 (19.2)	8298 (3764)	2115 (958)	805 (365)
E4212	X			222 (841)	148 (13.7)	8922 (4042)	2836 (1285)	1181 (535)
E4216		X		347 (1313)	264 (24.5)	12215 (5536)	2836 (1285)	1181 (535)
E4220		X		481 (1819)	330 (30.6)	15045 (6819)	2836 (1285)	1181 (535)
E4220			X	319 (1208)	242 (22.5)	10853 (4923)	2836 (1285)	1181 (535)
E4812	X			327 (1237)	169 (15.6)	11125 (5040)	4578 (2074)	1837 (832)
E4816		X		556 (2106)	302 (281)	16377 (7429)	4578 (2074)	1837 (832)
E4820		X		661 (2503)	377 (35.0)	17190 (7791)	4578 (2074)	1837 (832)
E4820			X	456 (1728)	276 (25.6)	14618 (6630)	4578 (2074)	1837 (832)

**Notes:**

1. Water capacity is based on standard tube configuration and standard heads.
2. Vessel weight includes the shell, maximum tubes, and standard heads, no refrigerant.
3. MWB, marine water box, weight add is the water box weight minus a standard dished head weight.
4. \*Applies specifically to models under 800 tons with a 2-pass configuration, copper tubing and utilizing E3612 evaporator.

## Condenser

With positive pressure systems, the pressure variance with temperature is always predictable, and the vessel design and relief protection are based upon pure refrigerant characteristics. Negative pressure systems are not ASME designed, inspected and stamped. R-134a requires ASME vessel design, inspection and testing and uses spring-loaded pressure relief valves. Negative pressure units use rupture disks. When an over pressure condition occurs, the rupture disk is permanently destroyed. Spring-loaded relief valves purge only the amount of refrigerant required to reduce the system pressure to the valve setting level and then close.

Refrigerant side design pressure is 200 psi (1380 kPa) on WSC and WCC units and 225 psi (1552 kPa) on WDC units. Standard water side design pressure is 150 psi (1034 kPa) on all vessels. 300 psi (2068 kPa) is available as an option.

## Pumpdown

To facilitate compressor service, all McQuay centrifugal chillers are designed to permit pumpdown and isolation of the entire refrigerant charge in the unit's condenser. WDC dual compressor units, and single compressor units equipped with the optional suction shutoff valve, can also be pumped down into the evaporator.

**Table 10, Condenser Physical Data**

Condenser Code	WSC	WDC	WCC	Pumpdown Capacity lb (kg)	Water Volume gal (L)	Vessel Dry Weight lb (kg)	Add for MWB lb (kg)	MWB Cover Only, Weight lb (kg)
C1809	X			597 (271)	34 (128)	1835 (831)	402 (182)	124 (56)
C1812	X			845 (384)	44 (166)	2183 (989)	402 (182)	124 (56)
C2009	X			728 (330)	47 (147)	2230 (1010)	478 (216)	148 (67)
C2012	X			971 (440)	62 (236)	2677 (1213)	478 (216)	148 (67)
C2209	X			822 (372)	60 (228)	2511 (1137)	478 (216)	148 (67)
C2212	X			1183 (537)	76 (290)	3031 (1373)	478 (216)	148 (67)
C2212		X		1110 (504)	89 (337)	3075 (1395)	478 (216)	148 (67)
C2216		X		1489 (676)	114 (430)	3861 (1751)	478 (216)	148 (67)
C2416		X		1760 (799)	143 (540)	4647 (2188)	685 (310)	230 (104)
C2609	X			1242 (563)	89 (335)	3210 (1454)	902 (408)	302 (137)
C2612	X			1656 (751)	111 (419)	3900 (1767)	902 (408)	302 (137)
C2616		X		2083 (945)	159 (603)	5346 (2425)	902 (408)	302 (137)
C3009	X			1611 (731)	114 (433)	4356 (1973)	1420 (643)	517 (234)
C3012	X			2148 (975)	144 (545)	5333 (2416)	1420 (643)	517 (234)
C3016		X		2789 (1265)	207 (782)	6752 (3063)	1420 (643)	517 (234)
C3612	X			2963 (1344)	234 (884)	7508 (3401)	2115 (958)	805 (364)
C3616		X		3703 (1725)	331 (1251)	9575 (4343)	2115 (958)	805 (364)
C3620			X	4991 (2264)	356 (1347)	10540 (4781)	2115 (958)	805 (364)
C4212	X			3796 (1722)	344 (1302)	10267 (4651)	2836 (1285)	1181 (535)
C4216		X		5010 (2273)	475 (1797)	12662 (5743)	2836 (1285)	1181 (535)
C4220		X		5499 (2494)	634 (2401)	17164 (7785)	2836 (1285)	1181 (535)
C4220			X	6487 (2942)	524 (1983)	14160 (6423)	2836 (1285)	1181 (535)
C4812	X			4912 (2228)	491 (1855)	13077 (5924)	4578 (2074)	1837 (8320)
C4816		X		5581 (2532)	717 (2715)	18807 (8530)	4578 (2074)	1837 (8320)
C4820		X		7034 (3191)	862 (3265)	23106 (10481)	4578 (2074)	1837 (8320)
C4820			X	8307 (3768)	727 (2753)	18907 (8576)	4578 (2074)	1837 (8320)

Notes:

1. Condenser pumpdown capacity based on 90% full at 90°F.
2. Vessel weight includes the shell, maximum tubes, and standard heads, no refrigerant.
3. MWB, marine water box, weight add is the water box weight minus a standard dished head weight.

## Compressor

**Table 11, Compressor Weights**

Compressor	063	079	087	100	113	126
Weight lb (kg)	3200 (1440)	3200 (1440)	3200 (1440)	6000 (2700)	6000 (2700)	6000 (2700)

# Complete Unit

**Table 12, Unit Weights, Single Compressor, WSC**

Unit	Evaporator / Condenser	Unit Refrig. Charge (1)	Max. Unit Weight Without Starter		Max. Unit Weight With Starter	
			Shipping	Operating	Shipping	Operating
WSC063	2009 / 1809	410 (186)	8412 (3816)	8949 (4059)	9612 (4360)	10149 (4604)
WSC063	2012 / 1812	539 (244)	9284 (4211)	9955 (4516)	10484 (4756)	11155 (5060)
WSC063	2209 / 2009	479 (217)	9119 (4136)	9841 (4464)	10319 (4681)	11040 (5008)
WSC063	2212 / 2012	631 (286)	10182 (4619)	11077 (5025)	11382 (5163)	12277 (5569)
WSC063	2209 / 2209	495 (224)	9416 (4271)	10235 (4643)	10616 (4815)	11435 (5187)
WSC063	2212 / 2212	651 (295)	10557 (4789)	11570 (5248)	11757 (5333)	12770 (5792)
WSC063	2609 / 2209	651 (295)	10248 (4648)	11258 (5107)	11448 (5193)	12458 (5651)
WSC063	2612 / 2212	859 (389)	11577 (5251)	12817 (5806)	12777 (5796)	14017 (6358)
WSC063	2609 / 2609	686 (311)	10984 (4982)	12228 (5547)	12184 (5527)	13428 (6091)
WSC063	2612 / 2612	905 (410)	12494 (5667)	14020 (6359)	13694 (6203)	15220 (6904)
WSC063	3009 / 2609	825 (374)	12892 (5848)	14246 (6462)	14092 (6392)	15446 (7006)
WSC063	3012 / 2612	1098 (497)	13903 (6306)	15569 (7062)	15103 (6851)	16769 (7606)
WSC079	2209 / 2209	495 (224)	10140 (4600)	10959 (4971)	11340 (5144)	12159 (5515)
WSC079	2212 / 2212	651 (295)	11281 (5117)	12294 (5577)	12481 (5661)	13494 (6121)
WSC079	2609 / 2209	651 (295)	10980 (4981)	11990 (5439)	12180 (5525)	13190 (5983)
WSC079	2612 / 2212	859 (389)	12309 (5592)	13548 (6145)	13509 (6128)	14749 (6690)
WSC079	2609 / 2609	686 (311)	11716 (5314)	12960 (5879)	12916 (5859)	14160 (6423)
WSC079	2612 / 2612	905 (410)	13226 (5999)	14752 (6692)	14426 (6544)	15952 (7236)
WSC079	3009 / 2609	825 (374)	12892 (5848)	14246 (6462)	14092 (6392)	15446 (7006)
WSC079	3012 / 2612	1098 (497)	14635 (6638)	16301 (7394)	15835 (7183)	17501 (7938)
WSC079	3009 / 3009	855 (387)	14076 (6385)	15644 (7096)	15276 (6929)	16844 (7640)
WSC079	3012 / 3012	1147 (520)	16119 (7312)	18061 (8192)	17319 (7856)	19261 (8737)
WSC079	3609 / 3009	1173 (531)	15913 (7218)	17929 (8133)	17113 (7762)	19129 (8677)
WSC079	3612 / 3012	1563 (708)	18340 (8319)	20807 (9438)	19540 (8863)	22007 (9982)
WSC087	2609 / 2209	651 (295)	10980 (4981)	11990 (5439)	12180 (5525)	13190 (5983)
WSC087	2612 / 2212	859 (389)	12309 (5592)	13549 (6146)	13509 (6128)	14749 (6690)
WSC087	2609 / 2609	686 (311)	11716 (5314)	12960 (5879)	12916 (5859)	14160 (6423)
WSC087	2612 / 2612	905 (410)	13226 (5999)	14752 (6692)	14426 (6544)	15952 (7236)
WSC087	3009 / 2609	825 (374)	12892 (5848)	14246 (6462)	14092 (6392)	15446 (7006)
WSC087	3012 / 2612	1098 (497)	14635 (6638)	16301 (7394)	15835 (7183)	17501 (7938)
WSC087	3009 / 3009	862 (390)	14076 (6385)	15644 (7096)	15276 (6929)	16844 (7640)
WSC087	3012 / 3012	1147 (520)	16119 (7312)	18060 (8192)	17318 (7855)	19260 (8736)
WSC087	3609 / 3009	1173 (531)	15913 (7218)	17929 (8133)	17113 (7762)	19129 (8677)
WSC087	3612 / 3012	1563 (708)	18339 (8319)	20806 (9438)	19539 (8863)	22006 (9982)
WSC087	3612 / 3612	1635 (740)	20584 (9337)	23799 (10795)	21784 (9881)	24999 (11340)
WSC087*	3612 / 3012	1563 (708)	18129 (8223)	20633 (9359)	19329 (8767)	21833 (9903)
WSC087*	3612 / 3612	1635 (740)	20374 (9241)	23626 (10717)	21574 (9786)	24826 (11261)
WSC100	3012 / 3012	1147 (520)	19397 (8798)	21339 (9679)	20597 (9343)	22539 (10224)
WSC100	3612 / 3012	1563 (708)	21578 (9788)	24045 (10907)	22778 (10332)	25245 (11451)
WSC100	3612 / 3612	1635 (740)	23826 (10807)	27041 (12266)	25026 (11352)	28241 (12810)
WSC100*	3612 / 3012	1563 (708)	21368 (9692)	23872 (10828)	22568 (10237)	25072 (11372)
WSC100*	3612 / 3612	1635 (740)	23616 (10712)	26868 (12187)	24816 (11256)	28068 (12731)
WSC100	4212 / 3612	2081 (943)	26457 (12001)	30260 (13726)	27657 (13545)	31460 (14270)
WSC100	4212 / 4212	2164 (980)	29298 (13290)	34024 (15433)	30498 (13834)	35224 (15978)
WSC100	4812 / 4212	2688 (1217)	32024 (14526)	37623 (17066)	33224 (15070)	38823 (17610)
WSC113	3012 / 3012	1147 (520)	19397 (8798)	21339 (9679)	20597 (9343)	22539 (10224)
WSC113	3612 / 3012	1563 (708)	21578 (9788)	24045 (10907)	22778 (10332)	25245 (11451)
WSC113	3612 / 3612	1635 (740)	23826 (10807)	27041 (12266)	25026 (11352)	28241 (12810)
WSC113*	3612 / 3012	1563 (708)	21368 (9692)	23872 (10828)	22568 (10237)	25072 (11372)
WSC113*	3612 / 3612	1635 (740)	23616 (10712)	26868 (12187)	24816 (11256)	28068 (12731)
WSC113	4212 / 3612	2081 (943)	26457 (12001)	30260 (13726)	27657 (13545)	31460 (14270)
WSC113	4212 / 4212	2164 (980)	29298 (13290)	34024 (15433)	30498 (13834)	35224 (15978)
WSC113	4812 / 4212	2688 (1217)	32024 (14526)	37623 (17066)	33224 (15070)	38823 (17610)
WSC113	4812 / 4812	2867 (1299)	35016 (15883)	41817 (18968)	36216 (16427)	43017 (19513)
WSC126	3612 / 3012	1563 (708)	21680 (9834)	24147 (10953)	22880 (10378)	25347 (11497)
WSC126	3612 / 3612	1635 (740)	23928 (10854)	27143 (12312)	25128 (11398)	28343 (12856)
WSC126*	3612 / 3012	1563 (708)	21470 (9739)	23974 (10874)	22670 (10283)	25174 (11419)
WSC126*	3612 / 3612	1635 (740)	23718 (10758)	26970 (12233)	24918 (11303)	28170 (12778)
WSC126	4212 / 3612	2081 (943)	26457 (12001)	30260 (13726)	27657 (12545)	31460 (14270)
WSC126	4212 / 4212	2164 (980)	29298 (13290)	34024 (15433)	30498 (13834)	35224 (15978)
WSC126	4812 / 4212	2164 (980)	32024 (14526)	37623 (17066)	33224 (15070)	38823 (17610)
WSC126	4812 / 4812	2867 (1299)	35016 (15883)	41817 (18968)	36216 (16427)	43017 (19513)

**Notes**

1. With starters (factory mounted) applies only to low voltage (200 to 600 volts) equipment.
2. \*Applies specifically to models under 800 tons with a 2-pass configuration, copper tubing and utilizing E3612 evaporator.

**Table 13, Dual Compressor, WDC/WCC**

Unit	Evaporator / Condenser Size	Max. Unit Weight Without Starter		Max. Unit Weight With Starter (1)	
		Shipping lbs. (kg)	Operating lbs. (kg)	Shipping lbs. (kg)	Operating lbs. (kg)
WDC063	2416 / 2416	18673 (8470)	20422 (9263)	21407 (9710)	23156 (10503)
WDC063	2416 / 2616	19365 (8784)	21294 (9577)	22099 (10024)	23848 (10817)
WDC063	2616 / 2416	19282 (8746)	21207 (9639)	22016 (9986)	23763 (10779)
WDC063	2616 / 2616	20025 (9083)	22091 (9939)	22759 (10323)	24646 (11179)
WDC063	3016 / 3016	23545 (10680)	26405 (11830)	26279 (11920)	28815 (13070)
WDC063	3616 / 3016	27763 (12604)	31018 (14082)	30163 (13694)	33418 (15172)
WDC063	3616 / 3616	32027 (14540)	35115 (15942)	33427 (15176)	37515 (17032)
WDC079	3016 / 3016	25131 (11399)	27671 (12551)	27531 (12488)	30071 (13640)
WDC079	3616 / 3016	28763 (13047)	32018 (14523)	31163 (14135)	34418 (15612)
WDC079	3616 / 3616	32027 (14527)	36115 (16382)	34427 (15616)	38515 (17470)
WDC079	4216 / 4216	44470 (20189)	51463 (23364)	47204 (21431)	54197 (24605)
WDC087	3016 / 3016	26157 (11865)	28697 (13017)	28891 (13105)	31431 (14257)
WDC087	3616 / 3016	29789 (13512)	33044 (14989)	32523 (14752)	35778 (15322)
WDC087	3616 / 3616	33053 (14993)	37141 (16847)	35787 (16233)	39875 (18087)
WDC087	4216 / 4216	44470 (20189)	51463 (23364)	47204 (21431)	54197 (24605)
WDC100, 113	3616 / 3616	41816 (18967)	46513 (21098)	See Note 2	See Note 2
WDC100, 113, 126	4216 / 4216	50470 (22893)	57463 (26065)	See Note 2	See Note 2
WDC100, 113, 126	4816 / 4816	59185 (26846)	68996 (31296)	See Note 2	See Note 2
WDC100, 113, 126	4220 / 4220	54802 (24858)	63248 (28689)	See Note 2	See Note 2
WDC100, 113, 126	4820 / 4820	65964 (29921)	77698 (35243)	See Note 2	See Note 2
WCC100, 113, 126	3620 / 3620	37645 (17091)	41334 (19268)	See Note 2	See Note 2
WCC100, 113, 126	4220 / 3620	41320 (18759)	45609 (21317)	See Note 2	See Note 2
WCC100, 113, 126	4220 / 4220	45314 (20573)	50281 (23767)	See Note 2	See Note 2
WCC100, 113, 126	4820 / 4220	49759 (22590)	56173 (26305)	See Note 2	See Note 2
WCC100, 113, 126	4820 / 4820	55927 (25391)	62528 (29876)	See Note 2	See Note 2

**Notes**

1. With starters (factory mounted) applies only to low voltage (200 to 600 volts) equipment.
2. Unit not available with factory mounted starters.

## Dimensions

**Notes:**

1. Drawings included in this section are for rough layout purposes only. Detailed certified drawings, as pdf files or paper copies, are available from the local McQuay sales office. Do not use catalog drawings for final construction.
2. Obtain specific unit certified drawings for detailed dimensions of water, oil cooler, and relief valve connections.
3. Dimensions in inches (mm).
4. See Physical Data and Weights section for component and unit weights.
5. Allow three feet of service access on all four sides, plus allow the length of the tubes, plus two feet on one end, for tube removal. The last two numbers in the vessel code are the tube length in feet. The NEC may require more than 3 feet clearance in front of control panels or starting equipment depending voltage and layout.
6. The adjustable control interface panel is shipped un-mounted from the unit. When mounted, it can be folded back within the confines of the unit width and height and still be viewable.
7. A 1-inch manufacturing tolerance must be accounted for in the design and installation process.

**Figure 21, WSC 063, 160 to 300 Tons (560 to 1050 kW)**

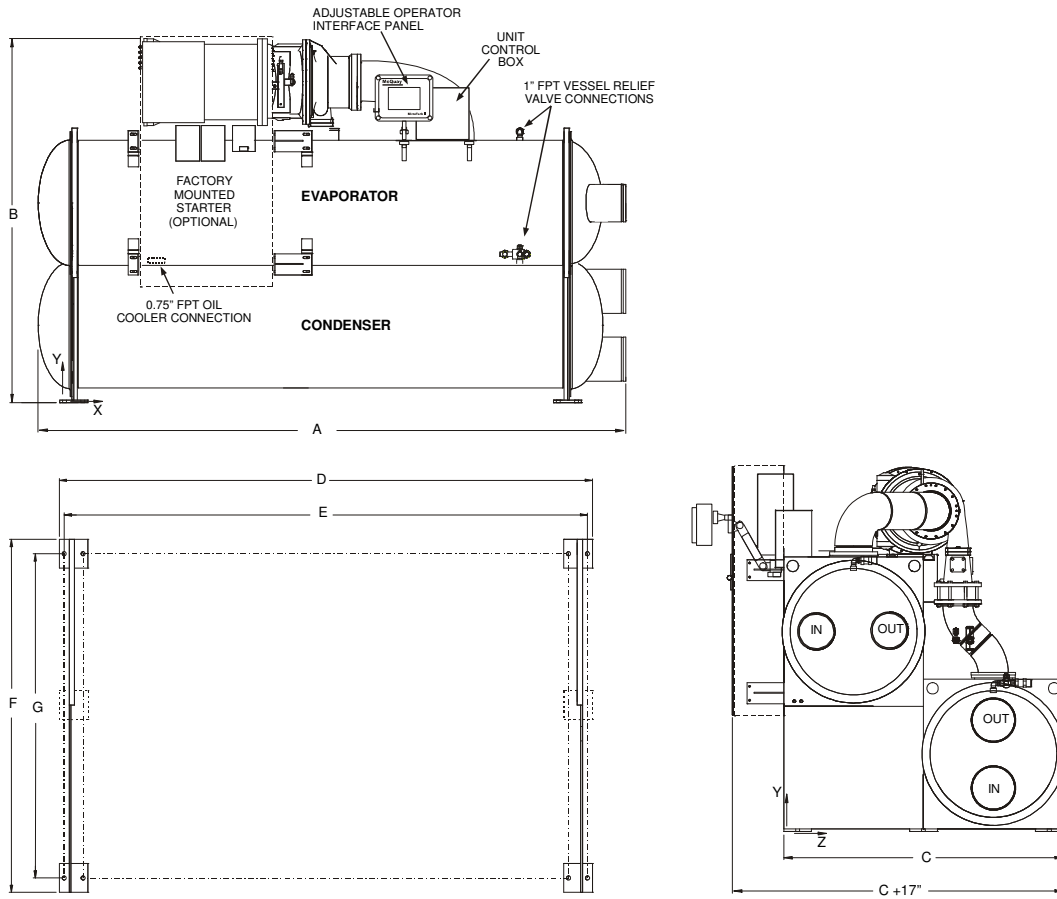

VESSEL CODE		OVERALL LENGTH			OVERALL HEIGHT	OVERALL WIDTH W/O STARTER	CENTER OF GRAVITY			FOOTPRINT				CONNECTIONS	
EVAP	COND	1&3 PASS	2 PASS	HEAD CONN. BOTH ENDS			X	Y	Z	D	E	F	G	EVAP 2 PASS	COND 2 PASS
		A	A	A											
E2009	C1809	134 (3404)	128 (3251)	134 (3404)	76 (1930)	42 (1067)	50 (1270)	37 (940)	16 (406)	113 (2870)	111 (2819)	42 (1067)	34 (864)	6	6
E2012	C1812	169 (4293)	163 (4140)	169 (4293)	76 (1930)	42 (1067)	68 (1727)	36 (914)	17 (432)	148 (3759)	145 (3683)	42 (1067)	34 (864)	6	6
E2209	C2009	134 (3404)	129 (3277)	134 (3404)	76 (1930)	42 (1067)	50 (1270)	36 (914)	17 (432)	113 (2870)	111 (2819)	42 (1067)	34 (864)	8	6
E2212	C2012	169 (4293)	164 (4166)	169 (4293)	76 (1930)	42 (1067)	68 (1727)	34 (864)	17 (432)	148 (3759)	145 (3683)	42 (1067)	34 (864)	8	6
E2209	C2209	134 (3404)	129 (3277)	134 (3404)	76 (1930)	42 (1067)	51 (1295)	35 (889)	17 (432)	113 (2870)	111 (2819)	42 (1067)	34 (864)	8	8
E2212	C2212	169 (4293)	164 (4166)	169 (4293)	76 (1930)	42 (1067)	68 (1727)	34 (864)	17 (432)	148 (3759)	145 (3683)	42 (1067)	34 (864)	8	8
E2609	C2209	134 (3404)	129 (3277)	134 (3404)	80 (2032)	46 (1168)	51 (1295)	37 (940)	20 (508)	113 (2870)	111 (2819)	46 (1168)	38 (965)	8	8
E2612	C2212	169 (4293)	164 (4166)	169 (4293)	80 (2032)	46 (1168)	69 (1753)	35 (889)	20 (508)	148 (3759)	145 (3683)	46 (1168)	38 (965)	8	8
E2609	C2609	134 (3404)	129 (3277)	134 (3404)	86 (2184)	48 (1219)	51 (1295)	40 (1016)	20 (508)	113 (2870)	111 (2819)	48 (1219)	40 (1016)	8	8
E2612	C2612	169 (4293)	164 (4166)	169 (4293)	86 (2184)	48 (1219)	69 (1753)	38 (965)	21 (533)	148 (3759)	145 (3683)	48 (1219)	40 (1016)	8	8
E3012	C2612	175 (4445)	167 (4242)	175 (4445)	90 (2286)	53 (1346)	67 (1702)	41 (1041)	21 (533)	148 (3759)	145 (3683)	53 (1646)	45 (1143)	10	8
E3009	C2609	140 (3556)	132 (3353)	140 (3556)	91 (2235)	52 (1321)	52 (1321)	41 (1041)	25 (635)	113 (2870)	111 (2819)	56 (1422)	48 (1219)	10	8

Note: See notes on page 60.

**Figure 22, WSC 079/087, 300 to 600 Tons (1050 to 2110 kW)**

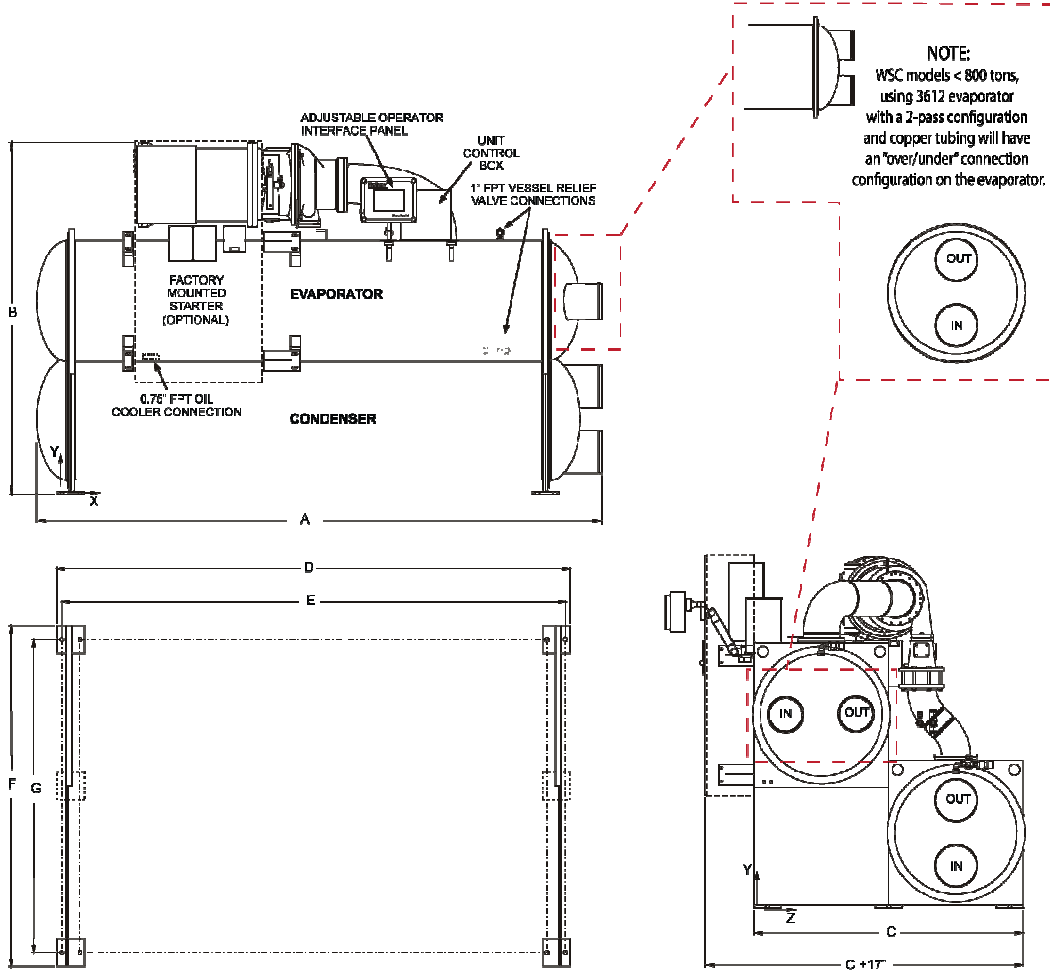

VESSEL CODE		"A" OVERALL LENGTH			OVERALL HEIGHT	OVERALL WIDTH W/O STARTER	CENTER OF GRAVITY			FOOTPRINT				CONNECTIONS	
EVAP	COND	1&3 PASS	2 PASS	HEAD CONN. BOTH ENDS			X	Y	Z	D	E	F	G	EVAP 2 PASS	COND 2 PASS
		A	A	A	B	C									
E2209	C2209	134 (3404)	129 (3277)	134 (3404)	74 (1880)	45 (1143)	50 (1270)	35 (889)	18 (457)	113 (2870)	111 (2819)	45 (1173)	37 (9398)	8	8
E2212	C2212	169 (4293)	164 (4166)	169 (4293)	74 (1880)	45 (1143)	68 (1727)	34 (864)	18 (457)	148 (3759)	145 (3683)	45 (1173)	37 (9398)	8	8
E2609	C2209	134 (3404)	129 (3277)	134 (3404)	78 (1981)	49 (1245)	51 (1295)	40 (1016)	22 (559)	113 (2870)	111 (2819)	49 (1245)	41 (1041)	8	8
E2612	C2212	169 (4293)	164 (4166)	169 (4293)	78 (1981)	49 (1245)	69 (1753)	35 (889)	21 (533)	148 (3759)	145 (3683)	49 (1245)	41 (1041)	8	8
E2609	C2609	134 (3404)	129 (3277)	134 (3404)	83 (2108)	52 (1321)	51 (1295)	37 (940)	21 (533)	113 (2870)	111 (2819)	52 (1321)	44 (1118)	8	8
E2612	C2612	169 (4293)	164 (4166)	169 (4293)	83 (2108)	52 (1321)	69 (1753)	38 (965)	22 (559)	148 (3759)	145 (3683)	52 (1321)	44 (1118)	8	8
E3009	C2609	140 (3556)	132 (3353)	140 (3556)	88 (2235)	56 (1422)	52 (1321)	41 (1041)	25 (635)	113 (2870)	111 (2819)	56 (1422)	48 (1219)	10	8
E3009	C3009	140 (3556)	132 (3353)	140 (3556)	93 (2362)	58 (1473)	52 (1321)	43 (1092)	26 (660)	113 (2870)	111 (2819)	58 (1473)	50 (1270)	10	10
E3012	C2612	175 (4445)	167 (4242)	175 (4445)	88 (2235)	56 (1422)	69 (1753)	40 (1016)	25 (635)	148 (3759)	145 (3683)	56 (1422)	48 (1219)	10	8
E3012	C3012	175 (4445)	167 (4242)	175 (4445)	93 (2362)	58 (1473)	70 (1778)	41 (1041)	26 (660)	148 (3759)	145 (3683)	58 (1473)	50 (1270)	10	10
E3609	C3009	140 (3556)	133 (3378)	140 (3556)	94 (2388)	74 (1880)	52 (1321)	43 (1092)	34 (864)	113 (2870)	111 (2819)	74 (1880)	66 (1676)	12	10
E3612	C3012	175 (4445)	168 (4267)	175 (4445)	94 (2388)	74 (1880)	70 (1778)	41 (1041)	34 (864)	148 (3759)	145 (3683)	74 (1879)	66 (1676)	12	10
E3612	C3612	175 (4445)	168 (4267)	175 (4445)	105 (2667)	80 (2032)	70 (1778)	46 (1168)	38 (965)	148 (3759)	145 (3683)	80 (2032)	72 (1829)	12	12

Notes:

1. E3612/C3612 combination is available on WSC 087 only.
2. E2209/C2209 and E2212/C2212 available on WSC 079 only.
3. See notes on page 60.

Figure 23, WSC 100-113-126, 600 to 1250 Tons (2100 to 4400 kW)

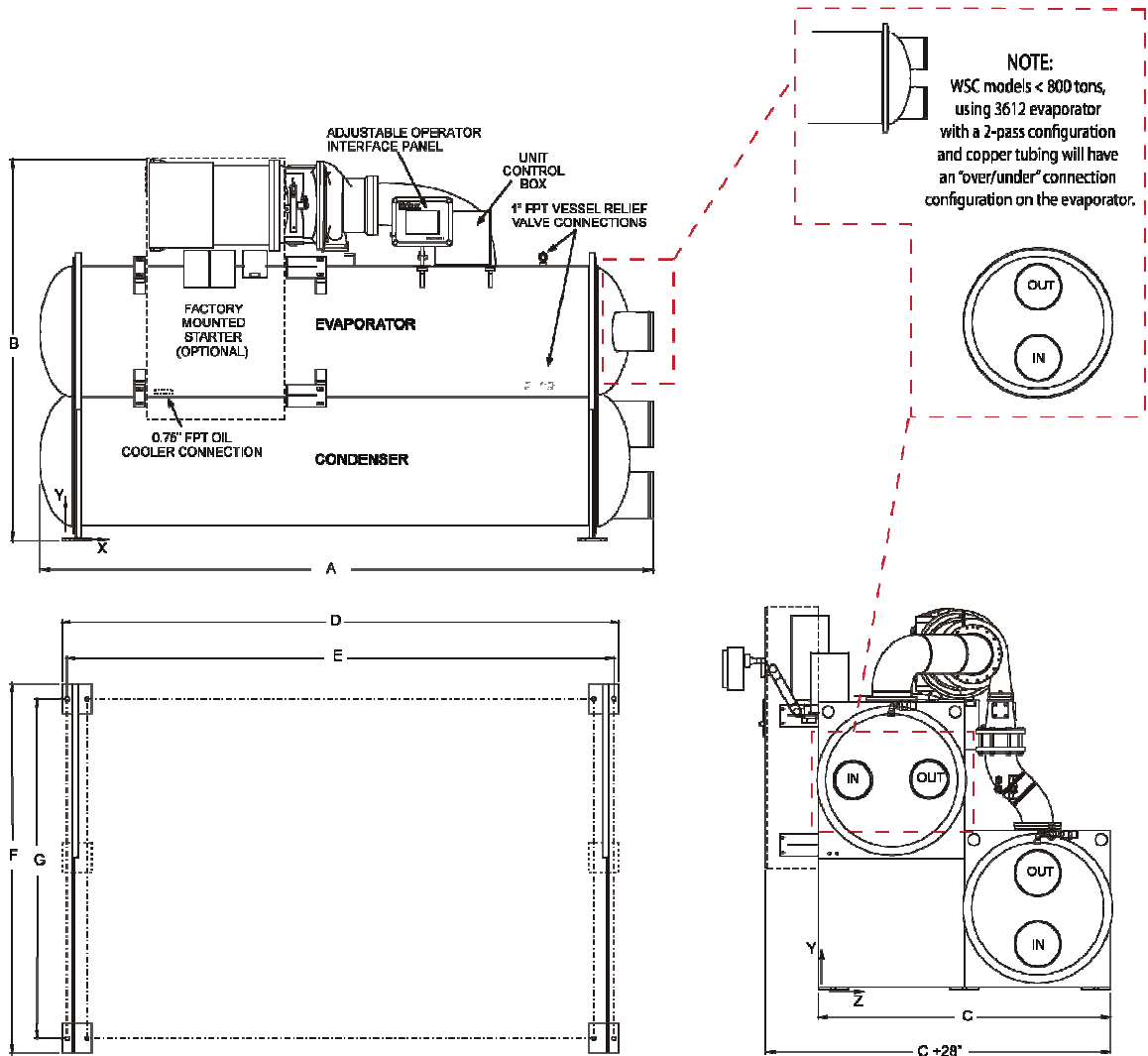

VESSEL CODE		OVERALL LENGTH			OVERALL HEIGHT	OVERALL WIDTH W/O STARTER	CENTER OF GRAVITY			FOOTPRINT				CONNECTIONS (NOTE 3)	
EVAP	COND	1&3 PASS	2 PASS	HEAD CONN BOTH ENDS			X	Y	Z	D	E	F	G	EVAP 2 PASS	COND 2 PASS
		A	A	A	B	C									
E3012	C3012	175 (4445)	167 (4242)	175 (4445)	97 (2464)	61 (1549)	65 (1651)	47 (1194)	21 (553)	148 (3759)	145 (3683)	61 (1549)	53 (1346)	10	10
E3612	C3012	175 (4445)	168 (4267)	175 (4445)	99 (2515)	74 (1880)	68 (1727)	47 (1194)	27 (686)	148 (3759)	145 (3683)	74 (1880)	66 (1676)	12	10
E3612	C3612	175 (4445)	168 (4267)	175 (4445)	99 (2515)	80 (2032)	68 (1727)	46 (1168)	31 (787)	148 (3759)	145 (3683)	80 (2032)	72 (1829)	12	12
E4212	C3612	175 (4445)	170 (4318)	175 (4445)	99 (2515)	86 (2184)	69 (1753)	45 (1143)	35 (889)	148 (3759)	145 (3683)	86 (2184)	78 (1981)	14	12
E4212	C4212	175 (4445)	170 (4318)	175 (4445)	102 (2591)	92 (2337)	69 (1753)	45 (1143)	37 (940)	148 (3759)	145 (3683)	92 (2337)	84 (2134)	14	14
E4812	C4212	181 (4597)	175 (4445)	181 (4597)	106 (2692)	98 (2489)	69 (1753)	46 (1168)	42 (1067)	148 (3759)	145 (3683)	98 (2489)	90 (2286)	18	14
E4812	C4812	181 (4597)	175 (4445)	181 (4597)	106 (2692)	104 (2642)	70 (1778)	46 (1168)	46 (1168)	145 (3683)	145 (3683)	104 (2642)	96 (2438)	18	18

Notes:

1. The optional unit-mounted starter is shipped separate for field mounting, brackets and interconnecting cables are shipped with the unit.
2. E3012/C3012 available on 100 only, E4812/C4812 available on 126 only.
3. Victaulic connections 14-inch and larger are AWWA C-606. Field piping using the AGS groove system will require a field-supplied transition.
4. See notes on page 60.

**Figure 24, WDC 063, 400 to 600 tons (1400 to 2100 kW)**

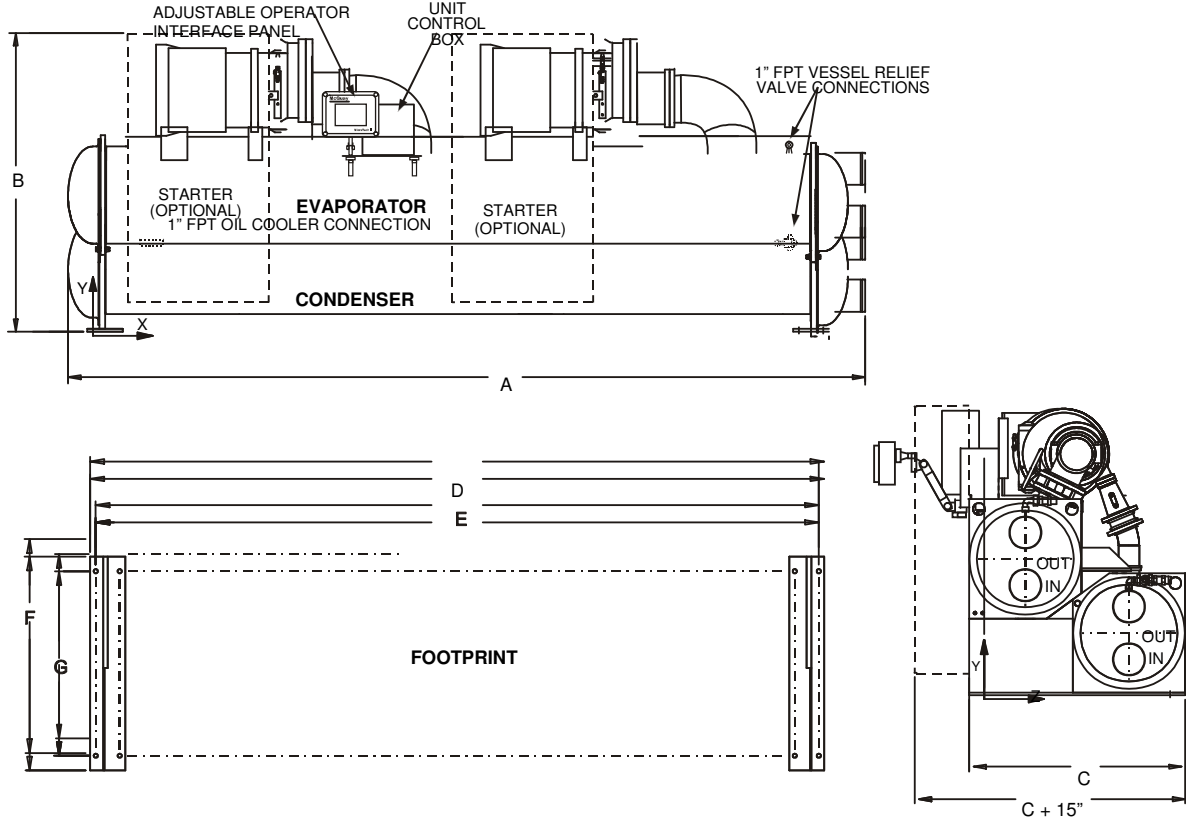

VESSEL CODE		OVERALL LENGTH			OVERALL HEIGHT	OVERALL WIDTH W/O STARTER	CENTER OF GRAVITY			FOOTPRINT				CONNECTIONS	
EVAP	COND	1&3 PASS	2 PASS	HEAD CONN .BOTH ENDS			X	Y	Z	D	E	F	G	EVAP 2 PASS	COND 2 PASS
		A	A	A	B	C									
E2416	C2416	218 (5544)	214 (5426)	218 (5544)	80 (2032)	58 (1470)	91 (2318)	36 (911)	17 (425)	199 (5048)	196 (4972)	58 (1470)	50 (1267)	8	8
E2416	C2616	218 (5544)	214 (5426)	218 (5544)	80 (2032)	58 (1470)	91 (2324)	35 (895)	17½ (438)	199 (5048)	196 (4972)	58 (1470)	50 (1267)	8	8
E2616	C2416	218 (5544)	214 (5426)	218 (5544)	80 (2032)	58 (1470)	91 (2324)	36 (911)	16 (419)	199 (5048)	196 (4972)	58 (1470)	50 (1267)	8	8
E2616	C2616	218 (5544)	214 (5426)	218 (5544)	80 (2032)	58 (1470)	92 (2340)	35 (899)	17 (435)	199 (5048)	196 (4972)	58 (1470)	50 (1267)	8	8
E3016	C3016	221 (5623)	214 (5445)	221 (5623)	90 (2280)	64 (1619)	95 (2410)	40 (1029)	21 (537)	199 (5048)	196 (4972)	64 (1619)	56 (1416)	10	10
E3616	C3016	224 (5685)	218 (5518)	224 (5685)	99 (2496)	71 (1808)	(2)	(2)	(2)	199 (5048)	196 (4972)	71 (1808)	63 (1605)	12	10
E3616	C3616	224 (5685)	218 (5518)	224 (5685)	106 (2686)	75 (1886)	(2)	(2)	(2)	199 (5048)	196 (4972)	75 (1886)	67 (1682)	12	12

Notes:

1. Additional starter width for E3616/C3616 and E3616/C3016 is 4 inches rather than the 15 inches show in drawing.
2. Consult McQuay sales office.
3. See notes on page 60.



**Figure 25, WDC 079 and WDC 087, 600 to 1200 tons (2100 to 4220 kW)**

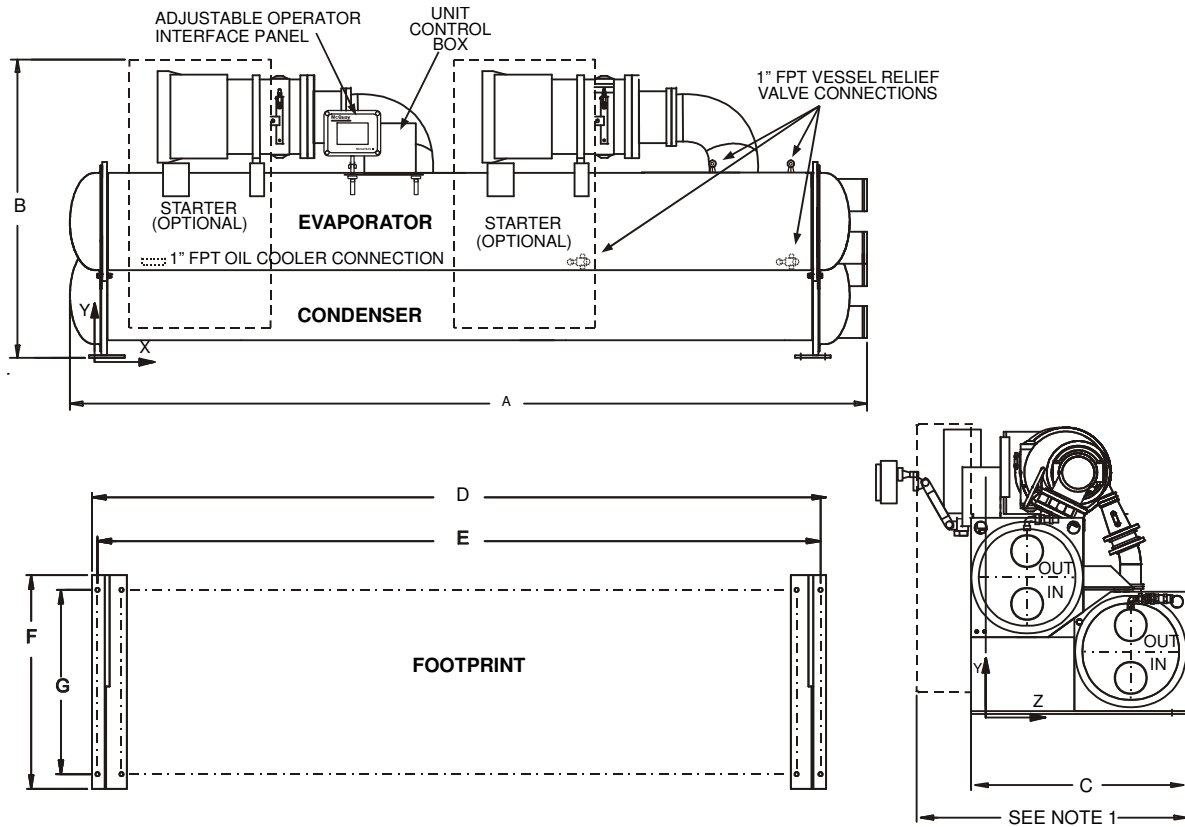

VESSEL CODE		OVERALL LENGTH			OVERALL HEIGHT	OVERALL WIDTH W/O STARTER	CENTER OF GRAVITY			FOOTPRINT				CONNECTIONS	
EVAP	COND	1&3 PASS	2 PASS	HEAD CONN BOTH ENDS			X	Y	Z	D	E	F	G	EVAP 2 PASS	COND 2 PASS
		A	A	A	B	C									
E3016	C3016	221 (5620)	214 (5442)	221 (5620)	94 (2407)	57 (1454)	93 (2369)	44 (1127)	19 (492)	199 (5050)	196 (4974)	57 (1453)	49 (1250)	10	10
E3616	C3016	224 (5696)	218 (5531)	224 (5696)	100 (2530)	71 (1808)	94 (2388)	45 (1149)	32 (803)	199 (5050)	196 (4974)	57 (1453)	49 (1250)	12	10
E3616	C3616	224 (5698)	218 (5531)	224 (5698)	106 (2686)	74 (1886)	94 (2392)	48 (1232)	32 (822)	199 (5050)	196 (4974)	74 (1886)	66 (1682)	12	12
E4216	C4216	224 (5698)	219 (5556)	224 (5698)	100 (2530)	93 (2343)	97 (2458)	44 (1127)	47 (1172)	199 (5050)	196 (4974)	93 (2343)	89 (2241)	14	14

Note:

- See notes on page 60.
- Victaulic connections 14-inch and larger are AWWA C-606. Field piping using the AGS groove system will require a field-supplied transition.

**Figure 26, WDC 100, 1200 to 1700 tons, (4200 to 5950 kW), 16 foot shells  
WDC 113, 1400 to 1900 tons, (4900 to 6700 kW), 16 foot shells  
WDC 126, 1600 to 2700 tons, (5600 to 9450 kW), 16 foot shells**

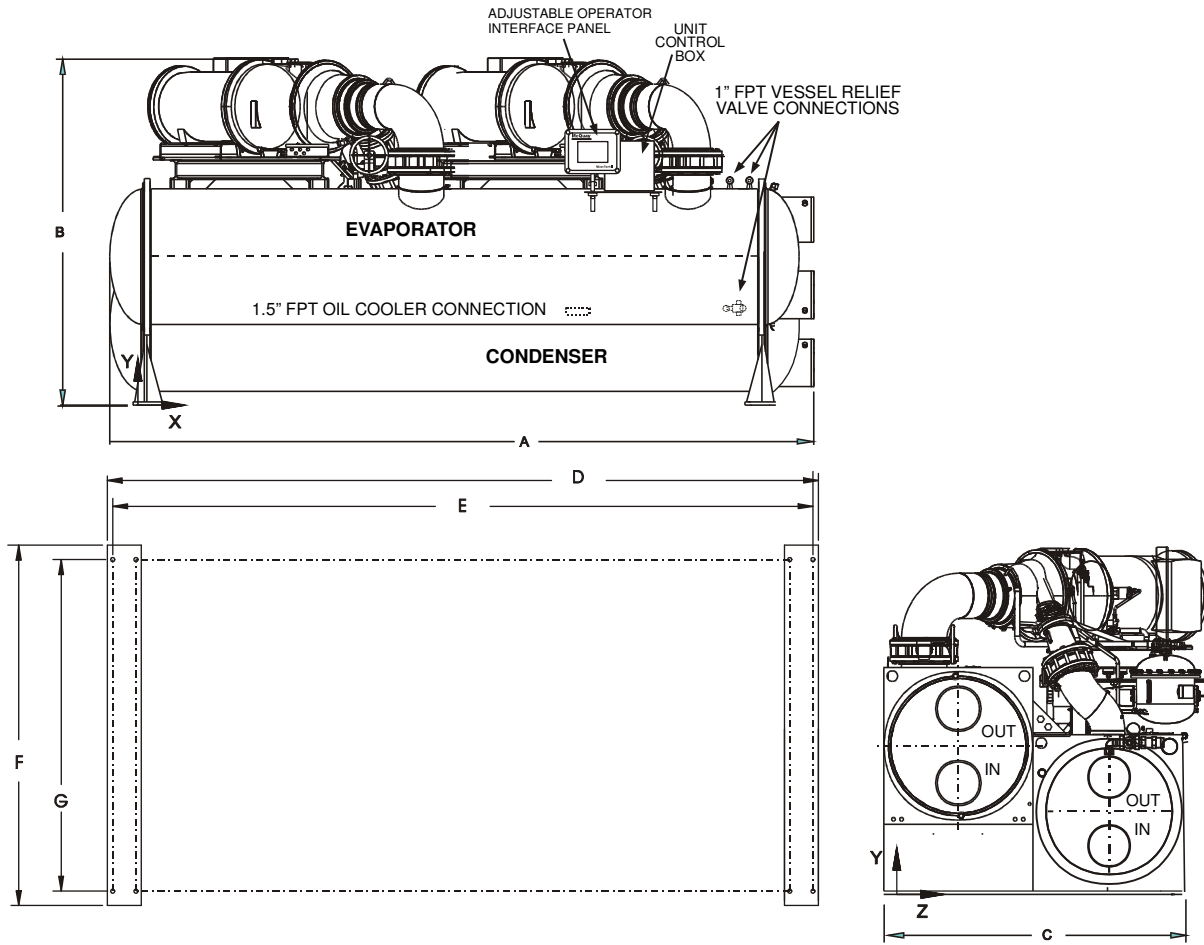

VESSEL CODE		OVERALL LENGTH			OVERALL HEIGHT	OVERALL WIDTH W/O STARTER	CENTER OF GRAVITY W/O STARTER			FOOTPRINT				CONNECTIONS	
EVAP	COND	1&3 PASS	2 PASS	HEAD CONN BOTH ENDS			X	Y	Z	D	E	F	G	EVAP 2 PASS	COND 2 PASS
		A	A	A	B	C									
E3616	C3616	224 (5692)	218 (5528)	224 (5692)	104 (2652)	95 (2419)	93 (2353)	51 (1292)	40 (1003)	199 (5050)	196 (4974)	95 (2419)	87 (2216)	12	12
E4216	C4216	224 (5692)	219 (5554)	224 (5692)	107 (2722)	100 (2545)	94 (2381)	50 (1254)	44 (1105)	199 (5050)	196 (4974)	100 (2545)	92 (2342)	14	16
E4816	C4816	230 (5848)	224 (5703)	230 (5848)	116 (2956)	110 (2792)	95 (2400)	52 (1318)	51 (1292)	199 (5050)	196 (4974)	110 (2792)	102 (2589)	18	18

**Notes:**

1. E3616/C3616 is available on WDC 100 only.
2. Victaulic connections 14-inch and larger are AWWA C-606. Field piping using the AGS groove system will require a field-supplied transition.
3. See notes on page 60.

**Figure 27, WDC 100, 1200 to 1700 tons, (4200 to 5950 kW), 20 foot shells  
WDC 113, 1400 to 1900 tons, (4900 to 6700 kW), 20 foot shells  
WDC 126, 1600 to 2700 tons, (5600 to 9450 kW), 20 foot shells**

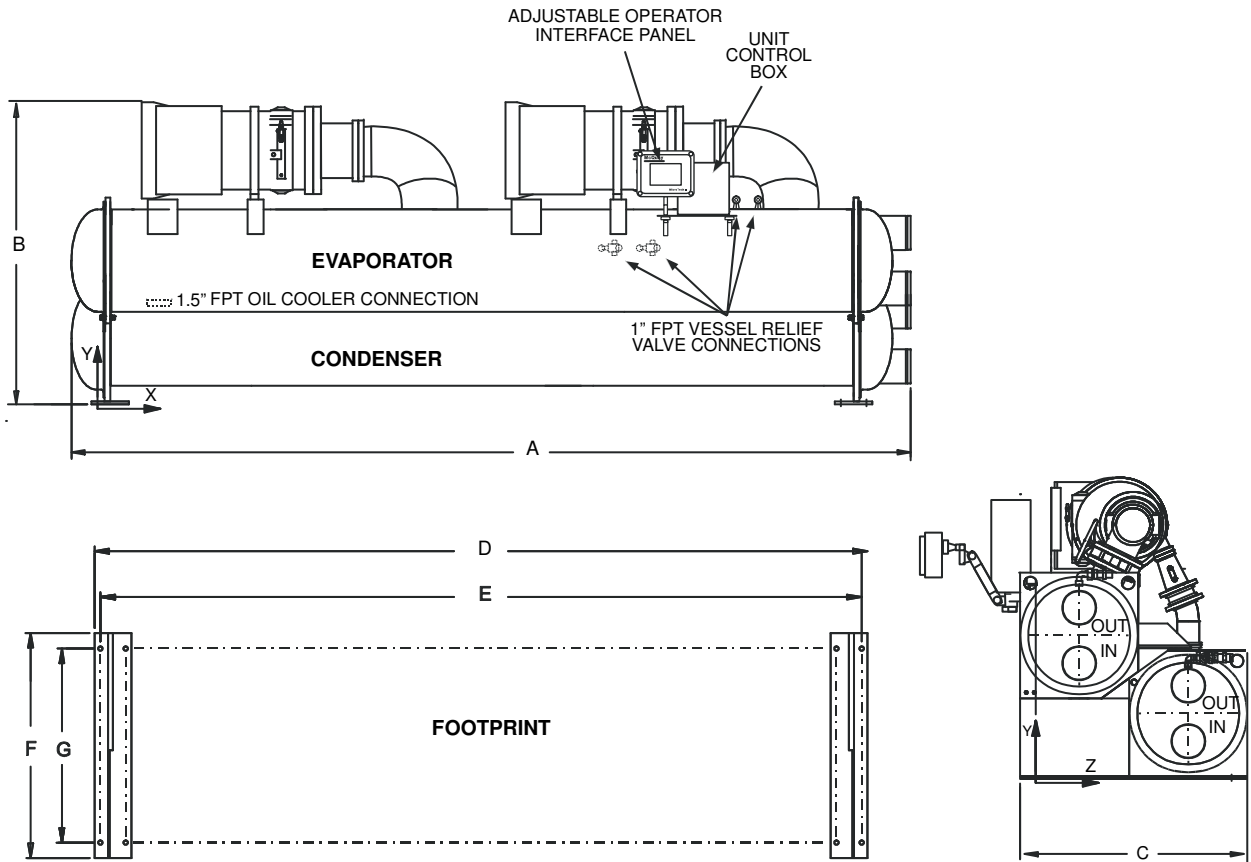

VESSEL CODE		OVERALL LENGTH			OVERALL HEIGHT	OVERALL WIDTH W/O STARTER	CENTER OF GRAVITY			FOOTPRINT				CONNECTIONS	
EVAP	COND	1&3 PASS	2 PASS	HEAD CONN BOTH ENDS			X	Y	Z	D	E	F	G	EVAP 2 PASS	COND 2 PASS
E4220	C4220	272 (6909)	267 (6772)	272 (6909)	102 (2591)	92 (2343)	117 (2991)	46 (1165)	36 (921)	247 (6269)	244 (6193)	92 (2343)	84 (2140)	14	16
E4820	C4820	276 (7010)	271 (6890)	276 (7010)	111 (2810)	104 (2648)	118 (3007)	49 (1238)	43 (1105)	247 (6269)	244 (6193)	104 (2648)	96 (2444)	18	18

Note:

1. Dimensions in inches and (millimeters)
2. Victaulic connections 14-inch and larger are AWWA C-606. Field piping using the AGS groove system will require a field-supplied transition.
3. See notes on page 60.

**Figure 28, WCC 100, 113, 126, 1200 to 2700 tons (4220 to 9450 kW)**

Additional tables and notes are located on page 70.

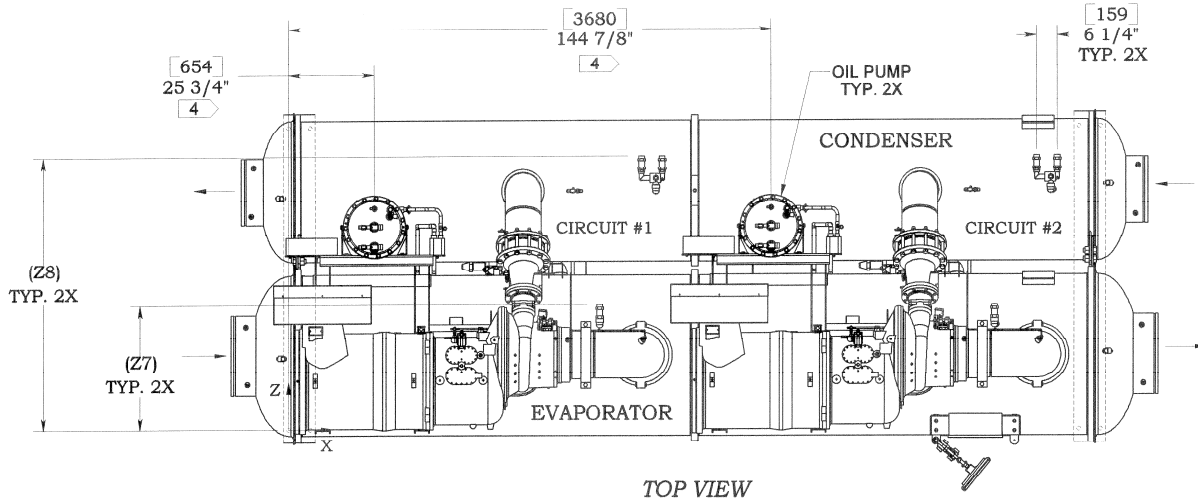

TOP VIEW

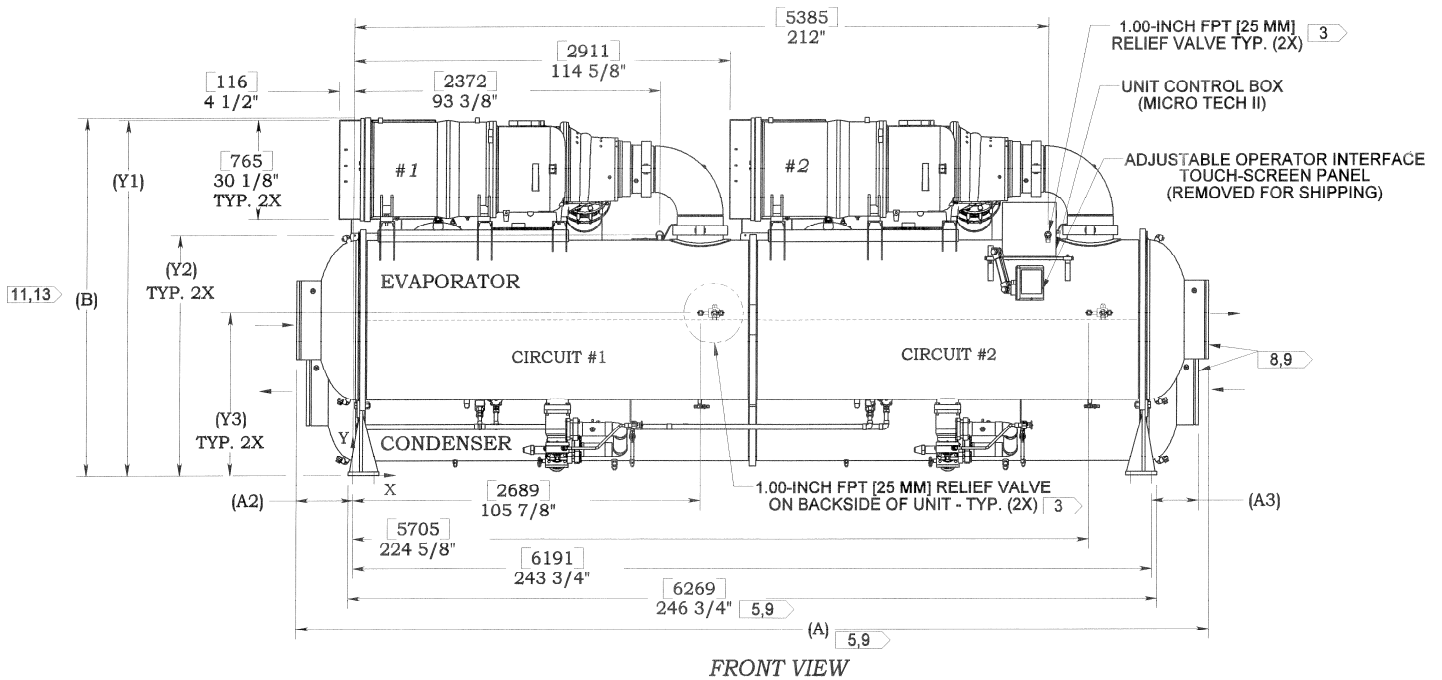

FRONT VIEW

EVAP	COND	OVERALL LENGTH		OVERALL UNIT HEIGHT B	OVERALL WIDTH W/O STARTERS C	WIDTH MTG. HOLES ON FOOT C1	CENTER OF GRAVITY (SHIPPING)			CENTER OF GRAVITY (OPERATING)		
		1 PASS EVAP A	1 PASS COND A1				X	Y	Z	X	Y	Z
E3620	C3620	272 1/4 (6915)	272 1/4 (6915)	100 3/8 (2550)	80 1/4 (2038)	72 1/4 (1835)	115 (2921)	48 3/4 (1238)	30 1/2 (775)	115 3/4 (2940)	47 1/4 (1200)	30 7/8 (784)
E4220	C3620	272 1/4 (6915)	272 1/4 (6915)	101 7/8 (2588)	86 1/4 (2191)	78 1/4 (1988)	115 3/4 (2940)	47 1/2 (1207)	34 1/8 (867)	116 1/2 (2959)	46 1/8 (1172)	34 1/8 (867)
E4220	C4220	272 1/4 (6915)	272 1/4 (6915)	104 5/8 (2658)	92 1/4 (2343)	84 1/4 (2140)	116 1/4 (2953)	48 (1219)	38 (965)	117 1/4 (2978)	45 7/8 (1165)	38 3/4 (984)
E4820	C4220	278 1/4 (7068)	272 1/4 (6915)	108 1/4 (2750)	98 1/4 (2496)	90 1/4 (2292)	116 3/4 (2965)	49 (1245)	40 3/4 (1035)	117 1/2 (2985)	47 1/2 (1207)	40 7/8 (1038)
E4820	C4820	278 1/4 (7068)	278 1/4 (7068)	110 3/8 (2804)	104 1/4 (2648)	96 1/4 (2445)	117 3/8 (2981)	48 7/8 (1241)	45 1/2 (1156)	118 (2997)	47 3/8 (1203)	45 5/8 (1159)

NOTE: Dimensions in inches and (millimeters). See notes on page 60.

### Figure 29, WCC Head Connection Dimensions

Additional tables and notes are located on page 70.

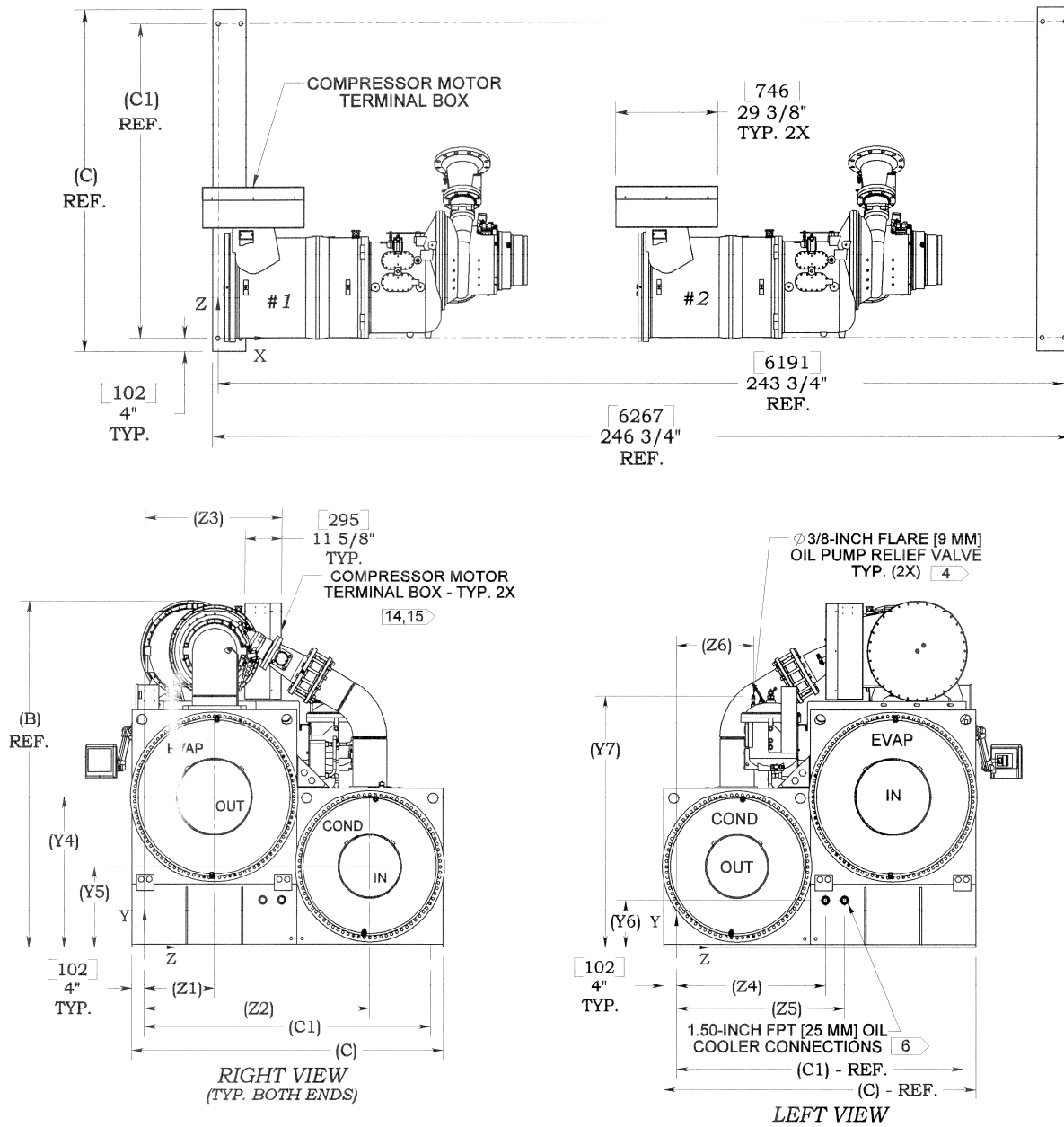

EVAP	COND	EVAPORATOR HEADS				CONDENSER HEADS			
		CONNECTIONS 1 PASS	A2	Y4	Z1	CONNECTIONS 1 PASS	A3	Y5	Z2
E3620	C3620	16.00 (406)	14 1/4 (362)	46 1/8 (1172)	16 (406)	16.00 (406)	14 1/4 (362)	22 1/2 (572)	56 1/8 (1426)
E4220	C3620	20.00 (508)	14 1/4 (362)	43 1/8 (1096)	19 (483)	16.00 (406)	14 1/4 (362)	22 1/2 (572)	62 1/8 (1578)
E4220	C4220	20.00 (508)	14 1/4 (362)	45 7/8 (1165)	19 (483)	20.00 (508)	14 1/4 (362)	25 1/4 (641)	65 1/8 (1654)
E4820	C4220	24.00 (610)	17 1/4 (438)	46 7/8 (1191)	22 (559)	20.00 (508)	14 1/4 (362)	25 1/4 (641)	71 1/8 (1807)
E4820	C4820	24.00 (610)	17 1/4 (438)	49 (1245)	22 (559)	24.00 (610)	17 1/4 (438)	28 1/4 (718)	74 1/8 (1883)

**NOTE:**

- Dimensions in inches and (millimeters)
- Victaulic connections 14-inch and larger are AWWA C-606. Field piping using the AGS groove system will require a field supplied transition.

## WCC Additional Dimension Tables and Notes

**Table 14, Relief Valves, Oil Cooler Connections, Terminal Box, Dimensions**

EVAP	COND	EVAP RELIEF VALVES		COND RELIEF VALVES		OIL PUMP RELIEF VALVES		OIL COOLER CONNECTIONS				COMPRESSOR TERMINAL BOX	
		BOTH CIRCUITS		BOTH CIRCUITS		BOTH CIRCUITS		INLET	OUTLET	INLET	OUTLET	Y1	Z3
		Y2	Z7	Y3	Z8	Y7	Z6	Y6	Y6	Z4	Z5		
E3620	C3620	66 5/8 (1692)	28 (711)	43 (1092)	66 3/8 (1686)	72 3/4 (1848)	15 1/4 (387)	19 3/4 (502)	19 3/4 (502)	40 7/8 (1038)	46 7/8 (1191)	99 3/4 (2534)	37.25 (946)
E4220	C3620	65 3/4 (1670)	33 1/8 (841)	43 (1092)	72 5/8 (1845)	72 1/8 (1832)	18 1/8 (460)	14 (356)	14 (356)	40 7/8 (1038)	46 7/8 (1191)	101 1/8 (2569)	40 1/4 (1022)
E4220	C4220	68 1/2 (1740)	33 1/8 (841)	48 3/4 (1238)	75 5/8 (1921)	74 7/8 (1902)	24 1/8 (613)	16 3/4 (425)	16 3/4 (425)	46 7/8 (1191)	52 7/8 (1343)	103 7/8 (2638)	40 1/4 (1022)
E4820	C4220	72 3/8 (1838)	37 1/8 (943)	48 7/8 (1241)	81 5/8 (2073)	78 1/2 (1994)	24 1/4 (616)	14 3/4 (375)	14 3/4 (375)	46 7/8 (1191)	52 7/8 (1343)	107 1/2 (2731)	43 3/4 (1111)
E4820	C4820	74 3/8 (1889)	37 1/8 (943)	54 3/4 (1391)	84 5/8 (2149)	80 1/2 (2045)	30 1/4 (768)	16 7/8 (429)	16 7/8 (429)	52 7/8 (1343)	58 7/8 (1495)	109 5/8 (2784)	43 1/4 (1099)

**Table 15, Corner Weights**

EVAP	COND	CORNER WEIGHTS - LBS (KG)		
		CORNER	SHIP	OPERAT.
E3620	C3620	LF (LEFT FRONT)	11600.0 (5262)	12852.8 (5830)
		LB (LEFT BACK)	8455.9 (3836)	9600.1 (4355)
		RF (RIGHT FRONT)	10368.3 (4703)	11633.9 (5277)
		RB (RIGHT BACK)	7558.1 (3428)	8689.7 (3942)
E4220	C3620	LF (LEFT FRONT)	12319.7 (5588)	13913.3 (6311)
		LB (LEFT BACK)	9550.8 (4332)	10774.2 (4887)
		RF (RIGHT FRONT)	11126.5 (5047)	12719.6 (5770)
		RB (RIGHT BACK)	8625.7 (3913)	9849.8 (4468)
E4220	C4220	LF (LEFT FRONT)	13138.1 (5959)	15579.0 (7067)
		LB (LEFT BACK)	10784.7 (4892)	13283.2 (6025)
		RF (RIGHT FRONT)	11976.4 (5432)	14437.5 (6549)
		RB (RIGHT BACK)	9831.2 (4459)	12310.0 (5584)
E4820	C4220	LF (LEFT FRONT)	14338.0 (6504)	16545.8 (7505)
		LB (LEFT BACK)	11828.1 (5365)	13711.4 (6219)
		RF (RIGHT FRONT)	13179.5 (5978)	15389.8 (6981)
		RB (RIGHT BACK)	10872.4 (4932)	12753.5 (5785)
E4820	C4820	LF (LEFT FRONT)	15452.3 (7009)	17989.8 (8160)
		LB (LEFT BACK)	13823.4 (6270)	16225.3 (7360)
		RF (RIGHT FRONT)	14336.1 (6503)	16878.1 (7656)
		RB (RIGHT BACK)	12824.8 (5817)	15222.6 (6905)

### Notes

- All dimensions are in inches and [millimeters].
- Final connections must allow for .500 inch [12.7mm] manufacturing tolerances.
- 1.00-inch FPT [25.4 mm] evaporator and condenser relief valves must be piped per ANSI / ASHRAE 15. Number of relief valves is 2 per evaporator (1 each circuit) and 4 per condenser (2 each circuit connected by a two-way valve).
- .375 inch [9 mm] oil pump relief valve, 1 per oil pump must be piped per ANSI / ASHRAE 15.
- 20 feet is required at either end of the tube sheet for tube maintenance. 3 feet [914 mm] is recommended on all other sides and top for service clearance.
- 1.50-inch FPT [38 mm] oil cooler water connections.
- 3.25-inch [95 mm] diameter lifting holes are provided. See installation manual for lifting instructions.
- Evaporator and condenser water connections are given in standard U.S. pipe sizes. Standard connections are suitable for welding or victaulic couplings.
- Standard 1 pass heads with victaulic connections are shown on both the evaporator and condenser. Units with flanged connections add .500 [12.7 mm] at each end for the overall unit length. Standard flanges are ANSI Class 150.
- Dimensions shown are for units (evaporator / condenser) with standard design pressures. The refrigerant side design pressure is 200 PSI {1380 kPa} and the waterside design pressure is 150 PSI {1034 kPa}. Consult the factory for unit dimensions with higher design pressures.
- Vibrator Isolator pads are provided for field installation - .250 inches [6 mm] thick when fully loaded.
- The shipping skid when used adds 4.00 inches [105 mm] to the overall unit height.
- If main power wiring is brought up through the floor, this wiring must be outside the envelope of the unit.
- Typical wiring hookup to the compressor is either the top or bottom of the compressor terminal box
- The units pump down capacity is determined in accordance with ANSI / ASHRAE 15 for the maximum tube count.
- The unit control panel/touch screen side is the "FRONT" of the unit. "RIGHT" and "LEFT" are determined looking at the front.
- The unit is shipped with an operating charge of lubricant and refrigerant.
- Victaulic connections 14-inch and larger are AWWA C-606. Field piping using the AGS groove system will require a field supplied transition.

# Marine Water Boxes (WSC/WCC)

Marine water boxes are an available option on all evaporator and condenser sizes. Epoxy coating of the water boxes and clad tube sheets are available for extreme duty applications.

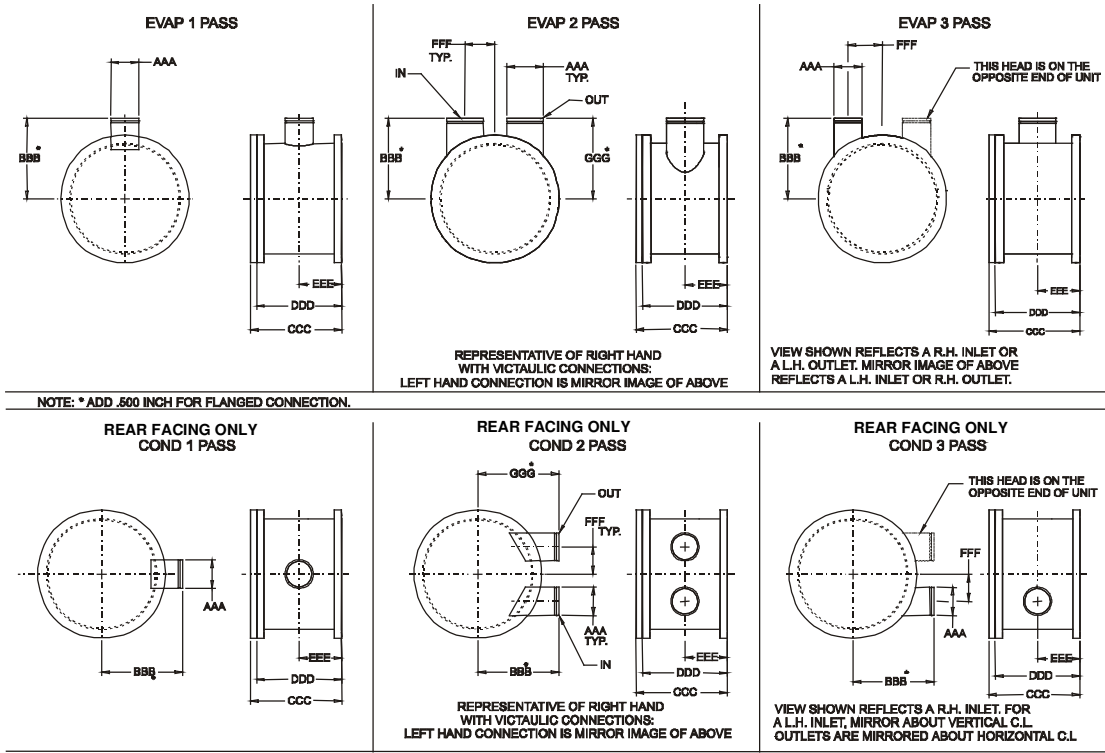

\*Marine Water Box dimensions for WSC models < 800 tons, using 3612 evaporator with a 2-pass configuration and copper tubing (evaporator will have an "over/under" connection configuration)

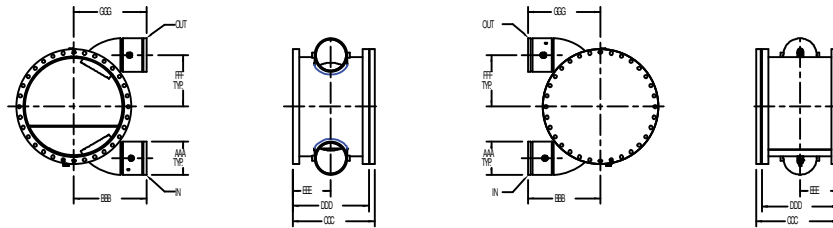

Dimensions with Victaulic or Flanged Connections (150 PSI Non-ASME - Victaulic Connection)

Evap. Dia.	1 PASS					2 PASS						3 PASS						
	'AAA'	'BBB'	'CCC'	'DDD'	'EEE'	'AAA'	'BBB'	'CCC'	'DDD'	'EEE'	'FFF'	'GGG'	'AAA'	'BBB'	'CCC'	'DDD'	'EEE'	'FFF'
E18	8.625	15.00	19.25	18.00	9.00	6.625	15.00	19.00	18.00	9.00	4.78	21.00	4.500	15.00	19.25	18.00	9.00	5.85
E20	8.625	16.00	19.25	18.00	9.00	6.625	16.00	19.00	18.00	9.00	5.63	16.00	4.500	16.00	19.25	18.00	9.00	6.69
E22	10.750	17.00	21.25	20.00	10.00	8.625	17.00	21.00	20.00	10.00	5.59	23.00	5.563	17.00	21.25	20.00	10.00	7.12
E26	10.750	19.00	21.25	20.00	10.00	8.625	19.00	21.25	20.00	10.00	7.07	19.00	6.625	19.00	21.25	20.00	10.00	8.07
E30	14.000	21.00	28.50	26.50	13.25	10.750	21.00	28.50	26.50	13.25	8.13	21.00	6.625	21.00	28.50	26.50	13.25	10.19
E36	16.000	24.00	29.50	28.00	14.00	12.750	24.00	29.50	28.00	14.00	9.75	24.00	8.625	24.00	29.50	28.00	14.00	11.81
E36*	16.000	24.00	29.50	28.00	14.00	12.750	25.00	29.50	28.00	14.00	19.54	25.00	8.625	24.00	29.50	28.00	14.00	11.81
E42	20.000	27.00	34.75	33.00	16.50	14.000	27.00	34.75	33.00	16.50	11.63	27.00	10.750	27.00	34.75	33.00	16.50	13.25
E48	24.000	30.00	38.50	36.50	18.25	18.000	30.00	38.50	36.50	18.25	12.50	36.00	12.750	30.00	38.50	36.50	18.25	15.13
Cond. Dia.	1 PASS					2 PASS						3 PASS						
	'AAA'	'BBB'	'CCC'	'DDD'	'EEE'	'AAA'	'BBB'	'CCC'	'DDD'	'EEE'	'FFF'	'GGG'	'AAA'	'BBB'	'CCC'	'DDD'	'EEE'	'FFF'
C16	8.625	14.00	15.25	14.00	7.00	5.563	14.00	15.00	14.00	7.00	4.35	14.00	Consult local sales office					
C18	8.625	15.00	19.25	18.00	9.00	6.625	15.00	19.00	18.00	9.00	4.78	15.00						
C20	8.625	16.00	19.25	18.00	9.00	6.625	16.00	19.00	18.00	9.00	5.63	16.00						
C22	10.750	17.00	21.25	20.00	10.00	8.625	17.00	21.00	20.00	10.00	5.59	23.00						
C26	10.750	19.00	21.25	20.00	10.00	8.625	19.00	21.25	20.00	10.00	7.07	19.00						
C30	14.000	21.00	28.50	26.50	13.25	10.750	21.00	28.50	26.50	13.25	8.13	21.00						
C36	16.000	24.00	30.25	28.00	14.00	12.750	24.00	30.25	28.00	14.00	9.75	24.00						
C42	20.000	27.00	32.50	30.00	15.00	14.000	27.00	32.50	30.00	15.00	11.63	27.00						
C48	24.000	30.00	39.5	36.00	18.25	18.000	30.00	39.5	36.50	18.25	12.50	36.50						

See Notes on Next Page.

# Marine Water Boxes (WDC)

**FIGURE 1**

2 and 4 Pass Cond. (Except 18 in. 2 Pass)

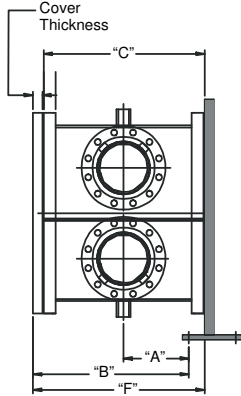

**FIGURE 2**

Evap. And Cond. 1 Pass

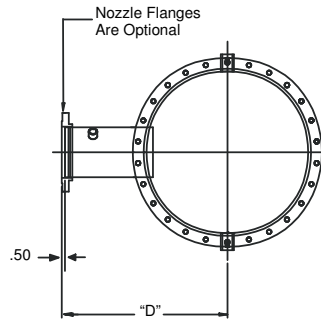

**FIGURE 3**

2 and 4 Pass Cond. (Except 18 in. 2 Pass)

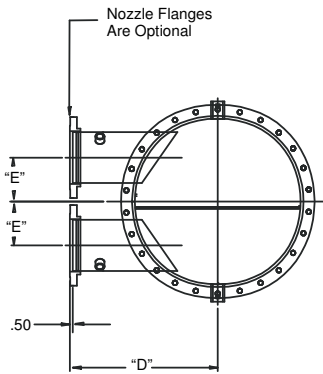

**FIGURE 4**

All 2 Pass Evap. - All 3 Pass Cond.  
18 in. 2 Pass Cond.

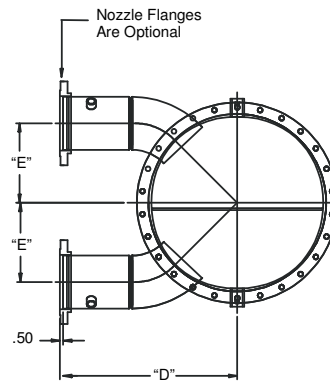

**Note:** Evaporator connections are front facing only; Condenser connections are rear facing only.

Shell O.D.	Vessel	Outline Dimensions									Cover Thickness	Connections			
		A	B	C	D			E		F		Pipe Size For Passes			
					Fig 2	Fig 3	Fig 4	Fig 3	Fig 4			1P	2P	3P	4P
16	Evap	5	13.00	14.00	14.50	-----	22.50	-----	6.94	15.00	1.00	8	5	4	4
	Cond	5	13.00	14.00	14.50	16.50	22.50	4.35	6.94	15.00					
18	Evap	7	17.25	18.00	22.50	-----	22.50	-----	7.94	19.25	1.25	8	6	5	4
	Cond	7	17.25	18.00	16.50	-----	22.50	-----	7.06	19.25					
20	Evap	7	17.25	18.00	22.50	-----	22.50	-----	7.88	19.25	1.25	8	6	5	4
22	Evap	8	19.50	20.00	22.50	-----	22.50	-----	10.12	21.50	1.50	10	8	6	5
	Cond	8	19.50	20.00	22.50	22.50	22.50	5.62	9.93	21.50					
26	Evap	8	19.50	20.00	22.50	-----	22.50	-----	11.69	21.50	1.50	10	8	8	6
	Cond	8	19.50	20.00	22.50	22.50	22.50	7.07	11.69	21.50					
30	Evap	12	27.75	28.00	24.50	-----	24.50	-----	13.62	29.75	1.75	14	10	8	8
	Cond	12	27.75	28.00	27.50	27.50	27.50	8.12	13.00	29.75					
36	Evap	12	28.00	28.00	27.50	-----	27.50	-----	16.50	30.00	2.00	16	12	10	8
	Cond	12	28.00	28.00	27.50	27.50	27.50	9.75	16.33	30.00					
36*	Evap	12	28.00	28.00	-----	-----	25.50	-----	19.54	30.00	2.00	16	12	10	8
	Cond	12	28.00	28.00	27.50	27.50	27.50	9.75	16.33	30.00					
42	Evap	13	30.50	30.00	27.50	-----	35.50	-----	19.38	33.00	2.00	20	16	12	10
	Cond	13	30.50	30.00	27.50	27.50	27.50	11.63	11.63	33.00					
48	Evap	---	-----	36.00	36.00	-----	40.00	-----	22.64	39.25	2.75	---	18	---	---
	Cond	---	-----	36.00	36.00	36.00	-----	11.50	-----	39.25					

**Notes:**

1. Dimensions in inches (mm).
2. Flanges are ANSI raised face. Mating flanges by others.
3. Some condensers with flanges can have staggered connections due to flange interference. Consult factory.
4. Flanges add 0.5 inches to the distance from the vertical centerline to the flange faces than shown with Victaulic couplings.
5. Victaulic connections 14-inch and larger are AWWA C-606. Field piping using the AGS groove system will requires a field-supplied transition.
6. \*Applies specifically to models under 800 tons with a 2-pass configuration, copper tubing and utilizing E3612 evaporator.



# Supplemental Publications

---

McQuay has a large number of publications and software applications relating to centrifugal chillers and to chilled water systems. The latest versions are available on [www.mcquay.com](http://www.mcquay.com) or from the local McQuay sales office. Some of the available material is listed below:

## Catalogs/Manuals

- CAT Templifier - a catalog with detailed information on the capacities and application of Templifier™ Heat Pump Water Heaters.
- CAT Starter - a catalog with detailed information on unit mounted and freestanding starters for McQuay centrifugal chillers. It contains descriptions, dimensions, lug sizes and other valuable information.
- IM 1044 - the installation and maintenance manual for centrifugal chillers.
- OM CentrifMicro II - details operation of the unit MicroTech control system.
- IOMM-Starter - provides installation and operating information on centrifugal starters.
- IOMM VFD - provides installation and operating information on centrifugal VFDs.

## Application Guides

- AG 31-002 - Centrifugal Chiller Fundamentals, a 20 page general guide, discussing compressor theory, vessel design and pass optimization, capacity control, prime movers and dual compressor chillers.
- AG 31-003 - Chiller Plant Design, a 94 page comprehensive guide on designing chilled water plants. Some of the subjects included are water temperatures and ranges, parallel versus series flow, primary/secondary systems, free cooling, heat recovery.
- AG 31-007 - Refrigerant Application Guide, discusses refrigerant chemistry, specific refrigerant characteristics, phase-outs, substitutes, and what the future holds.

## Application Bulletins

- Application Bulletin, Issue No 1 - Centrifugal Chillers with VFDs, discusses speed/lift relationships, condenser water relief, and applying VFDs.
- Application Bulletin, Issue No 4 - Overview of ASHRAE Standard 90.1-1999, summarizes HVAC equipment efficiency requirements.

## MicroTech II Controls

- IM 735 - installation manual for LONWORKS communication module on chillers.
- IM 906 - installation manual for BACnet MSTP communication module on chillers.
- IM 837 - installation manual for BACnet IP communication module on chillers.
- IM 743 - installation manual for Modbus communication module on chillers.

## Software

- Energy Analyzer™ - gives fast answers, with life cycle analysis, for optimizing chiller plant type and terminal equipment.
- Acoustic Analyzer™ - with known equipment sound levels, this program will provide sound levels at various distances, with various wall configurations, giving total site results.

## SECTION 15XXX CENTRIFUGAL CHILLERS SINGLE COMPRESSOR

### PART 1 — GENERAL

#### 1.1 SUMMARY

Section includes design, performance criteria, refrigerants, controls, and installation requirements for water-cooled centrifugal chillers.

#### 1.2 REFERENCES

Comply with the following codes and standards

ARI 550/590	NEC
ANSI/ASHRAE 15	OSHA as adopted by the State
	ASME Section VIII

#### 1.3 SUBMITTALS

Submittals shall include the following:

- A. Dimensioned plan and elevation view drawings, including motor starter cabinet, required clearances, and location of all field piping and electrical connections.
- B. Summaries of all auxiliary utility requirements such as: electricity, water, air, etc. Summary shall indicate quality and quantity of each required utility.
- C. Diagram of control system indicating points for field interface and field connection. Diagram shall fully depict field and factory wiring.
- D. Manufacturer's certified performance data at full load plus IPLV or NPLV.
- E. Before shipment, submit a certification of satisfactory completion of factory run test signed by a company officer. The test shall be performed on an ARI Certified test stand and conducted according to ARI Standard 550/590.
- F. Installation and Operating Manuals.

#### 1.4 QUALITY ASSURANCE

- A. Qualifications: Equipment manufacturer must specialize in the manufacture of the products specified and have five years experience with the equipment and refrigerant offered.
- B. Regulatory Requirements: Comply with the codes and standards in Section 1.2.
- C. Chiller manufacturer plant shall be ISO Registered.

#### 1.5 DELIVERY AND HANDLING

- A. Chillers shall be delivered to the job site completely assembled and charged with refrigerant and oil.
- B. Comply with the manufacturer's instructions for rigging and transporting units. Leave protective covers in place until installation.

#### 1.6 WARRANTY

The refrigeration equipment manufacturer's warranty shall be for a period of (one) -- **OR** -- (two) -- **Or**-- (five) years from date of equipment start up or 18 months from shipment whichever occurs first. The warranty shall include parts and labor costs for the repair or replacement of defects in material or workmanship.

#### 1.7 MAINTENANCE

Chiller maintenance shall be the responsibility of the owner with the following exceptions:

- A. The manufacturer shall provide the first year scheduled oil and filter change if required.
- B. The manufacturer shall provide first year purge unit maintenance if required.

**PART 2 — PRODUCTS**

**2.1 ACCEPTABLE MANUFACTURERS**

- A. McQuay International
- B. (Approved Equal)

**2.2 UNIT DESCRIPTION**

Provide and install as shown on the plans a factory-assembled, factory charged water-cooled packaged chiller. Each unit shall be complete with a single-stage hermetic centrifugal compressor with lubrication and control system, factory mounted starter, evaporator, condenser, refrigerant control device and any other components necessary for a complete and operable chiller package.

Each chiller shall be factory run-tested on an AHRI certified test stand with water at job conditions (excluding glycol applications). Operating controls shall be adjusted and checked. The refrigerant charge shall be adjusted for optimum operation and recorded on the unit nameplate. Units operating with 50-Hz power shall be tested with a 50-Hz power supply. Any deviation in performance or operation shall be remedied prior to shipment and the unit retested if necessary to confirm repairs or adjustments.

**2.3 DESIGN REQUIREMENTS**

- A. General: Provide a complete water-cooled hermetic centrifugal compressor water-chilling package as specified herein. Machine shall be provided according to referenced standards Section 1.2. In general, unit shall consist of a compressor, condenser, evaporator, lubrication system, starter and control system.

Note: Chillers shall be charged with a refrigerant such as R-134a, not subject to the Montreal Protocol and the U. S. Clean Air Act.

- B. Performance: Refer to schedule on the drawings. The chiller shall be capable of stable operation to ten percent of full load with standard ARI entering condensing water relief without the use of hot gas bypass.
- C. Acoustics: Sound pressure levels for the complete unit shall not exceed the following specified levels. Provide the necessary acoustic treatment to chiller as required. Sound data shall be measured according to ARI Standard 575-87. Data shall be in dB. Data shall be the highest levels recorded at all load points. Test shall be in accordance with ARI Standard 575.

Octave Band	63	125	250	500	1000	2000	4000	8000	dba
	_____	_____	_____	_____	_____	_____	_____	_____	_____

**2.4 CHILLER COMPONENTS**

- A. Compressor:
  - 1. Unit shall have a single-stage hermetic centrifugal compressor. Casing design shall ensure major wearing parts, main bearings, and thrust bearings are accessible for maintenance and replacement. The lubrication system shall protect machine during coast down period resulting from a loss of electrical power.
  - 2. The impeller shall be statically and dynamically balanced. The compressor shall be vibration tested and not exceed a level of 0.14 IPS.
  - 3. Movable inlet guide vanes actuated by an internal oil pressure driven piston shall accomplish unloading. Compressors using an unloading system that requires penetrations through the compressor housing or linkages, or both that must be lubricated and adjusted are acceptable provided the manufacturer provides a five-year inspection agreement consisting of semi-annual inspection, lubrication, and annual change out of any compressor seals. A statement of inclusion must accompany any quotations.
  - 4. If the compressor is not equipped with guide vanes for each stage and movable discharge diffusers, then furnish hot gas bypass and select chillers at 5% lower kW/ton than specified to compensate for bypass inefficiency at low loads.
  - 5. For open motor units, an oil reservoir shall collect any oil and refrigerant that leaks past the seal. A float device shall be provided to open when the reservoir is full, directing the refrigerant/oil mixture back into the compressor housing.

Manufacturer shall warrant the shaft seal, reservoir, and float valve system against leakage of oil and refrigerant to the outside of the refrigerating unit for a period of 5 years from the initial start-up including parts and labor to replace a defective seal and any refrigerant required to trim the charge original specifications.

- B. Lubrication System: The compressor shall have an independent lubrication system to provide lubrication to all parts requiring oil. Provide a heater in the oil sump to maintain oil at sufficient temperature to minimize affinity of refrigerant, and a thermostatically controlled water-cooled oil cooler. Coolers located inside the evaporator or condenser are not acceptable due to inaccessibility. A positive displacement oil pump shall be powered through the unit control transformer.
- C. Refrigerant Evaporator and Condenser:
1. Evaporator and condenser shall be of the shell-and-tube type, designed, constructed, tested and stamped according to the requirements of the ASME Code, Section VIII. Regardless of the operating pressure, the refrigerant side of each vessel will bear the ASME stamp indicating compliance with the code and indicating a test pressure of 1.1 times the working pressure, but not less than 100 psig. Provide intermediate tube supports at a maximum of 24 inch spacing.
  2. Tubes shall be enhanced for maximum heat transfer, rolled into steel tube sheets and sealed with Locktite® or equal sealer. The tubes shall be individually replaceable.
  3. Provide isolation valves and sufficient volume to hold the full refrigerant charge in the condenser or provide a separate pumpout system with storage tank.
  4. The water sides shall be designed for a minimum of 150 psi or as specified elsewhere. Vents and drains shall be provided.
  5. Evaporator minimum refrigerant temperature shall be 33°F.
  6. An electronic or thermal refrigerant expansion valve shall control refrigerant flow to the evaporator. Fixed orifice devices or float controls with hot gas bypass are not acceptable because of inefficient control at low load conditions. The liquid line shall have a moisture indicating sight glass.
  7. The evaporator and condenser shall be separate shells. A single shell containing both vessel functions is not acceptable because of the possibility of internal leaks.
  8. Reseating type spring loaded pressure relief valves according to ASHRAE-15 safety code shall be furnished. The evaporator shall be provided with single or multiple valves. The condenser shall be provided with dual relief valves equipped with a transfer valve so one valve can be removed for testing or replacement without loss of refrigerant or removal of refrigerant from the vessel. Rupture disks are not acceptable.
  9. The evaporator, suction line, and any other component or part of a component subject to condensing moisture shall be insulated with UL recognized 3/4 inch closed cell insulation. All joints and seams shall be carefully sealed to form a vapor barrier.
  10. Provide factory-mounted thermal dispersion flow switches on each vessel to prevent unit operation with no flow.
- D. Prime Mover: Squirrel cage induction motor of the hermetic type of sufficient size to efficiently fulfill compressor horsepower requirements. Motor shall be liquid refrigerant cooled with internal thermal overload protection devices embedded in the winding of each phase. Motor shall be compatible with the starting method specified hereinafter. If the Contractor chooses to provided an open drive motor or compressor, verify in the submittal that the scheduled chiller room ventilation system will accommodate the additional heat and maintain the equipment room at design indoor temperature based on 95°F outdoor ambient ventilation air available.
- If additional cooling is required, manufacturer shall be responsible for the installation, wiring and controls of a cooling system. Chiller selection shall compensate for tonnage and efficiency loss to make certain the owner is not penalized.
- E. Motor Starter:
1. The main motor starter is to be factory mounted and fully wired to the chiller components and factory tested during the run test of the unit.

-- OR --

The main motor starter is to be furnished by the chiller manufacturer and shipped loose for floor mounting and field wiring to the chiller package. It shall be free-standing with NEMA-1 enclosure designed for top entry and bottom exit and with front access.

2. For open drive air-cooled motors the chiller manufacturer shall be responsible for providing the cooling of the refrigeration machinery room. The sensible cooling load shall be based on the total heat rejection to the atmosphere from the refrigeration units.
3. The starter must comply with the codes and standards in Section 1.2.
4. **Low Voltage (200 through 600 volts)** controllers are to be continuous duty AC magnetic type constructed according to NEMA standards for Industrial Controls and Systems (ICS) and capable of carrying the specified current on a continuous basis. The starters shall be:

Solid-State Reduced Voltage - Starters shall be furnished with silicon controlled rectifiers (SCR) connected for starting and include a bypass contactor. When operating speed is reached, the bypass contactor shall be energized removing the SCRs from the circuit during normal running.

**-- OR --**

Wye-Delta Closed Transition - The starter s shall be equipped with properly sized resistors to provide a smooth transition. The resistors shall be protected with a transition resistor protector, tripping in a maximum of two seconds, locking out the starter, and shall be manually reset. A clearly marked transition timer shall be adjustable from 0 to 30 seconds or a current sensing devise shall initiate transition when starting current drops to 90% of RLA.

- a) All starters shall be coordinated with the chiller package(s) making certain all terminals are properly marked according to the chiller manufacturer's wiring diagrams.
- b) The starters shall be equipped with redundant motor control relays (MCR). The relays shall interconnect the starters with the unit control panels and directly operate the main motor contactors. The MCRs shall constitute the only means of energizing the motor starter.
- c) The main contactors shall have a normally open and a normally closed auxiliary contact rated at 125VA pilot duty at 115 VAC. An additional set of normally open contacts shall be provided for each MCR.
- d) There shall be electronic overloads in each phase which will permit continuous operation at 107% of the rated load amps of each motor. The overloads shall have a must-trip setting at 125% of the RLA. Overloads shall be manual reset and shall de-energize the main contactors when the overcurrent occurs. The overloads shall be adjustable and selected for mid-range. Overloads shall be adjustable, manual reset, ambient compensated, and set for class 10 operation.
- e) Each starter shall have a current transformer and adjustable voltage dropping resistor(s) to supply a 5.0 VAC signal at full load to the unit control panels.
- f) Each starter shall be equipped with a line to 115 VAC control transformer, fused in both the primary and secondary, to supply power to the control panels, oil heaters and oil pumps.
- g) Each starter shall include phase failure, phase undervoltage and phase reversal protection.

**-OR-**

Variable Frequency Drive

- a) The chiller shall be equipped with a Variable Frequency Drives (VFD) to automatically regulate each compressor speed in response to cooling load and compressor pressure lift. The chiller control shall coordinate compressor speed and guide vane position to optimize chiller efficiency.
- b) A digital regulator shall provide V/Hz control.

- c) The VFD shall have 110% continuous overload of continuous amp rating with no time limit, PWM (pulse width modulated) output, IGBT (insulated gate bipolar transistors) power technology and full power rating at 2kHz..
- d) All heat producing devices shall be contained in a single heatsink with single inlet and out connections for the connection of chilled water. When factory mounted on the chiller package, the water connections shall be piped and leak tested at the factory.

**-OR-**

**4. Medium Voltage (601 through 7200 volts).** The starter shall be:

**Solid-State Reduced Voltage** - Starter shall be furnished with silicon controlled rectifiers (SCR) connected for starting and include a bypass contactor. When operating speed is reached, the bypass contactor shall be energized removing the SCRs from the circuit during normal running.

- a) The starter shall be coordinated with the chiller package(s) making certain all terminals are properly marked according to the chiller manufacturer's wiring diagrams.
- b) The starters shall be equipped with redundant motor control relays (MCR). The relays shall interconnect the starters with the unit control panels and directly operate the main motor contactors. The MCRs shall constitute the only means of energizing the motor contacts.
- c) The main contactors shall have a normally open auxiliary contact rated at 125VA pilot duty at 115 VAC. An additional set of normally open contacts shall be provided on the MCR.
- d) There shall be electronic overloads in each phase set at 107% of the rated load amps of each motor. Overloads shall be manual reset and shall de-energize the main contactors when the overcurrent occurs. The overloads shall be adjustable and selected for mid-range. Overloads shall be adjusted for a locked rotor trip time of 8 seconds at full voltage and must trip in 60 seconds or less at reduced voltage (33% of delta LRA).
- e) Each starter shall have a current transformer and adjustable voltage dropping resistor(s) to supply a 5.0 VAC signal at full load to the unit control panels.
- f) Each starter shall be equipped with a line-to-115 VAC control transformer, fused in both the primary and secondary, to supply power to the control panels, oil heaters and oil pumps.
- g) Each starter shall include phase under/over voltage protection, phase failure and reversal protection, a load break disconnect switch and current limiting power fuses

**--OR--**

**Across-the-Line** type with primary contactor allowing locked rotor amps to reach the motor when energized and including items 1 through 7 above

**--OR--**

**Autotransformer** type factory wired to the 65% tap with drawout magnetic, three-pole, vacuum break shorting contactor, drawout magnetic, two-pole, vacuum break starting contactor, and open delta starting auto-transformer factory set at 65% and including items 1 through 7 above with a isolating safety switch in lieu of a load-break disconnect switch.

**--OR--**

**Primary Reactor** type with drawout magnetic, three-pole, vacuum break shorting assembly, and three-phase starting reactor, factory set at the 65% tap and including items 1 through 7 above with a isolating safety switch in lieu of a load-break disconnect switch.

All medium and high voltage starters shall have the following components:

#### **Main Control Relays**

A motor control relay shall be provided to interlock the starter with the chiller. The relay shall constitute the only means of energizing the motor starter. No other devices (manual or automatic) with the capability of energizing the starter can be used. The starter is to be controlled by the unit microprocessor.

#### **Motor Protection and Overloads**

The starter shall include overload protection functions. These controls include:

- Solid state overload (overcurrent) protection
- Phase unbalance protection
- Phase reversal and phase loss protection.
- Adjustable overload to closely match motor performance
- Three current transformers to measure motor current and a fourth current transformer for input to the chiller microprocessor.

#### **Undervoltage (UV) Relay**

The undervoltage relay is an adjustable three-phase protection system that is activated when the voltage falls below a predetermined safe value and is factory set at 85% of nominal.

#### **Control Voltage Transformer**

The starter is to be provided with a 3KVA control transformer with both secondary and primary fuses to supply control power to the chiller.

#### **Additional Standard Components**

- Mechanical type solderless connectors to handle wire sizes indicated by NEC.
- Three isolated vertical line contactors
- Three-pole, gang operated non-load break isolating switch
- Three vertically mounted current limiting power fuse blocks (fuses included)
- Magnetic three-pole, vacuum break contactor
- Single phase control circuit transformer
- Vertically mounted control circuit primary current limiting fuses
- Current transformers
- Control circuit terminal blocks and secondary fuses
- Phase failure and reversal relay

#### **G. Chiller Controller**

The chiller shall have distributed control consisting of a unit controller, a compressor controller and a 15-inch super VGA color touch screen for operator interface with the control system.

The touch screen shall have graphics clearly depicting the chiller status, operating data, including water temperatures, percent RLA, water setpoint, alarm status and have STOP and AUTO control buttons.

The operator interface touch screen shall have inherent trend logging capabilities, which are transferable to other PC management systems such as an Excel spreadsheet via a USB port. Active trend logging data shall be available for viewing in 20 minute, 2 hour or 8 hour intervals. A full 24 hours of history is downloadable via a USB port. The following trended parameters shall be displayed:

- Entering and leaving chilled water temps
- Entering and leaving condenser water temps
- Evaporator saturated refrigerant pressure
- Condenser saturated refrigerant pressure
- Net oil pressure
- % rated load amps

In addition to the trended items above, other real-time operating parameters are also shown on the touch screen. These items can be displayed in two ways: by chiller graphic showing each component or from a color-coded, bar chart format. At a minimum, the following critical areas must be monitored:

- Oil sump temperature
- Oil feed line temperature
- Evaporator saturated refrigerant temperature
- Suction temperature
- Condenser saturated refrigerant temperature
- Discharge temperature
- Liquid line temperature

Unit setpoints shall be viewable on screens and changeable after insertion of a password.

Complete unit operating and maintenance instructions shall be viewable on the touch screen and be downloadable via an onboard USB port.

Automatic corrective action to reduce unnecessary cycling shall be accomplished through pre-emptive control of low evaporator or high discharge pressure conditions to keep the unit operating through ancillary transient conditions.

System specific, chiller plant architecture software shall be employed to display the chiller, piping, pumps and cooling tower. Chiller plant optimization software for up to 3 chillers shall also be included to provide automatic control of: evaporator and condenser pumps (primary and standby), up to 4 stages of cooling tower fans and a cooling tower modulating bypass valve and/or cooling tower fan variable frequency drives. There shall be five possible tower control strategies:

- Tower fan staging only – up to 4 stages controlled by either the entering condenser water temperature or lift differential temperature between the condenser and evaporator saturated temperatures.
- Tower fan staging plus low limit - controlled as in # 1 plus tower bypass valve set at a minimum entering condenser water temperature
- Tower staging with staged bypass control – similar to # 2 with additional control of the bypass valve between fan staging to smooth control and minimize fan staging.
- VFD staging only – in this mode, a variable speed drive controls the first fan with up to 3 more fans to be staged on and off and there is no bypass valve.
- VFD and Valve Staging – same as # 4 plus bypass valve control

Factory mounted DDC controller(s) shall support operation on a BACnet®, Modbus® or LONMARKS® network via one of the data link / physical layers listed below as specified by the successful Building Automation System (BAS) supplier.

- BACnet MS/TP master (Clause 9)
- BACnet IP, (Annex J)
- BACnet ISO 8802-3, (Ethernet)
- LONMARKS FTT-10A. The unit controller shall be LONMARKS® certified.

The information communicated between the BAS and the factory mounted unit controllers shall include the reading and writing of data to allow unit monitoring, control and alarm notification as specified in the unit sequence of operation and the unit points list.

eXternal Interface File (XIF) shall be provided with the chiller submittal data.

All communication from the chiller unit controller as specified in the points list shall be via standard BACnet objects. Proprietary BACnet objects shall not be allowed. BACnet communications shall conform to the BACnet protocol (ANSI/ASHRAE135-2001). A BACnet Protocol Implementation Conformance Statement (PICS) shall be provided along with the unit submittal.



## 2.5. MISCELLANEOUS ITEMS

- A. Pumpout System: The unit shall be equipped with a pumpout system complete with a transfer pump, condensing unit, and storage vessel constructed according to ASME Code for Unfired Pressure Vessels and shall bear the National Board stamp. If the design of the unit allows the charge to be transferred to and isolated in the main condenser, then a pumpout system is not required. Transfer of refrigerant charge shall be accomplished by either main compressor operation, migration, or gravity flow. Isolation shall be accomplished with valves located at the inlet and outlet of the condenser. The main condenser shall be sized to contain the refrigerant charge at 90°F according to ANSI-ASHRAE 15.A.
- B. Purge System (Negative Pressure Chillers Only):
  - 1. The chiller manufacturer shall provide a separate high efficiency purge system that operates independently of the unit and can be operated while the unit is off. The system shall consist of an air-cooled condensing unit, purge condensing tank, pumpout compressor and control system.
  - 2. A dedicated condensing unit shall be provided with the purge system to provide a cooling source whether or not the chiller is running. The condensing unit shall provide a low purge coil temperature to result in a maximum loss of 0.1 pounds of refrigerant per pound of purged air.
  - 3. The purge tank shall consist of a cooling coil, filter-drier cores, water separation tube, sight glass, drain, and air discharge port. Air and water are separated from the refrigerant vapor and accumulated in the purge tank.
  - 4. The pumpout system shall consist of a small compressor and a restriction device located at the pumpout compressor suction connection.
  - 5. The purge unit shall be connected to a 100% reclaim device.
- C. Vacuum Prevention System (negative pressure chillers only): Chiller manufacturer shall supply and install a vacuum prevention system for each chiller. The system shall constantly maintain 0.05 psig inside the vessel during non-operational periods. The system shall consist of a precision pressure controller, two silicon blanket heaters, a pressure transducer, and solid-state safety circuit.
- D. Refrigerant Detection Device (negative pressure chillers only): Chiller manufacturer shall supply and install a refrigerant detection device and alarm capable of monitoring refrigerant at a level of 10 ppm. Due to the critical nature of this device and possible owner liability, the chiller manufacturer shall guarantee and maintain the detection monitor for five years after owner acceptance of the system.
- E. Waffle type vibration pads for field mounting under unit feet.

## **PART 3 — EXECUTION**

### 3.1 INSTALLATION

- A. Install according to manufacturer's requirements, shop drawings, and Contract Documents.
- B. Adjust chiller alignment on concrete foundations, sole plates or subbases as called for on drawings.
- C. Arrange the piping on each vessel to allow for dismantling the pipe to permit head removal and tube cleaning.
- D. Furnish and install necessary auxiliary water piping for oil cooler.
- E. Coordinate electrical installation with electrical contractor.
- F. Coordinate controls with control contractor.
- G. Provide all materiel required to ensure a fully operational and functional chiller.

### 3.2 START-UP

- A. Units shall be factory charged with the proper refrigerant and oil.
- B. Factory Start-Up Services: The manufacturer shall provide factory authorized supervision for as long a time as is necessary to ensure proper operation of the unit, but in no case for less than two full working days. During the period of start-up, the start-up technician shall instruct the owner's representative in proper care and operation of the unit.

# SECTION 15XXX CENTRIFUGAL CHILLERS DUAL COMPRESSOR

## PART 1 — GENERAL

### 1.1 SUMMARY

Section includes design, performance criteria, refrigerants, controls, and installation requirements for water-cooled centrifugal chillers.

### 1.02 REFERENCES

Comply with the following codes and standards

ARI 550/590	NEC
ANSI/ASHRAE 15	OSHA as adopted by the State
	ASME Section VIII

### 1.3 SUBMITTALS

Submittals shall include the following:

- A. Dimensioned plan and elevation view Drawings, including motor starter cabinet, required clearances, and location of all field piping and electrical connections.
- B. Summaries of all auxiliary utility requirements such as: electricity, water, air, etc. Summary shall indicate quality and quantity of each required utility.
- C. Diagram of control system indicating points for field interface and field connection. Diagram shall fully depict field and factory wiring.
- D. Manufacturer's certified performance data at full load plus IPLV or NPLV.
- E. Installation and Operating Manuals.

### 1.4 QUALITY ASSURANCE

- A. Qualifications: Equipment manufacturer must specialize in the manufacture of the products specified and have five years experience with the equipment and refrigerant offered.
- B. Regulatory Requirements: Comply with the codes and standards in Section 1.2.
- C. Chiller manufacturer plant shall be ISO Registered.

### 1.5 DELIVERY AND HANDLING

- A. Chillers shall be delivered to the job site completely assembled and charged with refrigerant and oil.
- B. Comply with the manufacturer's instructions for rigging and transporting units. Leave protective covers in place until installation.

### 1.6 WARRANTY

The refrigeration equipment manufacturer's warranty shall be for a period of (one) -- **Or** -- (two) -- **Or** -- (five) years from date of equipment start or 18 months from shipment whichever occurs first. The warranty shall include parts and labor costs for the repair or replacement of defects in material or workmanship. The refrigerant charge shall be warranted against contamination from a motor burnout for five years.

### 1.7 MAINTENANCE

Maintenance of the chillers shall be the responsibility of the owner with the following exceptions:

- A. The manufacturer shall provide the first year scheduled oil and filter change if required.
- B. The manufacturer shall provide first year purge unit maintenance if required.

## PART 2 — PRODUCTS

### 2.1 ACCEPTABLE MANUFACTURERS

- A. McQuay International
- B. (Approved Equal)

2.2 UNIT DESCRIPTION

Provide and install as shown on the plans a factory assembled, charged water-cooled packaged chiller. Each unit shall be complete with two single-stage hermetic centrifugal compressors each having independent lubrication and control systems, factory mounted starters, and isolation valves. The evaporator, condenser, and refrigerant control device of each unit shall be common to the compressors. The chiller unit shall be capable of running on one compressor with the other compressor or any of its auxiliaries removed.

Each chiller shall be factory run-tested on an AHRI certified test stand with water at job conditions (excluding glycol applications). Operating controls shall be adjusted and checked. The refrigerant charge shall be adjusted for optimum operation and recorded on the unit nameplate. Units operating with 50-Hz power shall be tested with a 50-Hz power supply. Any deviation in performance or operation shall be remedied prior to shipment and the unit retested if necessary to confirm repairs or adjustments.

2.3 DESIGN REQUIREMENTS

A. General: Provide a complete water-cooled dual hermetic compressor centrifugal water chiller as specified herein. Machine shall be provided according to standards, Section 1.2. In general, unit shall consist of two compressors, refrigerant condenser and evaporator, two lubrication systems, two starters and two control systems.

Note: Chillers shall be charged with a refrigerant such as HFC-134a, not subject to the Montreal Protocol and the U. S. Clean Air Act.

B. Performance: Refer to schedule on the drawings. The chiller shall be capable of stable operation to five percent of full load with standard ARI entering condensing water relief without hot gas bypass.

C. Acoustics: Sound pressure for the unit shall not exceed the following specified levels. Provide the necessary acoustic treatment to chiller as required. Sound data shall be measured according to ARI Standard 575-87 and shall be in dB. Data shall be the highest levels recorded at all load points. Test shall be in accordance with ARI Standard 575.

Octave Band

63 125 250 500 1000 2000 4000 8000 dba

\_\_\_\_\_

2.4 CHILLER COMPONENTS

A. Compressors:

- 1. Unit shall have two single-stage hermetic centrifugal compressors. Casing design shall ensure major wearing parts, main bearings and thrust bearings are accessible for maintenance and replacement. Lubrication system shall protect machine during coast down resulting from a loss of power.
2. Impellers shall be statically and dynamically balanced. The compressor shall be vibration tested and not exceed 0.14 IPS.
3. Movable inlet guide vanes actuated by an internal oil pressure driven piston shall accomplish unloading. Compressors using an unloading system that requires penetrations of the compressor housing or linkages, or both, that must be lubricated and adjusted are acceptable provided the manufacturer provides a five-year inspection agreement consisting of semi-annual inspection, lubrication, and annual changeout of compressor seals. A statement of inclusion must accompany any quotations.
4. If compressors are not equipped with guide vanes for each stage and movable discharge diffusers, then furnish hot gas bypass and select chillers at 5% lower kW/ton than specified to compensate for bypass inefficiency at low loads.
5. For open motor unit, an oil reservoir shall collect any oil and refrigerant that leaks past the seal. A float device shall be provided to open when the reservoir is full, directing the refrigerant/oil mixture back into the compressor housing. Manufacturer shall warrant the shaft seal, reservoir, and float valve system against leakage of oil and refrigerant to the outside of the refrigerating unit for a period of 5 years from the initial start-up including parts and labor to replace a defective seal and any refrigerant required to trim the charge original specifications.

- B. Lubrication System: Each compressor shall have an independent lubrication system to provide lubrication to all parts requiring oil. Provide a heater in the oil sump to maintain oil at sufficient temperature to minimize affinity of refrigerant, and a thermostatically controlled water-cooled oil cooler. Coolers located inside the evaporator or condenser are not acceptable due to inaccessibility. A positive displacement submerged oil pump shall be powered through the unit control transformer.
- C. Refrigerant Evaporator and Condenser:
1. The evaporator and condenser shall be single circuit and be of the shell-and-tube type, designed, constructed, tested and stamped according to the requirements of the ASME Code, Section VIII. Regardless of the operating pressure, the refrigerant side of each vessel will bear the ASME stamp indicating compliance with the code and indicating a test pressure of 1.1 times the working pressure but not less than 100 psig. Provide intermediate tube supports at a maximum of 18 inch spacing.
  2. Tubes shall be enhanced for maximum heat transfer, rolled into steel tube sheets and sealed with Locktite or equal sealer. The tubes shall be individually replaceable and secured to the intermediate supports without rolling.
  3. Provide sufficient isolation valves and condenser volume to hold full refrigerant charge in the condenser during servicing or provide a separate pumpout system and storage tank sufficient to hold the charge of the largest unit being furnished.
  4. The water sides shall be designed for a minimum of 150 psig or as specified elsewhere. Vents and drains shall be provided.
  5. Chilled water minimum refrigerant temperature shall be 33°F.
  6. An electronic or thermal refrigerant expansion valve shall control refrigerant flow to the evaporator. Fixed orifice devices or float controls with hot gas bypass are not acceptable because of inefficient control at low load conditions. The liquid line shall have a moisture indicating sight glass.
  7. The evaporator and condenser shall be separate shells. A single shell containing both vessel functions is not acceptable because of the possibility of internal leaks.
  8. Interstage economizers shall be used between each compressor stage for increased efficiency.
  9. Reseating type spring loaded pressure relief valves according to ASHRAE-15 safety code shall be furnished. The evaporator shall be provided with single or multiple valves. The condenser shall be provided with dual relief valves equipped with a transfer valve so one valve can be removed for testing or replacement without loss of refrigerant or removal of refrigerant from the vessel. Rupture disks are not acceptable.
  10. The evaporator, suction line, and any other component or part of a component subject to condensing moisture shall be insulated with UL recognized 3/4 inch closed cell insulation. All joints and seams shall be carefully sealed to form a vapor barrier.
  11. Provide Factory-mounted thermal dispersion flow switches on each vessel to prevent unit operation with no flow, furnished, installed and wired by the contractor.
- D. Prime Mover: Squirrel cage induction motor of the hermetic type of sufficient size to efficiently fulfill compressor horsepower requirements. Motor shall be liquid refrigerant cooled with internal thermal overload protection devices embedded in the winding of each phase. Motor shall be compatible with the starting method specified hereinafter. If the Contractor chooses to provided an open drive motor or compressor, verify in the submittal that the scheduled chiller room ventilation system will accommodate the additional heat and maintain the equipment room at design indoor temperature based on 95°F outdoor ambient ventilation air available.
- If additional cooling is required, manufacturer shall be responsible for the installation, wiring and controls of a cooling system. Chiller selection shall compensate for tons and efficiency loss to make certain the owner is not penalized.
- E. Motor Starter:
1. The main motor starter is to be factory mounted and fully wired to the chiller components and factory tested during the run test of the unit.

-- OR --

The main motor starter is to be furnished by the chiller manufacturer and shipped loose for floor mounting and field wiring to the chiller package. It shall be free-standing with NEMA-1 enclosure designed for top entry and bottom exit and with front access.

2. For open drive air-cooled motors the chiller manufacturer shall be responsible for providing the cooling of the refrigeration machinery room. The sensible cooling load shall be based on the total heat rejection to the atmosphere from the refrigeration units.
3. The starter must comply with the codes and standards in Section 1.2.
4. **Low Voltage (200 through 600 volts)** controllers are to be continuous duty AC magnetic type constructed according to NEMA standards for Industrial Controls and Systems (ICS) and capable of carrying the specified current on a continuous basis. The starters shall be:

Solid-State Reduced Voltage - Starters shall be furnished with silicon controlled rectifiers (SCR) connected for starting and include a bypass contactor. When operating speed is reached, the bypass contactor shall be energized removing the SCRs from the circuit during normal running.

-- OR --

Wye-Delta Closed Transition - The starters shall be equipped with properly sized resistors to provide a smooth transition. The resistors shall be protected with a transition resistor protector, tripping in a maximum of two seconds, locking out the starter, and shall be manually reset. A clearly marked transition timer shall be adjustable from 0 to 30 seconds or a current sensing device shall initiate transition when starting current drops to 90% of RLA.

- a) All starters shall be coordinated with the chiller package(s) making certain all terminals are properly marked according to the chiller manufacturer's wiring diagrams.
- b) The starters shall be equipped with redundant motor control relays (MCR). The relays shall interconnect the starters with the unit control panels and directly operate the main motor contactors. The MCRs shall constitute the only means of energizing the motor starter.
- c) The main contactors shall have a normally open and a normally closed auxiliary contact rated at 125VA pilot duty at 115 VAC. An additional set of normally open contacts shall be provided for each MCR.
- d) There shall be electronic overloads in each phase which will permit continuous operation at 107% of the rated load amps of each motor. The overloads shall have a must-trip setting at 125% of the RLA. Overloads shall be manual reset and shall de-energize the main contactors when the overcurrent occurs. The overloads shall be adjustable and selected for mid-range. Overloads shall be adjustable, manual reset, ambient compensated, and set for class 10 operation.
- e) Each starter shall have a current transformer and adjustable voltage dropping resistor(s) to supply a 5.0 VAC signal at full load to the unit control panels.
- f) Each starter shall be equipped with a line to 115 VAC control transformer, fused in both the primary and secondary, to supply power to the control panels, oil heaters and oil pumps.
- g) Each starter shall include phase failure, phase undervoltage and phase reversal protection.

-OR-

Variable Frequency Drive

- a) The chiller shall be equipped with a Variable Frequency Drives (VFD) to automatically regulate each compressor speed in response to cooling load and compressor pressure lift. The chiller control shall coordinate compressor speed and guide vane position to optimize chiller efficiency.
- b) A digital regulator shall provide V/Hz control.

- c) The VFD shall have 110% continuous overload of continuous amp rating with no time limit, PWM (pulse width modulated) output, IGBT (insulated gate bipolar transistors) power technology and full power rating at 2kHz..
- d) All heat producing devices shall be contained in a single heatsink with single inlet and out connections for the connection of chilled water. When factory mounted on the chiller package, the water connections shall be piped and leak tested at the factory.

**-OR-**

**4. Medium Voltage (601 through 7200 volts).** The starter shall be:

**Solid-State Reduced Voltage** - Starter shall be furnished with silicon controlled rectifiers (SCR) connected for starting and include a bypass contactor. When operating speed is reached, the bypass contactor shall be energized removing the SCRs from the circuit during normal running.

- a) The starter shall be coordinated with the chiller package(s) making certain all terminals are properly marked according to the chiller manufacturer's wiring diagrams.
- b) The starters shall be equipped with redundant motor control relays (MCR). The relays shall interconnect the starters with the unit control panels and directly operate the main motor contactors. The MCRs shall constitute the only means of energizing the motor contacts.
- c) The main contactors shall have a normally open auxiliary contact rated at 125VA pilot duty at 115 VAC. An additional set of normally open contacts shall be provided on the MCR.
- d) There shall be electronic overloads in each phase set at 107% of the rated load amps of each motor. Overloads shall be manual reset and shall de-energize the main contactors when the overcurrent occurs. The overloads shall be adjustable and selected for mid-range. Overloads shall be adjusted for a locked rotor trip time of 8 seconds at full voltage and must trip in 60 seconds or less at reduced voltage (33% of delta LRA).
- e) Each starter shall have a current transformer and adjustable voltage dropping resistor(s) to supply a 5.0 VAC signal at full load to the unit control panels.
- f) Each starter shall be equipped with a line-to-115 VAC control transformer, fused in both the primary and secondary, to supply power to the control panels, oil heaters and oil pumps.
- g) Each starter shall include phase under/over voltage protection, phase failure and reversal protection, a load break disconnect switch and current limiting power fuses

**--OR--**

**Across-the-Line** type with primary contactor allowing locked rotor amps to reach the motor when energized and including items 1 through 7 above

**--OR--**

**Autotransformer** type factory wired to the 65% tap with drawout magnetic, three-pole, vacuum break shorting contactor, drawout magnetic, two-pole, vacuum break starting contactor, and open delta starting auto-transformer factory set at 65% and including items 1 through 7 above with a isolating safety switch in lieu of a load-break disconnect switch.

**--OR--**

**Primary Reactor** type with drawout magnetic, three-pole, vacuum break shorting assembly, and three-phase starting reactor, factory set at the 65% tap and including items 1 through 7 above with a isolating safety switch in lieu of a load-break disconnect switch.

All medium and high voltage starters shall have the following components:

#### **Main Control Relays**

A motor control relay shall be provided to interlock the starter with the chiller. The relay shall constitute the only means of energizing the motor starter. No other devices (manual or automatic) with the capability of energizing the starter can be used. The starter is to be controlled by the unit microprocessor.

#### **Motor Protection and Overloads**

The starter shall include overload protection functions. These controls include:

- Solid state overload (overcurrent) protection
- Phase unbalance protection
- Phase reversal and phase loss protection.
- Adjustable overload to closely match motor performance
- Three current transformers to measure motor current and a fourth current transformer for input to the chiller microprocessor.

#### **Undervoltage (UV) Relay**

The undervoltage relay is an adjustable three-phase protection system that is activated when the voltage falls below a predetermined safe value and is factory set at 85% of nominal.

#### **Control Voltage Transformer**

The starter is to be provided with a 3KVA control transformer with both secondary and primary fuses to supply control power to the chiller.

#### **Additional Standard Components**

- Mechanical type solderless connectors to handle wire sizes indicated by NEC.
- Three isolated vertical line contactors
- Three-pole, gang operated non-load break isolating switch
- Three vertically mounted current limiting power fuse blocks (fuses included)
- Magnetic three-pole, vacuum break contactor
- Single phase control circuit transformer
- Vertically mounted control circuit primary current limiting fuses
- Current transformers
- Control circuit terminal blocks and secondary fuses
- Phase failure and reversal relay

### **G. CHILLER CONTROLLER**

The chiller shall have distributed control consisting of a unit controller, a compressor controller for each compressor and a 15-inch super VGA color touch screen for operator interface with the control system.

The touch screen shall have graphics clearly depicting the chiller status, operating data, including water temperatures, percent RLA, water setpoint, alarm status and have STOP and AUTO control buttons.

The operator interface touch screen shall have inherent trend logging capabilities, which are transferable to other PC management systems such as an Excel spreadsheet via a USB port. Active trend logging data shall be available for viewing in 20 minute, 2 hour or 8 hour intervals. A full 24 hours of history is downloadable via a USB port. The following trended parameters shall be displayed:

- Entering and leaving chilled water temps
- Entering and leaving condenser water temps
- Evaporator saturated refrigerant pressure
- Condenser saturated refrigerant pressure
- Net oil pressure for each compressor
- % rated load amps for entire unit

In addition to the trended items above, other real-time operating parameters are also shown on the touch screen. These items can be displayed in two ways: by chiller graphic showing each component or from a color-coded, bar chart format. At a minimum, the following critical areas must be monitored:

- Oil sump temperature per compressor
- Oil feed line temperature per compressor
- Evaporator saturated refrigerant temperature for unit
- Suction temperature for unit
- Condenser saturated refrigerant temperature for unit
- Discharge temperature for unit
- Liquid line temperature for unit

The unit operating and maintenance instructions shall be viewable on the touch screen and downloadable via an onboard USB port.

Complete fault history shall be displayed using an easy to decipher, color coded set of messages that are date and time stamped. The last 20 faults shall be downloadable from the USB port.

Automatic corrective action to reduce unnecessary cycling shall be accomplished through pre-emptive control of low evaporator or high discharge pressure conditions to keep the unit operating through ancillary transient conditions.

System specific, chiller plant architecture software shall be employed to display the chiller, piping, pumps and cooling tower. Chiller plant optimization software for up to 4 chillers shall also be included to provide automatic control of: evaporator and condenser pumps (primary and standby), up to 4 stages of cooling tower fans and a cooling tower modulating bypass valve or cooling tower variable frequency drives. There shall be five possible tower control strategies:

- Tower fan staging only – up to 4 stages controlled by either the entering condenser water temperature or lift differential temperature between the condenser and evaporator saturated temperatures.
- Tower fan staging plus low limit - controlled as in # 1 plus tower bypass valve set at a minimum entering condenser water temperature.
- Tower staging with staged bypass control – similar to # 2 with additional control of the bypass valve between fan staging to smooth control and minimize fan staging.
- VFD staging only – in this mode, a variable speed drive controls the first fan with up to 3 more fans to be staged on and off and there is no bypass valve.
- VFD and Valve Staging – same as # 4 plus bypass valve control.

Factory mounted DDC controllers shall support operation on a BACnet, Modbus or LONWORKS network via a factory-installed communication module.

Factory mounted DDC controller(s) shall support operation on a BACnet®, Modbus® or LONMARKS® network via one of the data link / physical layers listed below as specified by the successful Building Automation System (BAS) supplier.

- BACnet MS/TP master (Clause 9)
- BACnet IP, (Annex J)
- BACnet ISO 8802-3, (Ethernet)
- LONMARKS FTT-10A. The unit controller shall be LONMARKS® certified.

The information communicated between the BAS and the factory mounted unit controllers shall include the reading and writing of data to allow unit monitoring, control and alarm notification as specified in the unit sequence of operation and the unit points list.

For chillers communicating over a LONMARK network, the corresponding LONMARK eXternal Interface File (XIF) shall be provided with the chiller submittal data.

All communication from the chiller unit controller as specified in the points list shall be via standard BACnet objects. Proprietary BACnet objects shall not be allowed. BACnet communications shall conform to the BACnet protocol (ANSI/ASHRAE135-2001). A BACnet Protocol Implementation Conformance Statement (PICS) shall be provided along with the unit submittal.



## 2.5. MISCELLANEOUS ITEMS

- A. Pumpout System: The unit shall be equipped with a pumpout system complete with a transfer pump, condensing unit, and storage vessel constructed according to ASME Code for Unfired Pressure Vessels and shall bear the National Boards stamp. If the design of the unit allows the charge to be transferred to and isolated in the main condenser, then a pumpout system is not required. Transfer of refrigerant charge shall be accomplished by either main compressor operation, migration, or gravity flow. Isolation shall be accomplished with valves located at the inlet and exit of the condenser. The main condenser shall be sized to contain the refrigerant charge at 90°F according to ANSI-ASHRAE 15.A.
- B. Purge System (negative pressure chillers only):
  - 1. The chiller manufacturer shall provide a separate high efficiency purge system that operates independently of the unit and can be operated while the unit is off. The system shall consist of an air-cooled condensing unit, purge condensing tank, pumpout compressor and control system.
  - 2. A dedicated condensing unit shall be provided with the purge system to provide a cooling source whether or not the chiller is running. The condensing unit shall provide a low purge coil temperature to result in a maximum loss of 0.1 pounds of refrigerant per pound of purged air.
  - 3. The purge tank shall consist of a cooling coil, filter-drier, water separation tube, sight glass, drain, and air discharge port. Air and water are separated from the refrigerant vapor and accumulated in the purge tank.
  - 4. The pumpout system shall consist of a small compressor and a restriction device located at the pumpout compressor suction connection.
  - 5. The purge unit shall be connected to a 100% reclaim device.
- C. Vacuum Prevention System (Negative pressure chillers only): Chiller manufacturer shall supply and install a vacuum prevention system for each chiller. The system shall constantly maintain 0.05 psig inside the vessel during non-operational periods. The system shall consist of a precision pressure controller, two silicon blanket heaters, a pressure transducer, and solid-state safety circuit.
- D. Refrigerant Detection Device (negative pressure chillers only): Chiller manufacturer shall supply and install a refrigerant detection device and alarm capable of monitoring refrigerant at a level of 10 ppm. Due to the critical nature of this device and possible owner liability, the chiller manufacturer shall guarantee and maintain the detection monitor for five years after owner acceptance of the system.
- E. Waffle type vibration pads for field mounting under unit feet.

## **PART 3 — EXECUTION**

### 3.1 INSTALLATION

- A. Install per manufacturer's requirements, shop drawings, and Contract Documents.
- B. Adjust chiller alignment on foundations, or subbases as called for on drawings.
- C. Arrange piping to allow for dismantling to permit head removal and tube cleaning.
- D. Furnish and install necessary auxiliary water piping for oil cooler.
- E. Coordinate electrical installation with electrical contractor.
- F. Coordinate controls with control contractor.
- G. Provide all materiel required for a fully operational and functional chiller.

### 3.2 START-UP

- A. Units shall be factory charged with the proper refrigerant and oil.
- B. Factory Start-Up Services: The manufacturer shall provide factory authorized supervision for as long a time as is necessary to ensure proper operation of the unit, but in no case for less than two full working days. During the period of start-up, the start-up technician shall instruct the owner's representative in proper care and operation of the unit.

# SECTION 15XXX

## CENTRIFUGAL CHILLERS

### COUNTERFLOW, DUAL COMPRESSORS

#### PART 1 — GENERAL

##### 1.1 SUMMARY

Section includes design, performance criteria, refrigerants, controls, and installation requirements for water-cooled centrifugal chillers.

##### 1.02 REFERENCES

Comply with the following codes and standards

ARI 550/590	NEC
ANSI/ASHRAE 15	OSHA as adopted by the State
ASME Section VIII	

##### 1.3 SUBMITTALS

Submittals shall include the following:

- A. Dimensioned plan and elevation view Drawings, including motor starter cabinet, required clearances, and location of all field piping and electrical connections.
- B. Summaries of all auxiliary utility requirements such as: electricity, water, air, etc. Summary shall indicate quality and quantity of each required utility.
- E. Diagram of control system indicating points for field interface and field connection. Diagram shall fully depict field and factory wiring.
- F. Manufacturer's certified performance data at full load plus IPLV or NPLV.
- E Installation and Operating Manuals.

##### 1.4 QUALITY ASSURANCE

- A. Qualifications: Equipment manufacturer must specialize in the manufacture of the products specified and have five years experience with the equipment and refrigerant offered.
- B. Regulatory Requirements: Comply with the codes and standards in Section 1.2.
- C. Chiller manufacturer plant shall be ISO Certified.

##### 1.5 DELIVERY AND HANDLING

- A. Chillers shall be delivered to the job site completely assembled and charged with refrigerant and oil.
- B. Comply with the manufacturer's instructions for rigging and transporting units. Leave protective covers in place until installation.

##### 1.6 WARRANTY

The refrigeration equipment manufacturer's warranty shall be for a period of (one) -- **Or** -- (two) -- **Or**-- (five) years from date of equipment start or 18 months from shipment whichever occurs first. The warranty shall include parts and labor costs for the repair or replacement of defects in material or workmanship. The refrigerant charge shall be warranted against contamination from a motor burnout for five years.

##### 1.7 MAINTENANCE

Maintenance of the chillers shall be the responsibility of the owner with the following exceptions:

- A. The manufacturer shall provide the first year scheduled oil and filter change if required.
- B. The manufacturer shall provide first year purge unit maintenance if required.

#### PART 2 — PRODUCTS

##### 2.1 ACCEPTABLE MANUFACTURERS

- A. McQuay International
- B. (Approved Equal)

## 2.2 UNIT DESCRIPTION

Provide and install as shown on the plans a factory assembled, charged water-cooled packaged chiller. Each unit shall be complete with two single-stage hermetic centrifugal compressors each having independent lubrication and control systems. Each compressor shall have a dedicated circuit in the evaporator and condenser, and its own refrigerant control device. The chiller unit shall be capable of running on one compressor with the other compressor or any of its auxiliaries inoperable or removed.

Each chiller shall be factory run-tested on an AHRI certified test stand with water at job conditions (excluding glycol applications). Operating controls shall be adjusted and checked. The refrigerant charge shall be adjusted for optimum operation and recorded on the unit nameplate. Units operating with 50-Hz power shall be tested with a 50-Hz power supply. Any deviation in performance or operation shall be remedied prior to shipment and the unit retested if necessary to confirm repairs or adjustments.

## 2.3 DESIGN REQUIREMENTS

- A. General: Provide a complete water-cooled dual centrifugal water chiller as specified herein. Machine shall be provided according to standards, Section 1.2. In general, the unit shall consist of two compressors, two circuited refrigerant condenser and evaporator, two lubrication systems, and two control systems. The vessels shall be single pass with a counterflow water arrangement.  
Note: Chillers shall be charged with a refrigerant such as HFC-134a, not subject to the Montreal Protocol and the U. S. Clean Air Act.
- B. Performance: Refer to schedule on the drawings. The chiller shall be capable of stable operation to five percent of full load with standard ARI entering condensing water relief without hot gas bypass.
- C. Acoustics: Sound pressure for the unit shall not exceed the following specified levels. Provide the necessary acoustic treatment to chiller as required. Sound data shall be measured according to ARI Standard 575-87 and shall be in dB. Data shall be the highest levels recorded at all load points. Test shall be in accordance with ARI Standard 575.

Octave Band	063	125	250	500	1000	2000	4000	8000	dba
	_____	_____	_____	_____	_____	_____	_____	_____	

## 2.4 CHILLER COMPONENTS

- A. Compressors:
1. The chiller shall have two single-stage hermetic centrifugal compressors. Casing design shall ensure major wearing parts, main and thrust bearings are accessible for maintenance and replacement.
  2. The impeller shall be statically and dynamically balanced. The compressor shall be vibration tested and not exceed 0.14 IPS.
  3. Movable inlet guide vanes actuated by an internal oil pressure driven piston shall accomplish unloading. Compressors using an unloading system that requires penetrations of the compressor housing or linkages, or both, that must be lubricated and adjusted are acceptable provided the manufacturer provides a five-year inspection agreement consisting of semi-annual inspection, lubrication, and annual change out of compressor seals. A statement of inclusion must accompany any quotations.
  4. If compressors are not equipped with guide vanes for each stage and movable discharge diffusers, then furnish hot gas bypass and select chillers at 5% lower kW/ton than specified to compensate for bypass inefficiency at low loads.
  5. For air-cooled motors the chiller manufacturer shall be responsible for providing the cooling of the refrigeration machinery room. The sensible cooling load shall be based on the total heat rejection to the atmosphere from tow refrigeration units.
  6. For open motor unit, an oil reservoir shall collect any oil and refrigerant that leaks past the seal. A float device shall be provided to open when the reservoir is full, directing the refrigerant/oil mixture back into the compressor housing. Manufacturer shall warrant the shaft seal, reservoir, and float valve system against leakage of oil and refrigerant to the outside of the refrigerating unit for a period of 5 years from the initial start-up including parts and labor to replace a defective seal and any refrigerant required to trim the charge original specifications

- D. Lubrication System: Each compressor shall have an independent lubrication system to provide lubrication to all parts requiring lubrication. Provide a heater in the lubricant sump to maintain lubricant at sufficient temperature to minimize affinity of refrigerant, and a thermostatically controlled water-cooled oil cooler. Coolers located inside the evaporator or condenser are not acceptable due to inaccessibility. A positive displacement submerged lubricant pump shall be powered through the unit control transformer.
- E. Refrigerant Evaporator and Condenser:
1. Evaporator and condenser shall be of the shell-and-tube type, designed, constructed, tested and stamped according to the requirements of the ASME Code, Section VIII. Regardless of the operating pressure, the refrigerant side of each vessel will bear the ASME stamp indicating compliance with the code and indicating a test pressure of 1.3 times the working pressure but not less than 100 psig. Provide intermediate tube supports at a maximum of 18 inch spacing.
  2. Each vessel shall have two refrigerant circuits, separated by an intermediate tube sheet.
  3. Tubes shall be enhanced for maximum heat transfer, rolled into steel end and intermediate tube sheets and sealed with Locktite or equal sealer. The tubes shall be individually replaceable.
  4. Provide sufficient isolation valves and condenser volume to hold full refrigerant charge in either condenser circuit during servicing or provide a separate pumpout system and storage tank sufficient to hold the charge of the largest circuit being furnished.
  5. The water sides shall be designed for a minimum of 150 psig or as specified elsewhere. Vents and drains shall be provided.
  6. Chilled water minimum refrigerant temperature shall be 33°F.
  7. An electronic or thermal refrigerant expansion valve shall control refrigerant flow to the evaporator. Fixed orifice devices or float controls with hot gas bypass are not acceptable because of inefficient control at low load conditions. The liquid line shall have a moisture indicating sight glass.
  8. The evaporator and condenser shall be separate shells. A single shell containing both vessel functions is not acceptable because of the possibility of internal leaks.
  9. Interstage economizers shall be used between each compressor stage on multi-stage compressors for increased efficiency.
  10. Reseating type spring loaded pressure relief valves according to ASHRAE-15 safety code shall be furnished. The evaporator shall be provided with single or multiple valves. The condenser shall be provided with dual relief valves equipped with a transfer valve so one valve can be removed for testing or replacement without loss of refrigerant or removal of refrigerant from the vessel. Rupture disks are not acceptable.
  11. The evaporator, suction line, and any other component or part of a component subject to condensing moisture shall be insulated with UL recognized 3/4 inch closed cell insulation. All joints and seams shall be carefully sealed to form a vapor barrier.
  12. Provide a factory-installed, thermal dispersion, water flow switches on each vessel to prevent unit operation with no flow.
- D. Prime Mover: Squirrel cage induction motor of the hermetic type of sufficient size to efficiently fulfill compressor horsepower requirements. Motor shall be liquid refrigerant cooled with internal thermal overload protection devices embedded in the winding of each phase. Motor shall be compatible with the starting method specified hereinafter. If the Contractor chooses to provided an open drive motor or compressor, verify in the submittal that the scheduled chiller room ventilation system will accommodate the additional heat and maintain the equipment room at design indoor temperature based on 95°F outdoor ambient ventilation air available.
- If additional cooling is required, manufacturer shall be responsible for the installation, wiring and controls of a cooling system. Chiller selection shall compensate for tons and efficiency loss to make certain the owner is not penalized.
- E. Motor Starters:
- The main motor starters are to be furnished by the chiller manufacturer and shipped loose for floor mounting and field wiring to the chiller package. They shall be free-standing with NEMA-1 enclosure designed for top entry and bottom exit and with front access. The starters must comply with the codes and standards in Section 1.2 as required.

1. **Low Voltage (200 through 600 volts)** controllers are to be continuous duty AC magnetic type constructed according to NEMA standards for Industrial Controls and Systems (ICS) and capable of carrying the specified current on a continuous basis. The starters shall be:

Wye-Delta Closed Transition - The starter shall be equipped with properly sized resistors to provide a smooth transition. The resistors shall be protected with a transition resistor protector, tripping in a maximum of two seconds, locking out the starter, and shall be manually reset. A clearly marked transition timer shall be adjustable from 0 to 30 seconds or a current sensing device shall initiate transition when the starting current drops to 90% of the unit RLA.

-- OR --

Solid-State Reduced Voltage - Starter shall be furnished with silicon controlled rectifiers (SCR) connected for starting and include a bypass contactor. When operating speed is reached, the bypass contactor shall be energized removing the SCRs from the circuit during normal running.

All Low Voltage starters shall:

- a) Be coordinated with the chiller package(s) making certain all terminals are properly marked according to the chiller manufacturer's wiring diagrams.
- b) The starters shall be equipped with a motor control relay (MCR). The relay shall interconnect the starter with the unit control panel and directly operate the main motor contactor. The MCRs shall constitute the only means of energizing the motor starter.
- c) The main contactors shall have a normally-open auxiliary contact rated at 125VA pilot duty at 115 VAC. An additional set of normally open contacts shall be provided on the MCR.
- d) There shall be electronic overloads in each phase, which will permit continuous operation at 107% of the rated load amps of each motor. The overloads shall have a must-trip setting at 125% of the RLA. Overloads shall be manual reset and shall de-energize the main contactors when the overcurrent occurs. The overloads shall be adjustable, have manual reset, be ambient compensated, and set for Class 10 operation.
- e) Each starter shall have a current transformer and adjustable voltage dropping resistor(s) to supply a 5.0 VAC signal at full load to the unit control panels.
- f) Each starter shall be equipped with a line to 115 VAC control transformer, fused in both the primary and secondary, to supply power to the control panels, oil heaters and oil pumps.
- g) Each starter shall include the following protective devices:
  - Phase failure and reversal protection
  - Under/over voltage protection
  - Stall protection

-OR-

2. **Variable Frequency Drive**

- a) The chiller shall be equipped with a Variable Frequency Drive (VFD) to automatically regulate each compressor speed in response to cooling load and compressor pressure lift. The chiller control shall coordinate compressor speed and guide vane position to optimize chiller efficiency.
- b) A digital regulator shall provide V/Hz control.
- c) The VFD shall have 110% continuous overload of continuous amp rating with no time limit, PWM (pulse width modulated) output, IGBT (insulated gate bipolar transistors) power technology and full power rating at 2kHz, DC bus inductor (choke), and wireless construction.
- d) All heat producing devices shall be contained in a single heatsink with single inlet and out connections for the connection of chilled water. When factory mounted on the chiller package, the water connections shall be piped and leak tested at the factory.

-OR-

3. **Medium Voltage (601 through 7200 volts)**. The starters shall be:

- a) Solid-State Reduced Voltage. Starter shall be furnished with silicon controlled rectifiers (SCR) connected for starting and include a bypass contactor. When operating speed is reached, the bypass contactor shall be energized removing the SCRs from the circuit during normal running.
  - (1) The starter shall be coordinated with the chiller package(s) making certain all terminals are properly marked according to the chiller manufacturer's wiring diagrams.

- (2) The starters shall be equipped with a redundant motor control relay (MCR), which interconnects the starter with the unit control panel and directly operates the main motor contactors. The MCRs shall constitute the only means of energizing the motor starter.
  - (3) The main contactors shall have a normally open auxiliary contact rated at 125VA pilot duty at 115 VAC. An additional set of normally open contacts shall be provided on the MCR.
  - (4) There shall be electronic overloads in each phase, which will permit continuous operation at 107% of the rated load amps of each motor. The overloads shall have a must-trip setting at 125% of the RLA. Overloads shall be manual reset and shall de-energize the main contactors when the overcurrent occurs. The overloads shall be adjustable, have manual reset, be ambient compensated, and set for Class 10 operation
  - (5) Each starter shall have a current transformer and adjustable voltage dropping resistor(s) to supply a 5.0 VAC signal at full load to the unit control panels.
  - (6) Each starter shall be equipped with a line-to-115 VAC control transformer, fused in both the primary and secondary, to supply power to the control panels, oil heaters and oil pumps.
  - (7) Each starter shall include the following:
    - (i) Phase failure and reversal protection
    - (ii) Under/over voltage protection
    - (iii) Load break disconnect switch on solid state or across-the-line starters  
Isolating safety switch on autotransformer or primary reactor starters
    - (iv) Current limiting power fuses
- OR--**
- b) **Across-the-Line** type with primary contactor allowing locked rotor amps to reach the motor when energized including items a through g above.
- OR--**
- c) **Autotransformer** type factory wired to the 65% tap with drawout magnetic, three-pole, vacuum break shorting contactor, drawout magnetic, two-pole, vacuum break starting contactor, and open delta starting auto-transformer factory set at 65% including items a through g above.
- OR--**
- d) **Primary Reactor** type with drawout magnetic, three-pole, vacuum break shorting assembly, and three-phase starting reactor, factory set at the 65% tap including items a through g above.

All medium and high voltage starters shall have the following components:

#### **Main Control Relays**

A motor control relay shall be provided to interlock the starter with the chiller. The two relay shall constitute the only means of energizing the motor starter. No other devices (manual or automatic) with the capability of energizing the starter can be used. The starter is to be controlled by the unit microprocessor.

#### **Motor Protection and Overloads**

The starter shall include overload protection functions. These controls include:

- Solid state overload (overcurrent) protection
- Phase unbalance protection
- Phase reversal and phase loss protection.
- Adjustable overload to closely match motor performance
- Three current transformers to measure motor current and a fourth current transformer for input to the chiller microprocessor.

#### **Undervoltage (UV) Relay**

The undervoltage relay is an adjustable three-phase protection system that is activated when the voltage falls below a predetermined safe value and is factory set at 85% of nominal.

#### **Control Voltage Transformer**

The starter is provided with a 3KVA control transformer with both secondary and primary fuses to supply control power to the chiller.

### Additional Standard Components

- Mechanical type solderless connectors to handle wire sizes indicated by the NEC.
- Three vertically mounted current limiting power fuse blocks (fuses included)
- Magnetic three-pole, vacuum break contactor
- Single phase control circuit transformer
- Vertically mounted control circuit primary current limiting fuses
- Current transformers
- Load terminals
- Control circuit terminal blocks and secondary fuses
- Phase failure and reversal relay

### G. CHILLER CONTROLLER

Chiller control shall be done through unit controller (microprocessor) and a controller for each compressor, all of which shall have a 4-by-20-character display to view system parameters, denote alarms and input setpoints.

In conjunction with these controllers, the primary operator interface shall be a state-of-the-art super VGA color touch screen monitor and USB port.

The control system shall have inherent trend logging capabilities, which are transferable to other PC management systems such as an Excel spread sheet via a USB port. Active trend logging data shall be available for viewing in 20 minute, 2 hour or 8 hour intervals. A full 24 hours of history shall be downloadable via the USB port. The following trended parameters shall be displayed:

- Entering and leaving chilled water temps
- Entering and leaving condenser water temps
- Evaporator saturated refrigerant pressure
- Condenser saturated refrigerant pressure
- Net oil pressure for each compressor
- % rated load amps for entire unit

In addition to the trended items above, other real-time operating parameters shall also be shown on the touch screen. These items can be displayed in two ways: by chiller graphic showing each component or from a color-coded, bar chart format. At a minimum, the following critical areas must be monitored:

- Oil sump temperature per compressor
- Oil feed line temperature per compressor
- Evaporator saturated refrigerant temperature for unit
- Suction temperature for unit
- Condenser saturated refrigerant temperature for unit
- Discharge temperature for unit
- Liquid line temperature for unit

The unit operating and maintenance instructions shall be viewable on the touch screen and downloadable via the onboard USB port.

Complete fault history shall be displayed using an easy to decipher, color coded set of messages that are date and time stamped. The last 20 faults shall be downloadable from the USB port.

Automatic corrective action to reduce unnecessary cycling shall be accomplished through pre-emptive control of low evaporator or high discharge pressure conditions to keep the unit operating through ancillary transient conditions.

System specific, chiller plant architecture software shall be employed to display the chiller, piping, pumps and cooling tower. Chiller plant optimization software for up to 4 chillers shall also be included to provide automatic control of: evaporator and condenser pumps (primary and standby), up to 4 stages of cooling tower fans and a cooling tower modulating bypass valve or cooling tower variable frequency drives. There shall be five possible tower control strategies:

- Tower fan staging only – up to 4 stages controlled by either the entering condenser water temperature or lift differential temperature between the condenser and evaporator saturated temperatures.
- Tower fan staging plus low limit - controlled as in # 1 plus tower bypass valve set at a minimum entering condenser water temperature.
- Tower staging with staged bypass control – similar to # 2 with additional control of the bypass valve between fan staging to smooth control and minimize fan staging.
- VFD staging only – in this mode, a variable speed drive controls the first fan with up to 3 more fans to be staged on and off and there is no bypass valve.
- VFD and Valve Staging – same as # 4 plus bypass valve control.

Factory mounted DDC controllers shall support operation on a BACnet®, Modbus® or LONWORKS® network via one of the data link / physical layers listed below as specified by the successful Building Automation System supplier.

BACnet MS/TP master (Clause 9)

BACnet IP, (Annex J)

BACnet ISO 8802-3, (Ethernet)

LONWORKS FTT-10A

The information communicated between the building automation system and the factory mounted unit controllers shall include the reading and writing of data to allow unit monitoring, control and alarm notification as specified in the unit sequence of operation and the points list.

## 2.5. MISCELLANEOUS ITEMS

- A. Pumpout System: The unit shall be equipped with a pumpout system complete with a transfer pump, condensing unit, and storage vessel constructed according to ASME Code for Unfired Pressure Vessels and shall bear the National Boards stamp. If the design of the unit allows the charge to be transferred to and isolated in the main condenser, then a pumpout system is not required. Transfer of refrigerant charge shall be accomplished by either main compressor operation, migration, or gravity flow. Isolation shall be accomplished with valves located at the inlet and exit of the condenser. The main condenser shall be sized to contain the refrigerant charge at 90°F according to ANSI-ASHRAE 15.A.
- B. Purge System (negative pressure chillers only):
1. The chiller manufacturer shall provide a separate high efficiency purge system that operates independently of the unit and can be operated while the unit is off. The system shall consist of an air-cooled condensing unit, purge condensing tank, pumpout compressor and control system.
  2. A dedicated condensing unit shall be provided with the purge system to provide a cooling source whether or not the chiller is running. The condensing unit shall provide a low purge coil temperature to result in a maximum loss of 0.1 pounds of refrigerant per pound of purged air.
  3. The purge tank shall consist of a cooling coil, filter-drier, water separation tube, sight glass, drain, and air discharge port. Air and water are separated from the refrigerant vapor and accumulated in the purge tank.
  4. The pumpout system shall consist of a small compressor and a restriction device located at the pumpout compressor suction connection.
- C. Vacuum Prevention System (Negative pressure chillers only): Chiller manufacturer shall supply and install a vacuum prevention system for each chiller. The system shall constantly maintain 0.05 psig inside the vessel during non-operational periods. The system shall consist of a precision pressure controller, two silicon blanket heaters, a pressure transducer, and solid-state safety circuit.
- D. Refrigerant Detection Device (negative pressure chillers only): Chiller manufacturer shall supply and install a refrigerant detection device and alarm capable of monitoring refrigerant at a level of 10 ppm. Due to the critical nature of this device and possible owner liability, the chiller manufacturer shall guarantee and maintain the detection monitor for five years after owner acceptance of the system.
- E. Waffle type vibration pads for field mounting under unit feet.



## **PART 3 — EXECUTION**

### **3.1 INSTALLATION**

- A. Install per manufacturer's requirements, shop drawings, and Contract Documents.
- B. Adjust chiller alignment on foundations, or subbases as called for on drawings.
- C. Arrange piping to allow for dismantling to permit head removal and tube cleaning.
- D. Furnish and install necessary auxiliary water piping for oil cooler.
- E. Coordinate electrical installation with electrical contractor.
- F. Coordinate controls with control contractor.
- G. Provide all materiel required for a fully operational and functional chiller.

### **3.2 START-UP**

- A. Units shall be factory charged with the proper refrigerant and lubricant.
- B. Factory Start-Up Services: Provide for as long a time as is necessary to ensure proper operation of the unit, but in no case for less than two full working days. During the period of start-up, The Start-up Technician shall instruct the Owner's representative in proper care and operation of the unit.





All McQuay equipment is sold pursuant to McQuay's Standard Terms and Conditions of Sale and Limited Product Warranty. Consult your local McQuay Representative for warranty details. Refer to form 933-430285Y. To find your local representative, [www.mcquay.com](http://www.mcquay.com).

This document contains the most current product information as of this printing. For the most up-to-date product information, please go to [www.mcquay.com](http://www.mcquay.com).

