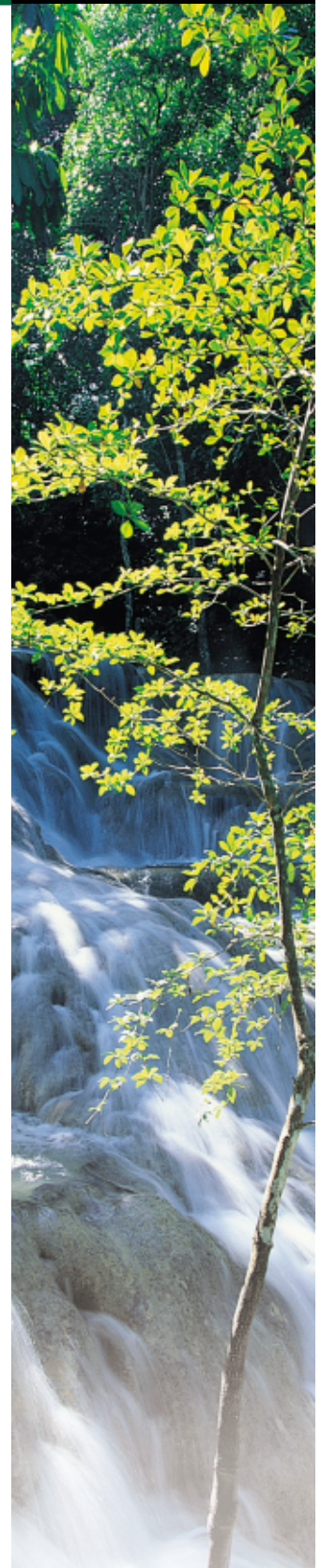


# McQuay Enfinity™ Horizontal & Vertical Water Source Heat Pumps

Ceiling Concealed, Vertical Floor  
Standard and Extended Range Unit Sizes 1/2 to 5 Tons



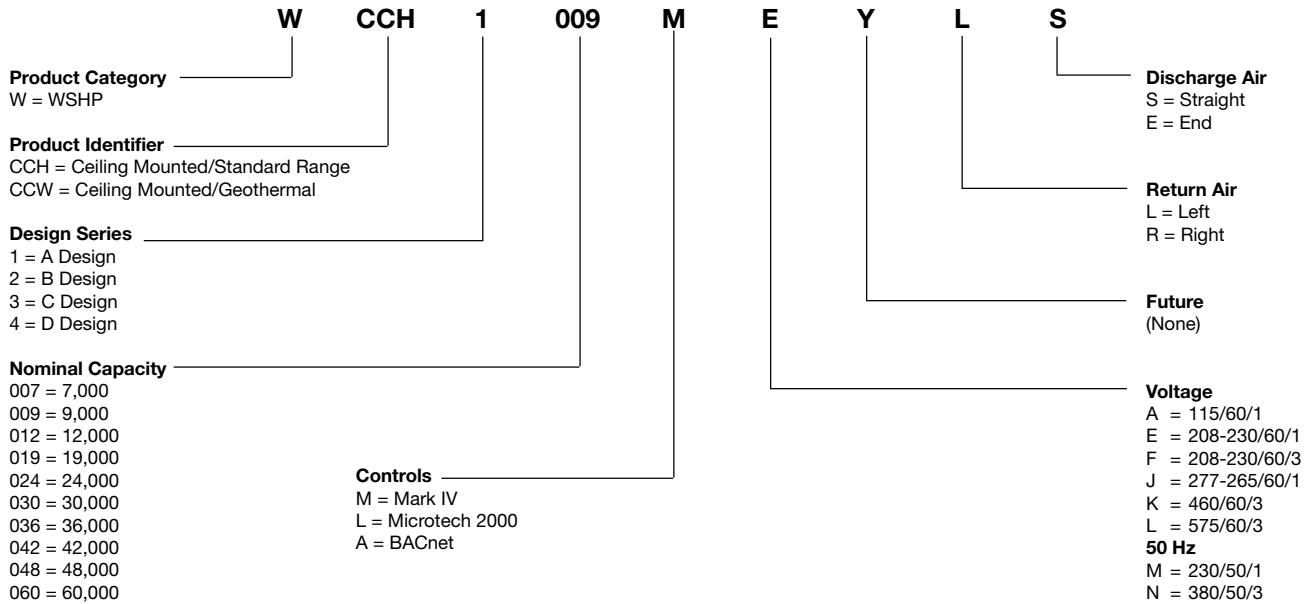
# Table of Contents

<b>Enfinity Product Model Nomenclature</b> .....	<b>3</b>	Horizontal (Right Hand) Sizes 007, 009, 012 .....	55
<b>Design Features (Horizontal Ceiling Unit)</b> .....	<b>5</b>	Horizontal (Left Hand) Sizes 019, 024 .....	56
<b>Horizontal Unit Features &amp; Benefits</b> .....	<b>6-8</b>	Horizontal (Right Hand) Sizes 019, 024 .....	57
<b>Design Features (Vertical Floor Unit)</b> .....	<b>9</b>	Horizontal (Left Hand) Sizes 030, 036 .....	58
<b>Vertical Unit Features &amp; Benefits</b> .....	<b>10-11</b>	Horizontal (Right Hand) Sizes 030, 036 .....	59
<b>Enfinity Product Features</b> .....	<b>12-13</b>	Horizontal (Left Hand) Sizes 042, 048, 060 .....	60
<b>Control Options - 3 Unique Control Systems</b> .....	<b>14-19</b>	Horizontal (Right Hand) Sizes 042, 048, 060 .....	61
Mark IV .....	15	Filter Rack, Return Air Duct Collar .....	62
Microtech™ 2000 .....	16	<b>Enfinity Vertical ISO Performance Data</b> .....	<b>63-65</b>
BACnet® .....	17-18	ISO Performance Data - Water Loop .....	63
Loop Water Controller .....	19	ISO Performance Data - Ground Loop .....	64
<b>Applications - Systems</b> .....	<b>20-22</b>	ISO Performance - Ground Source .....	65
Heating and Cooling Refrigeration Cycle .....	20	<b>Vertical Unit Capacity Data</b> .....	<b>66-85</b>
Boiler Tower Application .....	21	Cooling - Size 007 .....	66
Open Loop Well Water Application .....	21	Heating - Size 007 .....	67
Closed Loop Geothermal Application .....	22	Cooling - Size 009 .....	68
Vertical Loop .....	22	Heating - Size 009 .....	69
Horizontal Loop .....	22	Cooling - Size 012 .....	70
Surface Water (Lake) .....	22	Heating - Size 012 .....	71
<b>Applications Considerations</b> .....	<b>23-25</b>	Cooling - Size 019 .....	72
Typical Horizontal Installation .....	23	Heating - Size 019 .....	73
Unit Location .....	23	Cooling - Size 024 .....	74
Piping .....	23	Heating - Size 024 .....	75
Condensate Drain Piping .....	23	Cooling - Size 030 .....	76
Ductwork & Sound Considerations .....	24	Heating - Size 030 .....	77
Typical Vertical Installation .....	25	Cooling - Size 036 .....	78
<b>Applications - Unit Selection</b> .....	<b>26</b>	Heating - Size 036 .....	79
<b>Enfinity Horizontal ISO Performance Data</b> .....	<b>27-39</b>	Cooling - Size 042 .....	80
ISO Performance Data - Water Loop .....	27	Heating - Size 042 .....	81
ISO Performance Data - Ground Loop .....	28	Cooling - Size 048 .....	82
ISO Performance - Ground Source .....	29	Heating - Size 048 .....	83
<b>Horizontal Unit Capacity Data</b> .....	<b>30-49</b>	Cooling - Size 060 .....	84
Cooling - Size 007 .....	30	Heating - Size 060 .....	85
Heating - Size 007 .....	31	<b>Vertical Unit Performance Data - Operating Limits</b> .....	<b>86</b>
Cooling - Size 009 .....	32	<b>Vertical Unit Correction Factors</b> .....	<b>87</b>
Heating - Size 009 .....	33	<b>Vertical Unit Electrical Data</b> .....	<b>88</b>
Cooling - Size 012 .....	34	<b>Vertical General Data</b> .....	<b>89</b>
Heating - Size 012 .....	35	Physical Data .....	89
Cooling - Size 019 .....	36	Fan Performance .....	89
Heating - Size 019 .....	37	<b>Dimensional Data</b> .....	<b>90-94</b>
Cooling - Size 024 .....	38	Vertical (Left & Right Hand) Sizes 007, 009, 012 .....	90
Heating - Size 024 .....	39	Vertical (Left & Right Hand) Sizes 019, 024 .....	91
Cooling - Size 030 .....	40	Vertical (Left & Right Hand) Sizes 030, 036 .....	92
Heating - Size 030 .....	41	Vertical (Left & Right Hand) Sizes 042, 048 .....	93
Cooling - Size 036 .....	42	Vertical (Left & Right Hand) Size 060 .....	94
Heating - Size 036 .....	43	<b>Enfinity Wiring Diagrams</b> .....	<b>95-97</b>
Cooling - Size 042 .....	44	Mark IV/AC - 007 thru 060 .....	95
Heating - Size 042 .....	45	Microtech 2000 - 007 thru 060 .....	96
Cooling - Size 048 .....	46	BACnet - 007 thru 060 .....	97
Heating - Size 048 .....	47	<b>Enfinity Field Installed Accessories</b> .....	<b>98-100</b>
Cooling - Size 060 .....	48	Thermostats .....	98-99
Heating - Size 060 .....	49	Supply & Return Hoses .....	99
<b>Horizontal Unit Performance Data - Operating Limits</b> .....	<b>50</b>	Condensate Hose Kit .....	99
<b>Horizontal Unit Correction Factors</b> .....	<b>51</b>	Combination Balancing Shut-off Valves .....	100
<b>Horizontal Unit Electrical Data</b> .....	<b>52</b>	Motorized Valve .....	100
<b>Horizontal General Data</b> .....	<b>53</b>	Two inch Filter Rack .....	100
Physical Data .....	53	Boilerless System Kit .....	100
Fan Performance .....	53	Field Installed Controls .....	100
<b>Dimensional Data</b> .....	<b>54-61</b>	<b>Enfinity Guide Specifications</b> .....	<b>101-104</b>
Horizontal (Left Hand) Sizes 007, 009, 012 .....	54		

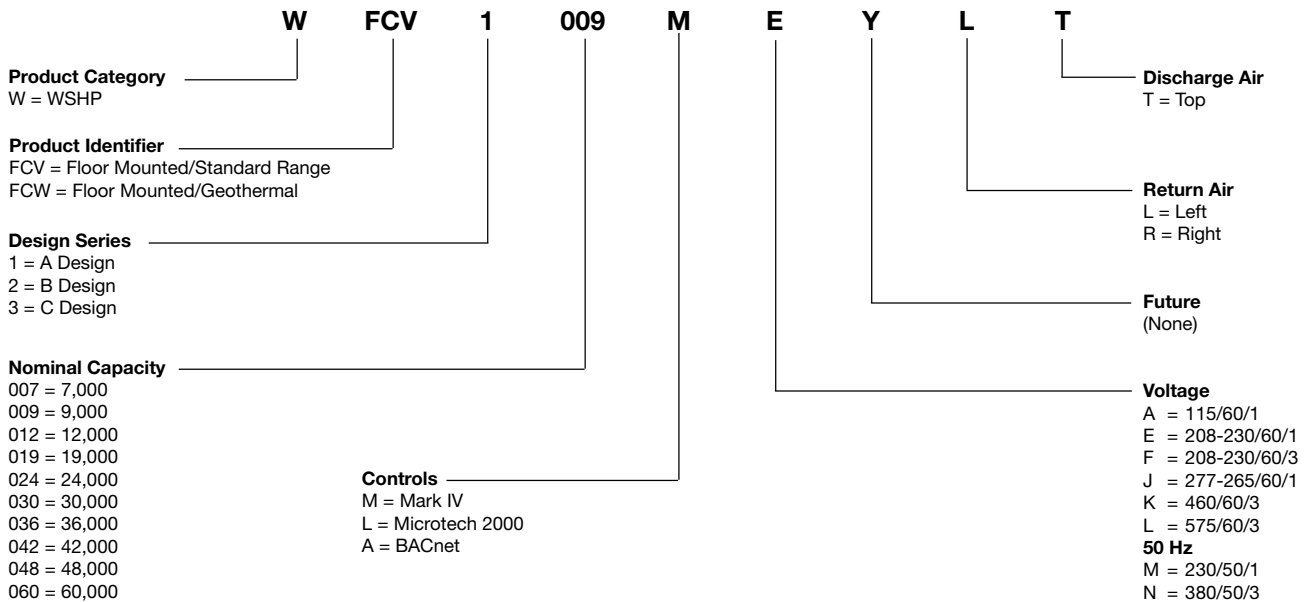
# Enfinity Model Nomenclature

## Horizontal Ceiling Unit

**NOTE:** For illustration purposes only. Not all options available with all models. Please consult McQuay Sales Representative for specific availability.



## Vertical Floor Unit



# Introduction

## McQuay Enfinity™ Water Source Heat Pumps

More than 30 years ago, McQuay designed the first complete line of water source heat pumps for high efficiency, individually-zoned comfort control in offices, schools, assisted living facilities, manufacturing facilities and other commercial buildings. Our reputation for outstanding reliability and quiet operation has been reinforced in thousands of successful installations.

McQuay Enfinity™ water source heat pumps incorporate the best of our past and the best of what's new. Using feedback from building owners, consulting engineers, contractors and service engineers, we designed Enfinity products to give you maximum flexibility to design, install, operate and maintain the ideal water source heat pump system for your building project. And we incorporated non-ozone depleting R-410A refrigerant, which—along with high Energy Efficiency Ratios (EER's)—helps preserve our environment and precious energy resources.



McQuay Air Conditioning plant with over 450,000 square feet of manufacturing space - located in Auburn, New York

## With McQuay Enfinity Water Source Heat Pumps, you benefit from:

- Easy, low cost design and installation.
- Standard or extended range/geothermal application flexibility.
- High efficiency, low operating costs.
- Superior indoor air quality.
- Easy, low-cost maintenance and service.
- Broadest selection of non-CFC, R-410A refrigerant.
- Quiet, reliable operation.

## Horizontal (Ceiling) Water Source Heat Pumps – 1/2 to 5 Tons

*Model CCH (Standard Range: 55°F to 110°F)*  
*Model CCW (Extended Range/Geothermal: 25°F to 110°F)*



## Vertical (Floor) Water Source Heat Pumps 1/2 to 5 Tons

*Model FCV (Standard Range: 55°F to 110°F)*  
*Model FCW (Extended Range/Geothermal: 25°F to 110°F)*



LONMARK<sup>3E3</sup>

MicroTech 2000 unit controllers are LONMARK certified



“McQuay” is a registered trademark of McQuay International.  
©McQuay International 2003. All rights reserved throughout the world.

The information in this manual supersedes and replaces previous catalogues with regards to McQuay Water Source Heat Pump products. Illustrations cover the general appearance of McQuay International products at the time of publication and McQuay International reserves the right to make changes in design and construction at anytime without notice.

# Horizontal Ceiling Design Features

## Fan Section

Fan section is separated from the compressor section with an insulated divider panel for maximum sound attenuation. A large removable panel provides easy service access to the blower and motor.

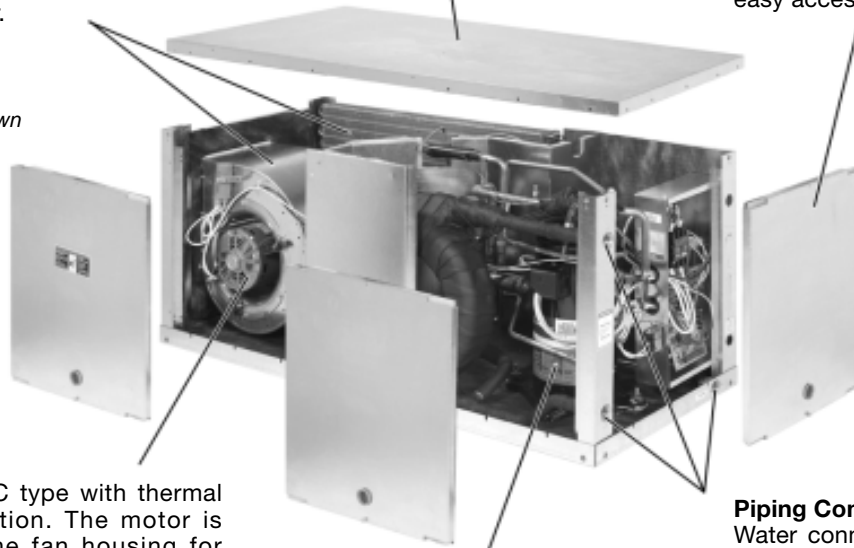
## Cabinet

Durable, heavy gauge galvanized steel cabinet construction.

## Removable Access Panels

Both end and side panels provide easy access to compressor compartment, blower and motor. End panel provides easy access to the unit controls.

*Right Hand Return, End Discharge Shown*



## Blower Motor

Multi-speed, PSC type with thermal overload protection. The motor is isolated from the fan housing for minimum vibration transmission. Removable orifice ring allows easy removal of blower and motor.

## Compressor

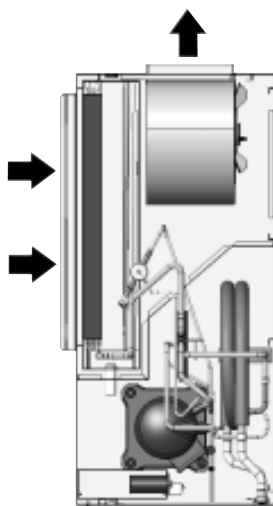
Mounted close to the access panel for maximum serviceability and isolated from the bottom panel with rubber isolators.

## Piping Connections

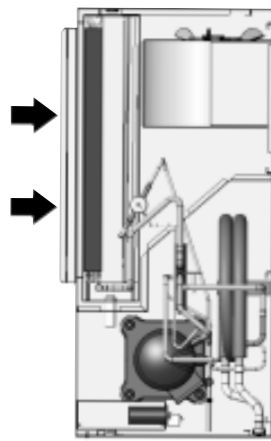
Water connections are FPT water fittings, flush with the outside of the cabinet, allowing easy one-wrench connection of units. The large condensate connection provides for proper condensate removal.

# Flexible Cabinet Configurations

## Cabinet Configurations – Left Hand

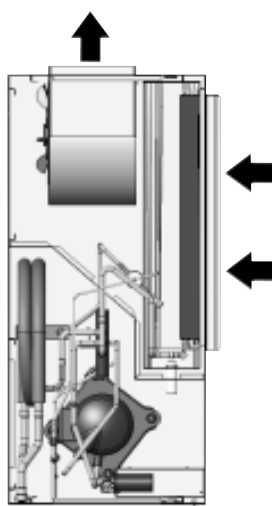


*Figure 6A - Left Hand Return with End Discharge*

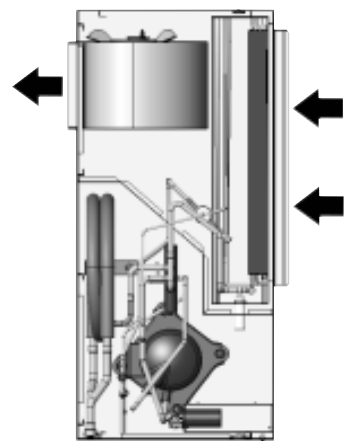


*Figure 6B - Left Hand Return with Straight Discharge*

## Cabinet Configurations – Right Hand



*Figure 6C - Right Hand Return with End Discharge*



*Figure 6D - Right Hand Return with Straight Discharge*

# Horizontal Unit Features and Benefits

Enfinity Horizontal Units Available in Four Cabinet Sizes - 007 thru 060



## Cabinet

McQuay Enfinity horizontal water source heat pumps are available in four cabinet sizes, each with the lowest possible profile to conserve space.

Consistencies in shape, connection locations, parts and assemblies throughout the four cabinets make layout, installation and service simple.

- All water and electrical connections are made from the front of the unit.
- A large, lift-up-and-out panel provides easy access to the control box, refrigeration circuit and compressor.
- A second large panel provides easy service access to the compressor
- A third large panel allows complete service of the blower section while the unit is hanging and without disconnecting the unit from the ductwork.
- Cabinet surfaces are constructed of unpainted, G-60 galvanized steel.
- Panel interiors and the bottom of the unit are covered with 1/2" (12.7 mm) thick, 1 1/2 lb. (681g) density, coated, acoustic type glass fiber insulation.

## Cabinet Configurations

McQuay Enfinity horizontal heat pumps offer four configurations to meet your space requirements (see figures 6A – 6D on page 5). Whether working around obstacles or laying out units down a corridor, the mirror image design of the units lets you configure the system using minimum ductwork and piping. This helps reduce design, material and installation costs.

For maximum flexibility, the fan discharge can exit from the end or side of the unit. This can be configured at the factory or field-converted using interchangeable side and end panels.

## Low Design And Installation Costs

- Four configurations for each unit size (left or right return and straight or end discharge) allow you to specify units to fit space requirements and to design the system using minimum ductwork and piping.
- Four cabinet sizes, each with McQuay's low-profile design, make it easy to meet the space requirements of your new construction or replacement application.
- Flush FPT water fittings allow easy, one-wrench connection of units and help reduce delays caused by shipping damage.
- Flexible control options that include standalone or network operation with the building automation system of your choice using LonMark® or native BACnet® communications.
- Unit hangers are adjustable on 8 points to provide maximum flexibility to install units around obstructions or use existing hangers from units that are being replaced.

## High Energy Efficiency

- High unit EERs result in low operating costs.
- Each unit includes a thermal expansion valve for precise refrigerant flow metering to meet load requirements and increase efficiency at any fluid temperature, including low temperature geothermal applications.
- The coaxial heat exchanger is designed for maximum heat transfer at normal and low water flow rates with minimum pressure drop.
- High efficiency fan motor and low-speed fan operation reduce energy consumption.

## Superior Indoor Air Quality

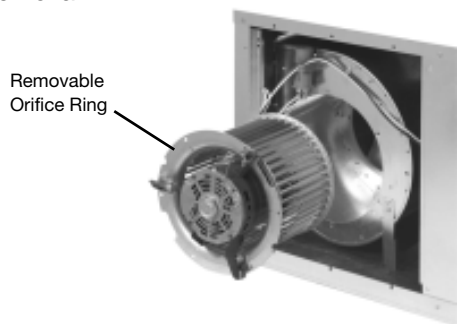
- A standard, corrosion-free plastic drain pan is double-sloped to eliminate standing water and inhibit microbial growth.
- Optional non-fibrous insulation is available for sensitive applications.

# Horizontal Unit Features and Benefits

## Easy, Low-Cost Maintenance

- Easy access to the unit compressor (2-sides), fan and motor (1-side) and controls (end access).
- A removable orifice ring allows the blower and motor to be removed without removing the blower housing or disconnecting the unit from the ductwork.

### *Removable Orifice Ring for Easy Blower and Motor Removal*



## Quiet, Environmentally Friendly Operation

- Large fan wheel allows the fan motor to operate at lower speed for quieter operation.
- Heavy gauge cabinet construction and vibration isolated hanger brackets minimize noise and vibration.
- Three quiet compressor selections (depending on voltage and size variations) including rotary (sizes 007 to 012), reciprocating (sizes 019 to 024) and scroll compressors (sizes 030 to 060).
- R-410A refrigerant (sizes 019 to 060) is classified in ASHRAE standard 31 as lower toxicity, no flame propagation, non-ozone depleting HFC refrigerant.
- R-22 refrigerant (sizes 007 to 012) is classified in ASHRAE standard 31 as lower toxicity, no flame propagation, non-ozone depleting HFC refrigerant.
- Optional mass plates under compressor for noise sensitive option.

### *Removable Panels Provide Easy Access*



## Filter Rack

The filter is supported by factory mounted brackets that allow for face removal. Units come standard with a 1" (25.4 mm) thick throwaway filter mounted in a combination filter rack and return air duct collar, thus eliminating field mounted brackets. The filter can be removed from any of the four sides or from the front.

- Optional 2" filter rack kit for higher filtration efficiency applications.

### *Filter Mounting Brackets*

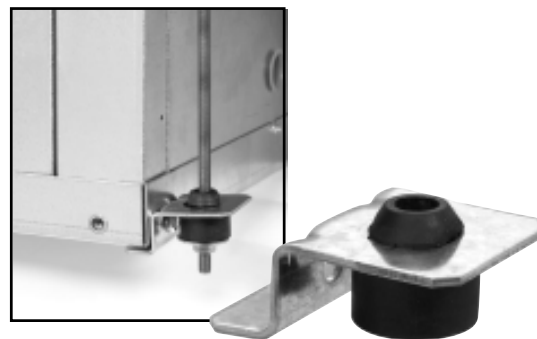


Easy to remove filter from any side

## Hanger Bracket

Each unit is furnished with a mounting kit that includes four heavy metal hanger brackets for hanging the unit from field-supplied hanger rods. Rubber isolators are included for sound and vibration attenuation, as are mounting washers, bolts and lock washers. The hangers are attached to fasteners at each corner of the unit, which are an integral part of the cabinet. Two fasteners are provided at each corner—one on each side—allowing you to optimize the positioning of the unit and the hanger rods.

### *Unit Hangers*



# Horizontal Unit Features and Benefits

## Blower Housing

The blower housing protrudes from the side of the cabinet, allowing adequate material for connection to a flexible duct. For maximum flexibility, the fan discharge can exit from the end or the side of the unit. This can be configured at the factory or can be field-converted before installation, using interchangeable side and end panels.

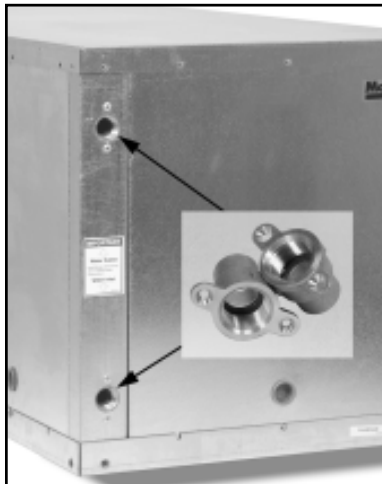
*Fan Housing Protrudes Through the Cabinet for Connection of Flexible Duct*



## Water Connections

The water and condensate connections are FPT fittings, securely mounted flush to the corner post to allow for connection to a flexible hose without the use of a back-up wrench. This helps reduce the time required to connect the unit and helps prevent delays due to shipping damage.

*Flush FPT Water Fittings*



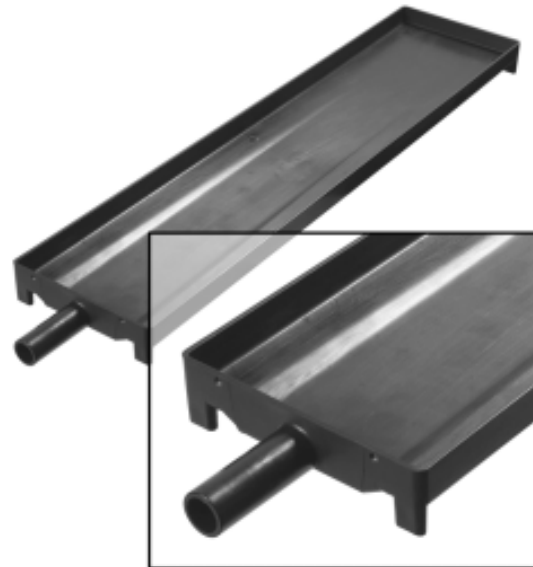
## Electrical

The electrical components are located in the compressor section of the unit. Separate holes are provided on the cabinet to facilitate main power and low voltage control wiring. All wiring connections are made internal to the cabinet to reduce the risk of accidental contact. Each unit is rated to accept time-delay fuses for branch circuit overcurrent protection. Single phase units are also rated for use with HACR circuit breakers.

## Drain Pan

McQuay Enfinity horizontal heat pumps come standard with a corrosion-resistant plastic drain pan to promote good indoor air quality. The pan is double sloped for positive draining to reduce the occurrence of standing water and microbial growth.

*Corrosion-Resistant, Double-Sloped Plastic Drain Pan*





# Vertical Floor Design Features

## Filter Rack

Units come standard with a 1" (25.4 mm) thick throwaway filter mounted in a 4-sided combination filter rack and return air duct collar, thus eliminating field mounted brackets. The filters can be easily removed from any side.

## Blower Motor

Multi-speed, PSC type with thermal overload protection. The motor is isolated from the fan housing for minimum vibration transmission. Removable orifice ring allows easy removal of blower and motor.

## Compact Cabinet

Constructed of unpainted G-60 galvanized steel, with the smallest possible footprint.

## Removable Access Panels

Two front panels provide easy access to blower motor and unit controls. Two rear panels provide easy access to fan housing and compressor section.

## Coaxial Heat Exchanger

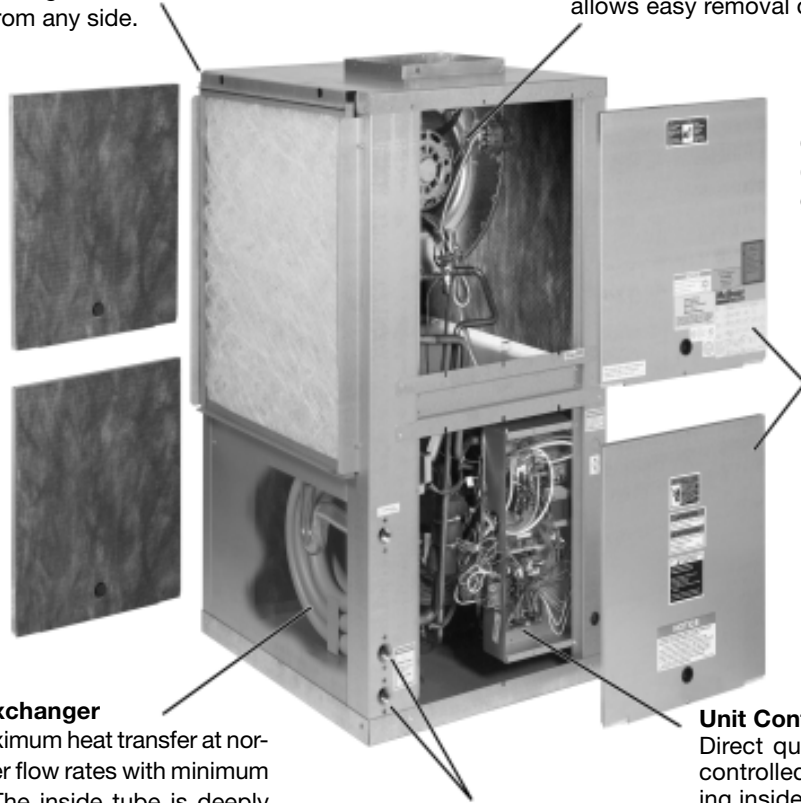
Designed for maximum heat transfer at normal and low water flow rates with minimum pressure drop. The inside tube is deeply fluted to enhance heat transfer and minimize fouling.

## Unit Controls

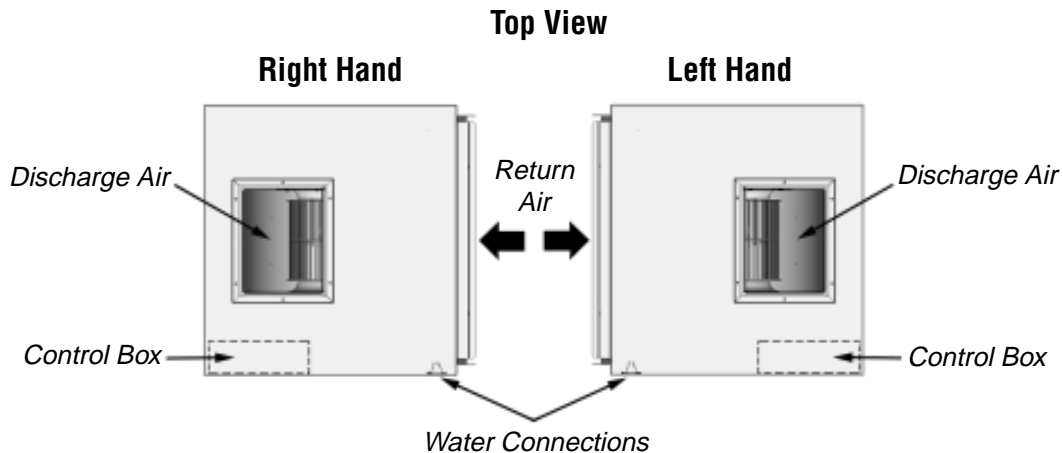
Direct quick-connect wiring to all unit-controlled components for "clean" wiring inside the control box.

## Piping Connections

Water connections are FPT water fittings, flush with the outside of the cabinet, allowing easy one-wrench connection of units. The large condensate connection provides proper condensate removal.



# Flexible Cabinet Configurations



# Vertical Unit Features and Benefits

## Enfinity Vertical Units Available in Four Cabinet Sizes



### Cabinet

The Enfinity™ Vertical Water Source Heat Pump is factory assembled and tested for reliability. Four unique cabinet sizes make up our 1/2 through 5 ton (2.1 through 15.0 kW) vertical heat pump product line. The consistent shape makes layout simple. Water, condensate and duct connections are all in similar locations to simplify installation.

The fan section is separated from the compressor section with an insulated divider panel for maximum sound attenuation. A large removable panel provides easy service access to the blower and motor.

The cabinet is constructed of unpainted, G-60 galvanized steel. The interiors of the top and side panels and the bottom of the unit are covered with 1/2" thick (13 mm), 1 1/2 lb. (681 g) density coated glass fiber.

### Cabinet Configurations

For maximum flexibility, each vertical unit is available in either a left-hand or right-hand return air arrangement to provide the optimum piping location and service access.

Whether working around obstacles or laying out units down a corridor, the mirror image design of the units lets you configure the system using minimum ductwork and piping. This helps reduce design, material and installation costs.

### Low Design And Installation Costs

- Two configurations for each unit size (left or right return) allow you to specify units to fit space requirements and to design the system using minimum ductwork and piping.
- Four cabinet sizes, each with McQuay's small footprint design, make it easy to meet the space requirements of your new construction or replacement application.
- Flush FPT water fittings allow easy, one-wrench connection of units and help reduce delays caused by shipping damage.

### Easy, Low-Cost Maintenance

- Easy access to the unit compressor (2-sides), fan section (1-side), motor (1-side) and unit controls (front access).

- A removable orifice ring allows the blower and motor to be removed without removing the blower housing or disconnecting the unit from the ductwork.

### Quiet, Environmentally Friendly Operation

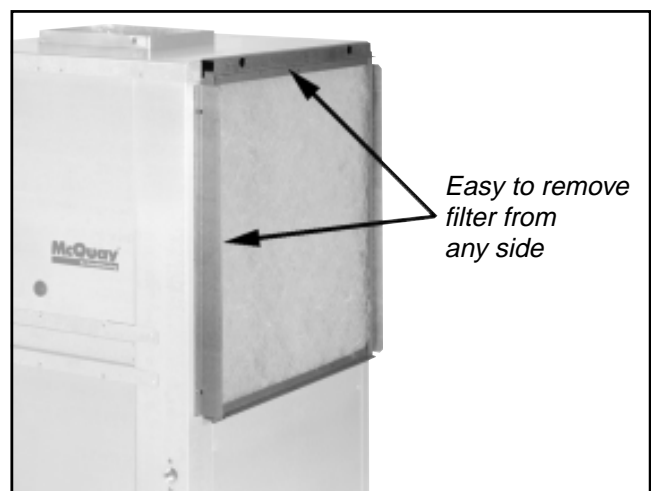
- Large fan wheel allows the fan motor to operate at lower speed for quieter operation.
- Three quiet compressor selections (depending on voltage and size variations) including rotary (sizes 007 to 012), reciprocating (sizes 019 to 024) and scroll compressors (sizes 030 to 060).
- R-410A refrigerant (sizes 019 to 060) is classified in ASHRAE standard 31 as lower toxicity, no flame propagation, non-ozone depleting HFC refrigerant.
- R-22 refrigerant (sizes 007 to 012) is classified in ASHRAE standard 31 as lower toxicity, no flame propagation, non-ozone depleting HFC refrigerant.
- Optional mass plates under compressor for noise sensitive option.

### Filter Rack

The filter is supported by factory mounted brackets that allow for face removal. Units come standard with a 1" (25.4 mm) thick throwaway filter mounted in a combination filter rack and return air duct collar, thus eliminating field mounted brackets. The filter can be removed from any of the four sides or from the front.

- Optional 2" filter rack kit for higher filtration efficiency applications.

### Filter Mounting Brackets

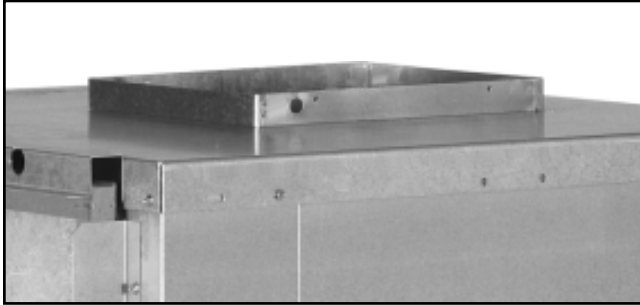


# Vertical Unit Features and Benefits

## Blower Housing

The blower housing protrudes through the cabinet top allowing adequate material for connection to a flexible duct.

*Fan Housing Protrudes Through the Cabinet Top for Connection of Flexible Duct*

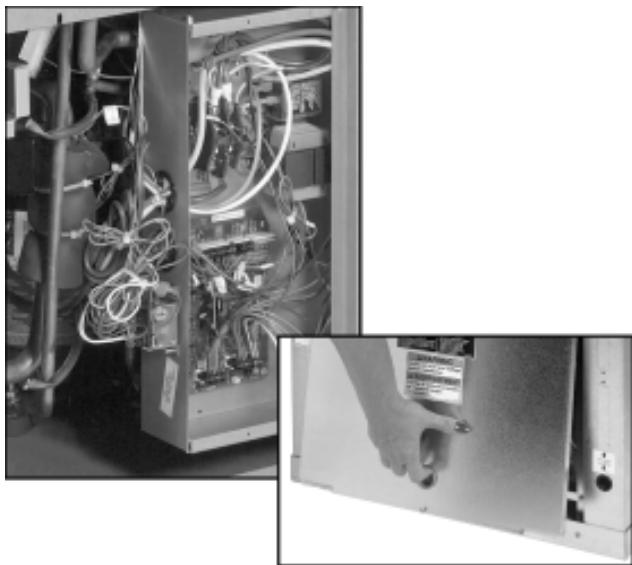


## Electrical

The electrical components are located in the compressor section of the unit. Separate holes are provided on the cabinet to facilitate main power and low voltage control wiring. All wiring connections are made internal to the cabinet to reduce the risk of accidental contact. Each unit is rated to accept time-delay fuses for branch circuit overcurrent protection. Single phase units are also rated for use with HACR circuit breakers.

The control box houses the major operating electrical controls including the control circuit board, transformer, compressor relay and fan relay. Each component can be accessed easily for service or replacement.

*Easy Access to the Vertical Unit Control Panel*



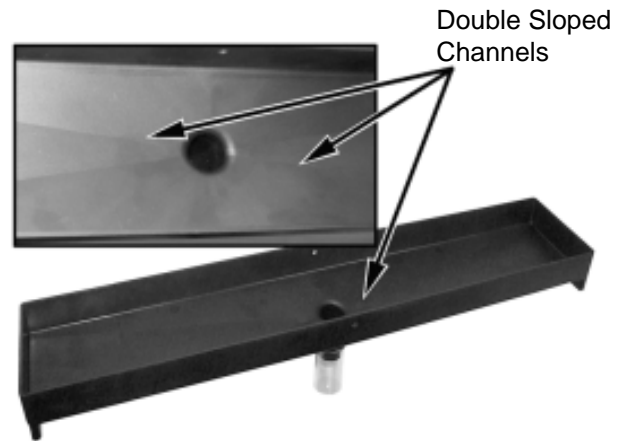
## Water Connections

The water and condensate connections are FPT fittings, securely mounted flush to the corner post to allow for connection to a flexible hose without the use of a back-up wrench. This helps reduce the time required to connect the unit and helps prevent delays due to shipping damage. All vertical units are internally trapped with clear vinyl tubing, to allow inspection of condensate drain.

*Flush FPT Water Fittings*



*Vertical Unit Double-Sloped Drain Pan*

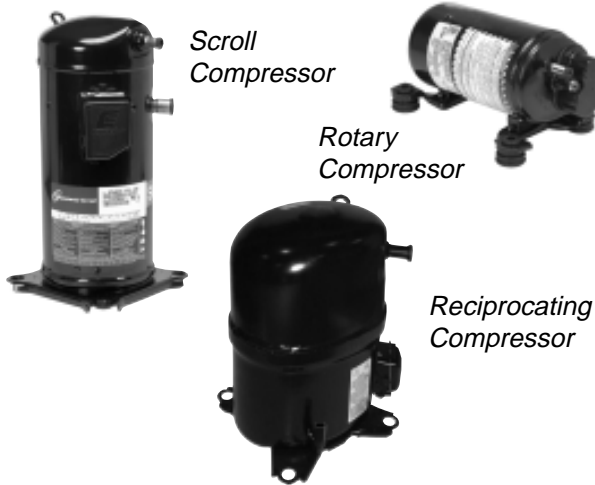


# Enfinity™ Product Features

## Compressor

McQuay Enfinity water source heat pumps are designed around the most advanced compressors in the industry. A wide variety of compressor types are used to offer the best system design for the dedicated refrigerants and tonnage. This allows McQuay Enfinity water source heat pumps to deliver the widest selection of non-CFC refrigerants, while delivering the rated capacity with low noise levels.

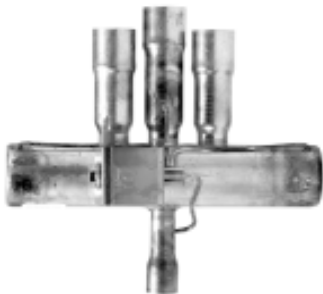
R-410A, non-CFC refrigerant is used in unit sizes 019 to 060. Unit sizes 007 to 012 use R-22 refrigerant together with proven Rotary compressor technology. Unit sizes 019 to 024 use a Reciprocating type compressor. Unit sizes 030 to 060 use a scroll compressor.



## Reversing Valve

A 4-way reversing valve is included with all McQuay Enfinity water source heat pumps. The valve is energized in the heating mode and will “fail-safe” to the cooling mode which is the predominant mode of operation for commercial applications.

### 4-Way Reversing Valve



## Thermal Expansion Valve

All McQuay Enfinity water source heat pump units include a thermal expansion valve for refrigerant metering. The Thermal Expansion Valve (TXV) allows the unit to operate at optimum efficiency with fluid temperatures ranging from 25°F to 110°F, and entering air temperatures ranging from 40°F to 90°F. The TXV precisely meters the exact amount of refrigerant flow through the system to meet the load and deliver rated heating and cooling capacity.

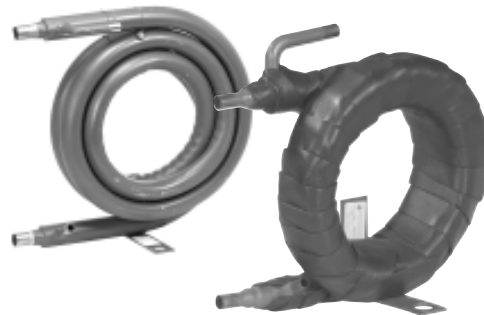
### Thermal Expansion Valve (TXV)



## Fluid-to-Refrigerant Coil

The copper or cupronickel (optional) tube-in-tube coaxial heat exchanger used in McQuay Enfinity water source heat pumps are designed for maximum heat transfer at normal and low water flow rates with minimum pressure drop. The inside tube is deeply fluted to enhance heat transfer and minimize fouling. All coaxial coils are tested to 400 psig on the water side and 500 psig on the refrigerant side. Extended range (CCW) units include coil and piping insulation to protect against condensation in low-temperature geothermal applications.

### Coaxial Heat Exchanger



# Enfinity™ Product Features

## Schrader Connections

Two Schrader valves are located inside the end access panel – one on the low side and one on the high side of the refrigeration circuit – for charging and servicing. All valves are 7/16" SAE fittings regardless of refrigerant type.

### *Schrader Valve*



## Air-to-Refrigerant Coil

The air-to-refrigerant heat exchanger is a large face area coil with copper tubes and aluminum fins. The fins are lanced and mechanically bonded to the tubes using finned edges on the inside which expand during assembly to enhance heat transfer capabilities. The maximum working pressure of the heat exchanger is 500 psig (3447 kPa). The coil is designed for optimal performance in both heating and cooling while maintaining the benefit of a compact size.

## Refrigeration System

Units have a coaxial heat exchanger with a copper inner tube and a steel outer tube. The air coil is a large face area coil with copper tubes and aluminum fins. Safety controls include high-pressure and low-temperature switch to lock out compressor operation at extreme conditions. For additional protection, units have a 7 psi (48 kPa) low-pressure switch to protect the compressor from low refrigerant charge. The low setting prevents nuisance trips while providing additional protection.

## Blower Section

The blower section includes the blower housing, wheel, motor and drain pan. It is separated from the compressor section by an insulated divider panel for maximum sound attenuation. The large size of the blower wheel allows it to rotate more slowly, reducing motor work to improve efficiency and provide for quiet operation. A large panel provides service access to the blower and motor. All blower/motor assemblies have a removable orifice ring on the housing to accommodate motor and blower removal without disconnecting the unit from the ductwork.

For maximum flexibility, the fan discharge on the horizontal unit can exit from the end or side of the unit. This can be configured at the factory or field-converted using interchangeable side and end panels.

## Blower Motor

The blower motor is a multi-speed, Permanent Split Capacitor (PSC) type with thermal overload protection. It is permanently lubricated. All motors are factory wired to maximize performance and efficiency. Unit sizes 019 and larger have a terminal strip on the motor for simple motor speed change without going back to the control box. The motor is isolated from the fan housing using rubber isolators to minimize vibration transmission. All blower/motor assemblies have a removable orifice ring on the housing to accommodate motor and blower removal without disconnecting the unit from the ductwork.

### *High Efficiency Blower Motor*



## Drain Pan

All McQuay Enfinity heat pumps come standard with a corrosion-resistant plastic drain pan to promote good indoor air quality. The pan is double-sloped for positive draining to reduce the occurrence of standing water and microbial growth.

### *Enfinity Vertical and Horizontal Unit Drain Pans*







# Control Options – 3 Unique Control Systems

The control box is accessible through a panel on the front of the unit. It houses the major operating electrical controls including the control circuit board, transformer, compressor relay and fan relay. Each component is easily accessed for service or replacement.

Three unique control systems are offered with McQuay water source heat pumps. Mark IV/AC, MicroTech™ 2000 (LONWORKS®) or BACnet® unit controllers all provide microprocessor-based control. Each option features direct quick-connect wiring to all unit-controlled components for “clean” wiring inside the control box. Each control circuit board re-

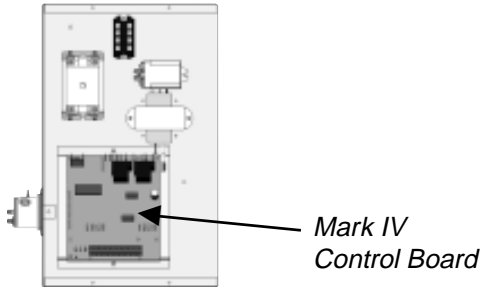
ceives power from a 50 VA transformer.

The Mark IV/AC unit controllers can communicate to a higher level building automation system (BAS) by others or a McQuay MicroTech Loop Water Control (LWC) panel via hardwired terminal strip only. The MicroTech 2000 unit controller is capable of communicating via LonTalk® protocol to a LONWORKS communications network by others. The BACnet unit controller is capable of communicating via BACnet protocol to a BACnet BACtalk® BAS communications network by Alerton.

Control	Description	Application	Protocol
 <p><i>Mark IV</i></p>	The Mark IV/AC control board is a microprocessor-based control board conveniently located in the unit control box for accessibility, with a 14-pin low voltage terminal strip.	McQuay heat pumps with Mark IV/AC controllers are designed to operate as a stand alone communication network. Mark IV unit controls are not designed for integration with a centralized BAS.	Standalone
 <p><i>MicroTech 2000</i></p>	The MicroTech 2000® unit controller provides control of McQuay and AAF water source heat pumps. The controller enables the mode of operation, monitors the water and air temperatures, and indicates fault conditions. Each unit controller is factory programmed, wired, and tested for effective operation of your McQuay WSHP. The MicroTech 2000 WSHP controller uses LONWORKS® technology. One of the following two versions of the application software is loaded into the controller at the factory.	1. LonMARK® application code, used in new applications including: <ul style="list-style-type: none"> <li>• Units that operate stand alone.</li> <li>• Units that are integrated into LONWORKS communication network for communicating with a building automation system (BAS) of your choice.</li> </ul>	LONMARK
		2. LonTalk® application code, used in existing systems where: <ul style="list-style-type: none"> <li>• MicroTech 2000 WSHPs connect to a McQuay MicroTech monitor through a MicroTech Communication Gateway (MCG panel).</li> <li>• MicroTech 2000 WSHPs connect to a third party BAS system through a MicroTech Communications Gateway for Open Protocol (MCGOP) panel.</li> </ul>	LonTalk
 <p><i>BACnet</i></p>	The BACnet unit controller is microprocessor-based and is designed to communicate over a BACnet communications network. The unit controller is factory mounted, programmed and tested with all logic required to monitor and control the unit. The controller sets the unit mode of operation, monitors water and air temperatures, and can communicate fault conditions to a BACnet communications network.	McQuay Enfinity water source heat pumps with BACnet controllers are designed to be linked with an Alerton BACtalk centralized building automation system through a BACnet communications network for centralized scheduling and management of multiple heat pumps.	BACnet (Alerton BACtalk BAS)
 <p><i>Loop Water Controller</i></p>	The Loop Water Controller (LWC) is a standalone, factory programmed and tested microprocessor-based controller providing control of the heat rejection/heat addition stages and the water circulating pumps for control of a water source heat pump system through solid-state output relays. The controller includes a keypad and display to view all status conditions, temperatures, setpoints and alarm conditions.	Used in traditional single loop systems; closed-circuit evaporative cooler, boiler, primary pump and standby pump systems; or two-loop systems with the heat pump loop having a boiler, primary pump and standby pump separated by a water-to-water heat exchanger to a condenser water loop with an open cooling tower, primary (stage 1) pump and a standby (stage 2) pump.	Standalone (designed to communicate with Mark IV unit controllers). Mark IV unit controls are not designed for integration with a centralized BAS.

# Control Features – Mark IV/AC Control System

The Mark IV/AC control system is a microprocessor-based control board conveniently located in the unit control box for accessibility. Mark IV/AC controllers include a 14-pin low voltage terminal strip for a hardwired interface for all the necessary field connections. LED's are located in front for quick inspection. The board can be wired for 24-volt AC output to the wall thermostat by using terminals R & C. If a DC voltage output to the thermostat is required, use terminals F & V. This allows you to choose the control output voltage to accommodate controls by others or accessories.



The Mark IV/AC control system has the following operating features (assumes cycle fan operation-not continuous fan operation):

- **Start-up** – The unit will not operate until all the inputs and safety controls are checked for normal conditions.
- **Cooling mode** – On a call for cooling, the compressor and fan will start 0 to 32 seconds later. When the load is satisfied, the compressor and fan shut off immediately.
- **Heating Mode** – On a call for heating, the reversing valve is energized after 60 seconds and the compressor and fan start immediately. When the load is satisfied, the compressor and fan shut off immediately. The reversing valve is de-energized 60 seconds later to eliminate “swish” noise and to allow the compressor to always start up at equalized pressure.
- **Short Cycle Protection & Random Start** – Each time the compressor stops, a new random compressor start-delay time between 180 and 212 seconds is generated. This prevents compressor short cycling and prevents units from starting simultaneously after coming back from an unoccupied cycle.
- **Unoccupied Mode** – A simple “grounded” signal, no power source required, puts the unit into the unoccupied mode for night setback operation. The fan shuts off and the unit controls to the setpoint from the setback bulb of the thermostat. The day heating thermostat control and cooling is locked out. A unique LED status is generated to indicate the unoccupied mode. On a call for heating, the fan and the compressor start after 60 seconds.
- **Override Mode** – A switch on the deluxe automatic changeover thermostat can be activated during the unoccupied mode to put the unit back into the occupied mode for two hours for after-hours heating or cooling.
- **Pump Restart** – A signal from the Mark IV/AC board to our Loop Water Control Panel will restart the water circulating loop pump when the compressor is energized. The signal can be “daisy chained” between 200 units.

- **Load Shed** – A simple grounded signal puts the unit into the load-shed mode. The compressor shuts off and the fan starts on a call for heating and cooling. A unique LED status is generated to indicate the load-shed mode.
- **Brownout Protection** – The Mark IV/AC board measures the input voltage and will suspend compressor and fan operation if the voltage falls below 80% of the normal line voltage. A unique LED status is generated and an output is available to a “fault” LED at the thermostat.
- **Unit Shutdown** – A simple grounded signal puts the unit into the shutdown mode. Compressor and fan operations are suspended. A unique LED status is generated and an output signal is made available for connection to a “fault” LED at the thermostat.
- **Condensate Overflow Protection** – The Mark IV/AC board incorporates a liquid sensor at the top of the drain pan. Upon sensing water flow, cooling operation is suspended. A unique LED status is generated and output is available to a “fault” LED at the thermostat. Heating operation is not suspended.
- **Remote Reset of Automatic Lockouts** – The Remote Reset feature provides the means to remotely reset automatic lockouts generated by high-pressure and/or low-temperature (in heating) faults. When the Mark IV board is in automatic lockout due to one of these faults, and the cause of the fault condition has been alleviated, energizing the O-terminal for 10 seconds or more will force the Mark IV board to clear the lockout. A unit power cycle can also be used to clear an automatic lockout if the conditions causing the fault have been alleviated.
- **Fault Retry To Minimize Nuisance Trips** – The Fault Retry feature helps to minimize nuisance trips of automatic lockouts caused by high-pressure and/or low-temperature (in heating) faults. This feature clears faults the first two times they occur within a 24-hour period and triggers an automatic lockout on the 3rd fault. The retry count is reset to zero every 24 hours.

**NOTE:** Most unit fault conditions are the result of operating the equipment outside the unit specifications.

- **Equipment Protection Control** – The Mark IV/AC board receives separate input signals from the refrigerant high-pressure switch and the low suction temperature (freezestat) switch. In a high-pressure situation, compressor operation is suspended. In a low temperature situation, the unit goes into a defrost cycle where the unit is put into cooling operation for 60 seconds until the co-axial heat exchanger is free of ice. Each switch generates its own unique LED status and output is available to a “fault” LED at the thermostat if either situation exists. For additional protection, units have a 7psi (48 kPa) low pressure switch to protect the compressor from low refrigerant charge. The low setting prevents nuisance trips while providing additional protection.

# Control Features – MicroTech™ 2000 Controller

Mark IV/AC LED & fault outputs

Indication	LED			Fault Output
	Yellow	Green	Red	
Normal Mode	Off	On	Off	Off
Pressure Fault	Off	On	Flash	On
Low Temperature Fault*	Flash	Off	Off	On
Condensate Overflow**	On	Dim	Off	On
Brownout	Off	Flash	Off	On
Load Shed	Off	Off	On	Off
Unoccupied Mode	On	On	Off	Off
Unit Shutdown	Off	Flash	Off	On

\* Only in the heating mode    \*\* Only in the cooling mode

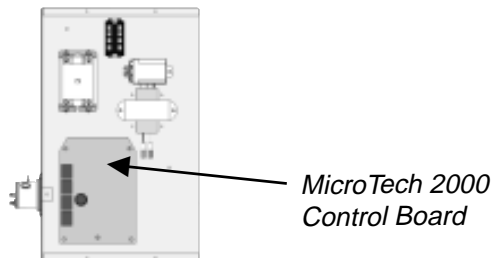


MicroTech 2000 heat pumps are LONMARK certified and are designed to be linked with a centralized building automation system through a LONWORKS communications network for centralized scheduling and management of multiple heat pumps. Wall-mounted room sensors are available to control the heating and cooling operation of each MicroTech 2000 Water Source Heat Pump Unit Controller. Available room sensors include: room sensor with LED status and tenant override button, room sensor with LED status, timed-override button, and bi-metal thermostat, room sensor with LED status, timed-override button, and setpoint adjustment, and room sensor with LED status, timed-override button, setpoint adjustment and bi-metal thermostat.

## MicroTech™ 2000 Controller

Each McQuay water source heat pump can be equipped with a MicroTech 2000 water source heat pump unit controller. The controller is microprocessor-based and is designed to communicate over a LONWORKS communications network. The unit controller is factory programmed and tested with all the logic required to monitor and control the unit. The controller sets the unit mode of operation, monitors water and air temperatures, and can communicate fault conditions to a LONWORKS communications network.

The MicroTech 2000 unit controllers include unit-mounted return air, discharge air and leaving water temperature sensors. Options include a tenant setpoint adjustment knob and tenant override button, and the capability of substituting the return air sensor with a wall-mounted room sensor.



Each unit controller orchestrates the following unit operations:

- Enable heating and cooling to maintain setpoint based on a room sensor.
- Enable fan and compressor operation.
- Monitor all equipment protection controls.
- Monitor discharge air temperature.
- Monitor leaving water temperature.
- Relay status of all vital unit functions.
- Support optional control outputs.

An amber, on-board status LED aids in diagnostics by indicating the water source heat pump operating mode and alarm conditions. If there are no current alarm conditions, the LED will indicate the unit operating mode as shown in the table below. If there are one or more alarm conditions present, the LED will flash to indicate an alarm condition.

The MicroTech 2000® WSHP unit controller provides control of McQuay and AAF water source heat pumps. The controller enables the mode of operation, monitors the water and air temperatures, and indicates fault conditions. Each unit controller is factory programmed, wired, and tested for effective operation of your McQuay WSHP.

The MicroTech 2000 WSHP controller uses LONWORKS® technology. One of the following two versions of the application software is loaded into the controller at the factory.

**LONMARK® 3.3 certified application code** is the current standard application code for MicroTech 2000 units. Use LONMARK application code in new applications including:

- Units that operate stand alone.
- Units that are integrated into a LONWORKS communication network for communicating with a building automation system (BAS) of your choice.

For network integration information, refer to the Protocol Information document ED 15054.

Unit controllers with LONMARK application code have a software identification of WHPE2E or higher.

**LonTalk® application code** was designed prior to certification. Use this application software only in existing systems where an existing MicroTech Communications Gateway (MCG) or MicroTech Communications Gateway for Open Protocol (MCGOP) panel is installed. Use LonTalk application code in existing systems where:

- MicroTech 2000 WSHPs connect to a McQuay MicroTech monitor through a MicroTech Communication Gateway (MCG panel).
- MicroTech 2000 WSHPs connect to a third party BAS system through a MicroTech Communications Gateway for Open Protocol (MCGOP) panel.

If you choose to upgrade your heat pumps, the other application code can be installed in the field.



# Control Features – BACnet for Alerton BACtalk

## MicroTech 2000 Unit Controller LED Indication

Status LED State	Mode
On Continually	Occupied, Occupied Load Shed
On ½ sec., Off 5 ½ sec.	Unoccupied
On 5 ½ sec., Off ½ sec.	Tenant Override, Override Load Shed
Flashing	Alarm Condition

LONMARK and the LONMARK logo are trademarks of Echelon Corporation in the United States and other countries.

## BACnet for Alerton BACtalk

McQuay Enfinity water source heat pumps are available with a factory mounted and tested McQuay BACnet unit controller. The unit controller is factory programmed and tested with all the logic required to control the unit, and is designed to communicate over a native BACnet MS/TP communications network to a BACtalk building automation system (BAS). The controller operates the compressor, fan, and reversing valve as required to maintain the space temperature within the current setpoints. Data regarding equipment status, water and air temperatures, and fault conditions can be monitored by any native BACtalk BAS. Setpoints and other system preferences may be changed remotely using an Alerton BACtalk workstation or Alerton service tool software.

The controller makes operational data and commands available on the McQuay BACtalk network using BACnet objects and properties. Each heat pump controller connects to the BACtalk network using a BACnet MS/TP communication network, which is a simple twisted-pair communications connection that operates at up to 76.8 Kbps. DIP switches on the controller enable the MS/TP MAC address to be set in the range 0-127. A status LED on the unit indicates communication activity on the MS/TP communication network.



BACnet Water Source Heat Pump Controller

Each BACnet-compliant unit includes discharge air and leaving water temperature sensors, as well as all equipment protection sensors, signals, and switches. Wall-mounted room sensors are available to control heating and cooling operation. Available sensors include tamper-resistant stainless steel wall sensors with optional push-button for status override; wall-mounted sensors with tenant setpoint adjustment lever and timed-override button; wall-mounted sensors with LED status, timed-override button, tenant setpoint adjustment buttons, password-protected field service access to operational data, and optional humidity sensor; and wall-mounted sensors with LCD and programmable operation.

Each BACnet-compliant controller has the following operating features:

- **Start-up** – The unit will not operate until all the inputs and safety controls are checked for normal conditions.
- **Fan operation** – Fan operation can be customized in software to run continuously during occupied mode, or to cycle ON or OFF appropriately on a call for heating and cooling.
- **Cooling mode** – On a call for cooling, the compressor and fan start immediately. Compressor run-time is calculated as a percent of full cycle time (17 minutes) using proportional-integral control to maximize efficiency.
- **Heating mode** – On a call for heating, the compressor and fan start immediately, and compressor run-time is calculated as a percent of full cycle time (17 minutes) using proportional-integral control to maximize efficiency.
- **Short Cycle Protection and Random Start** – A start delay of 180 seconds plus the compressor’s MAC address in seconds prevents short-cycling and simultaneous start-up. A minimum 2-minute on time and 5-minute off time for the compressor further ensures short-cycle protection.
- **Occupied Mode** – A simple software control signal from the building automation system or a wall-mounted unit puts the unit into occupied mode. The unit controls compressor and fan operation to maintain occupied setpoints. High and low limits for occupied setpoints are software configurable.
- **Unoccupied Mode** – A simple software control signal from the building automation system or a wall-mounted unit puts the unit into unoccupied mode for night set-back operation. The unit controls compressor and fan operation to maintain unoccupied heating and cooling setpoints, which are also software configurable.
- **After-hours Override Mode** – A simple software control signal from the building automation system or a wall-mounted unit can initiate after-hours heating or cooling in half-hour increments. Maximum override time is software configurable up to 9.5 hours. This feature can also be disabled in software.

# Control Features – BACnet for Alerton BACtalk

---

- **Reversing valve delay** – When the compressor turns off after heating mode, the reversing valve remains energized for 60 seconds before it returns to the normal cooling position to eliminate swishing. The reversing valve energizes 10 seconds before the compressor.
- **Load Shed** – Load shedding can be orchestrated by the building automation system using the occupied/unoccupied command in software.
- **Brownout Protection** – An on-board sensor measures input voltage and suspends compressor and fan operation if the supply voltage drops below 82% of the normal line voltage for a minimum of 10 seconds, creating an alarm available in software. The alarm automatically resets when the supply voltage returns to above 90% of normal.
- **Condensate Overflow Protection** – A liquid sensor at the top of the drain pan senses a high water level. Upon sensing water, cooling operation is suspended, while heating operation is allowed. The controller creates an alarm available in software. The alarm automatically resets when the water level returns to normal.
- **Safety Control** – The unit monitors refrigerant pressure and generates separate high-pressure and low-pressure alarms available in software. While either alarm is active, compressor operation is suspended. In a refrigerant low-temperature condition, an alarm occurs and the unit operates in cooling mode for 60 seconds to defrost the heat exchanger, after which compressor operation is suspended. These alarms can be reset in software or by cycling power to the controller.
- **Attained Temperature and Water Temperature Alarms** – Attained temperature, water temperature alarms with software-adjustable setpoints are available in software. The controller samples supply air and records attained temperatures for heating and cooling. If after two hours of operation, the attained temperature does not meet the software-configurable setpoint for heating or cooling as appropriate, a software alarm occurs. The alarm automatically resets when the attained temperature is within setpoints. The controller also monitors leaving water temperature. If the leaving water temperature is outside software-configurable setpoints, compressor operation is suspended and high or low water temperature alarms occur. The alarm automatically resets when the water temperature returns to within 6 deg. F of the setpoint.
- **Unit Self-test Mode** – While the unit is in occupied mode, a self-test can be initiated via software. Upon initiation of the test, compressor operation is suspended for a minimum of five minutes, cooling attained temperatures are cleared, and attained temperature alarms are cleared. The unit then switches to full heat for four minutes and then records the attained supply air temperature. Compressor operation is then suspended for five minutes. The unit then switches to full cooling for four minutes and the attained supply air temperature is recorded. Attained temperature alarms are set if the attained temperatures failed to reach alarm setpoints during heating or cooling.

# Control Features – Loop Water Controller

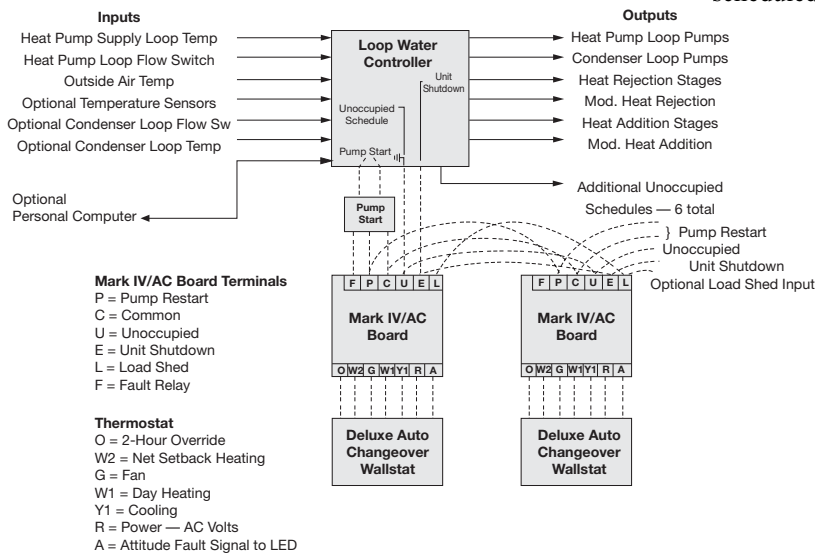
The Loop Water Controller (LWC) is a stand-alone, factory programmed and tested microprocessor-based controller. It controls the heat-rejection/heat-addition stages and the water circulating pumps of a water source heat pump system through solid-state output relays. The controller includes a keypad and display to view all status conditions, temperatures, setpoints and alarm conditions. The display is two lines by sixteen columns and supports a supertwist LCD format. The LWC is designed to be used with the Mark IV unit controllers for standalone operation of the water loop. The LWC does not support serial communications with a higher level BAS.



The LWC can be used in any of the following applications:

- A traditional single-loop system
- A closed-circuit evaporative cooler, boiler, primary pump and standby pump system
- A two-loop system with the heat pump loop having a boiler, primary pump and standby pump. This is separated by a water-to-water heat exchanger from a condenser water loop with an open cooling tower, primary (stage 1) pump and a standby (stage 2) pump. The pumps can be operated as “auto” or “manual” lead-lag. Pump sequencing allows the standby pump to automatically come on upon failure of the lead pump as indicated by a flow switch.

## Mark IV/AC Interface



The LWC can control heating and cooling stages from the heat pump loop-supply temperature and from the outdoor air temperature for reset of the heat-addition setpoint. Other temperatures that can be monitored include: the heat pump loop return temperature, the entering and leaving tower temperatures, the entering and leaving boiler temperatures, and the storage tank temperature.

Clock schedule outputs are built-in to:

- (1) control the heat pump circulating pump for shutdown at night (can be restarted if outdoor air temperature falls below the setpoint) and
- (2) provide programmable time schedules for heat pump unit occupied/unoccupied operation. A maximum of six time clock schedule outputs are available.

Two LWC models are available. The LWC-16 and LWC-24 provide 9 and 17 configurable outputs, respectively, choosing between heat rejection (cooling) stages, heat addition (heating) stages and time clock schedules. Each heating and cooling output has individual on and off (differential) setpoint adjustment capability. Modulating heating and cooling output signals are available to control tower bypass and two-way or three-way boiler heat addition valves.

Monitored system points include visual and audible notification of low water temperature, high water temperature, and no flow conditions. When an alarm condition occurs, the LWC closes contacts which can be tied to an emergency shutdown signal. A remote alarm panel is available for alarm notification at a remote location. The LWC interfaces with Mark IV/AC controlled heat pump units for a low-cost control system. The Mark IV/AC board can receive occupied/unoccupied time clock schedule outputs and an emergency shutdown signal due to an alarm condition. The LWC can receive a signal (pump restart) from the Mark IV/AC board to energize and override the main circulating pump (if it is scheduled off) whenever a compressor operates from a call for night setback heat or from a call for heating or cooling during the two-hour override cycle.

Simple “daisy chain” wiring is required between Mark IV/AC board terminals on each water source heat pump.

Additional features include a built-in test mode to simulate all control modes, a pre-cool cycle to enable heat rejection earlier for undersized boilers, a preheat cycle to enable heat addition earlier for undersized towers, keypad password protection, and holiday scheduling.

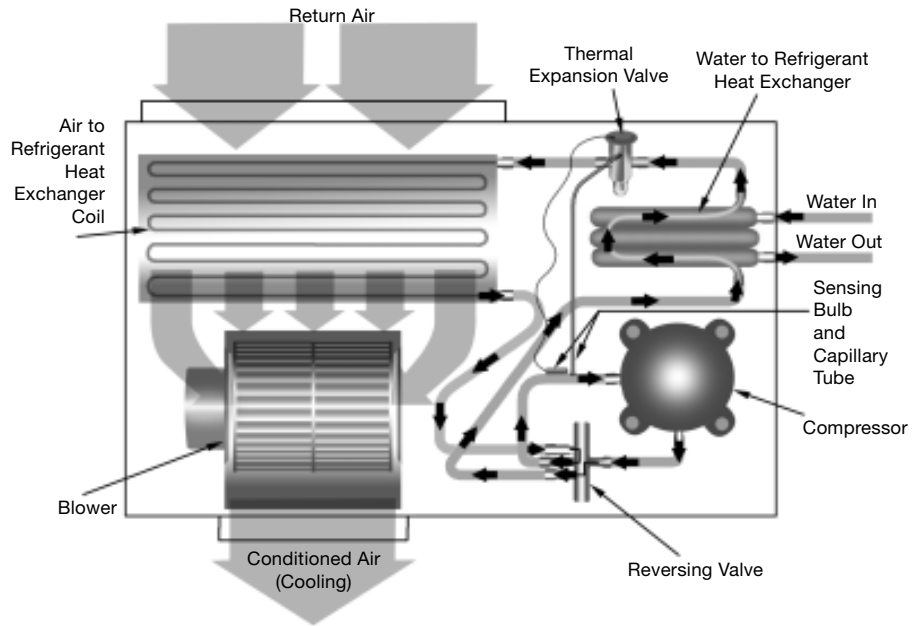
The LWC panel is not designed to communicate with a higher level BAS.

# Applications – Systems

## Cooling and Heating Refrigeration Cycles

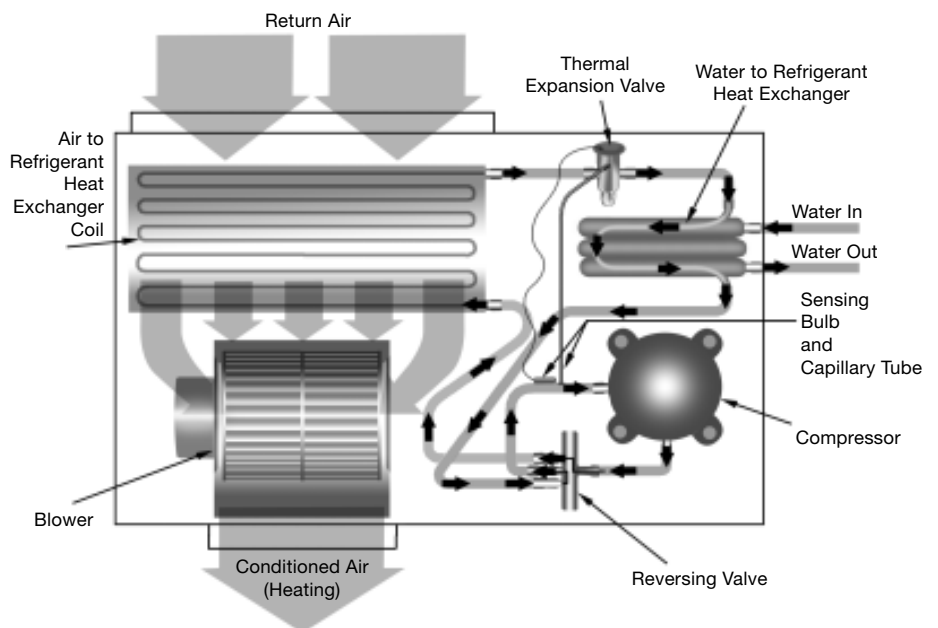
### Cooling Refrigeration Cycle

When the wall thermostat calls for COOLING, the reversing valve directs the flow of the refrigerant, a hot gas, from the compressor to the water-to-refrigerant heat exchanger. There, the heat is removed by the water, and the hot gas condenses to become a liquid. The liquid then flows through a thermal expansion valve to the air-to-refrigerant heat exchanger coil. The liquid then evaporates and becomes a gas, at the same time absorbing heat and cooling the air passing over the surfaces of the coil. The refrigerant then flows as a low pressure gas through the reversing valve and back to the suction side of the compressor to complete the cycle.



### Heating Refrigeration Cycle

When the wall thermostat calls for HEATING, the reversing valve directs the flow of the refrigerant, a hot gas, from the compressor to the air-to-refrigerant heat exchanger coil. There, the heat is removed by the air passing over the surfaces of the coil and the hot gas condenses and becomes a liquid. The liquid then flows through a thermal expansion valve to the water-to-refrigerant heat exchanger. The liquid then evaporates and becomes a gas, at the same time absorbing heat and cooling the water. The refrigerant then flows as a low pressure gas through the reversing valve and back to the suction side of the compressor to complete the cycle.



# Applications – Systems

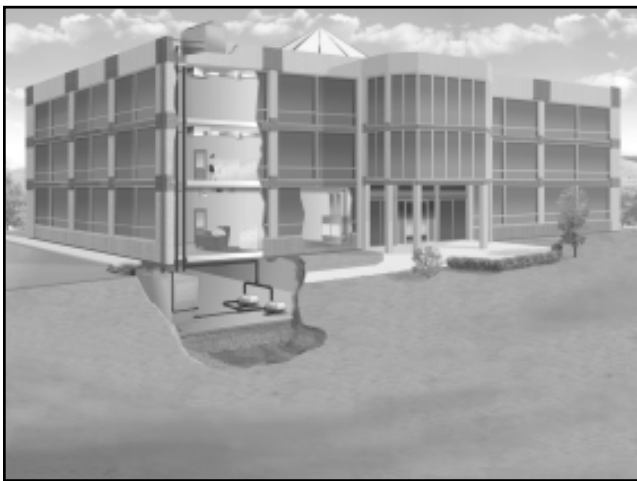
Water source heat pump systems are one of the most efficient, environmentally friendly systems available for heating and cooling buildings. High-efficiency, self contained units (sizes 7,000 btuh to 290,000 btuh) can be placed in virtually any location within a building. Each unit responds only to the heating or cooling load of the individual zone it serves. This permits an excellent comfort level for occupants, better control of energy use for building owners and lower seasonal operating costs. The Air-Conditioning Refrigeration Institute (ARI) and the International Standards Organization (ISO) publish standards so that water source heat pumps are rated for specific applications. The ARI/ISO loop options shown in this catalog are typical water source heat pump loop choices available in today’s market. These systems offer benefits ranging from low cost installation to the highest energy efficiency available in the market today.

## Boiler / Tower Applications: ARI 320 / ISO 13256-1

A “Boiler/Tower” application uses a simple two-pipe water circulating system that adds heat, removes heat or transfers rejected heat to other units throughout the building. The water temperature for heating is generally maintained between 65°F – 70°F and is usually provided by a natural gas or electric boiler located in a mechanical room. The condensing water temperature, during cooling months, is maintained between 85°F and 95°F and requires the use of a cooling tower to dissipate waste heat. Cooling towers can be located on the roof, or inside or adjacent to the building. This application can be the lowest cost of the loop options available.

**Note:** ASHRAE 90.1 standards require that circulating pumps over 10 HP will require use of “variable frequency drive” equipment and pipe insulation to be used whenever water temperatures are below 60 degrees and above 105 degrees. See ASHRAE 90.1 Standards for details.

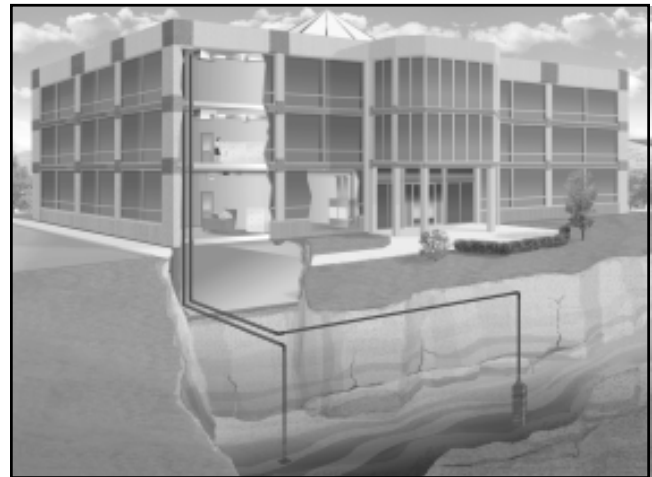
### Boiler/Tower Application



## Open Loop Well Water Applications: ARI 325 / ISO 13256-1

“Open Loop” well water systems use ground water to remove or add heat to the interior water loop. The key benefit of an open loop system is the constant water temperature, usually 50°F to 60°F, which provides efficient operation at a low first cost. Most commercial designers incorporate a heat exchanger to isolate the building loop from the well water. Using heat exchangers can reduce maintenance issues while still allowing the transfer of heat from unit to unit as with the “Boiler/Tower System”. A successful design provides an ample amount of groundwater (approximately 2 GPM per ton) and adequate provisions for discharging water back to the aquifer or surface. Open Loop applications are commonly used in coastal areas where soil characteristics allow reinjection wells to return the water back to the aquifer. Note that some states have requirements on the depths of return water reinjection wells, and such wells must be approved by the United States Environmental Protection Agency. Also, bad water quality can increase problems with heat exchanger scaling. Suspended solids can erode the heat exchanger. Strainers can be used to contain suspended solids.

### Open Loop Well Application



# Applications – Systems

## Closed Loop Geothermal Applications ARI 330/ISO 13256-1

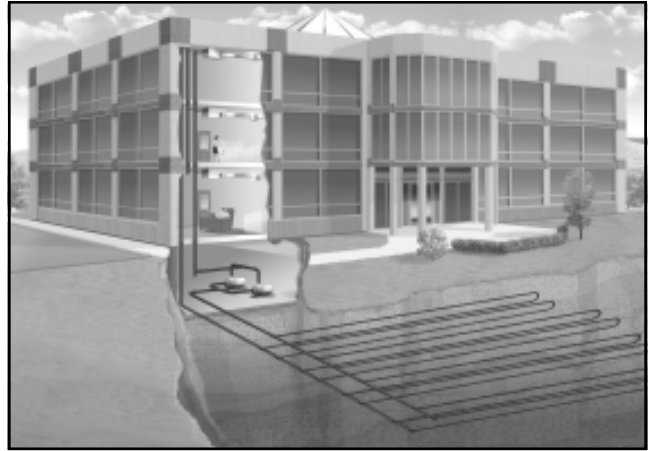
“Vertical Closed Loop” applications are installed by drilling vertical bore holes into the earth and inserting a plastic polyethylene supply / return pipe into the holes. The vertical wells are connected in parallel reverse return fashion to allow the water from the building to circulate evenly throughout the borefield. The circulating fluid dissipates heat to the ground in a similar manner as a “tower” and adds heat back to the loop like a boiler. If properly designed, the loop field can maintain the loop temperatures necessary to condition the building without the use of a boiler or a tower. Loop temperatures usually range from 37°F to 95°F in Northern climates. Southern applications can see temperatures ranging from 40°F to 100°F. The number of bore holes and their depth should be determined by using commercial software that is specifically designed for vertical geothermal applications. Typical bore depths of a vertical loop range from 150 to 400 feet and generally require about 250 feet of surface area per ton of cooling.

### Vertical Loop Application



A closed loop “Horizontal” geothermal application is similar to a vertical loop application with the exception that the loops are installed in trenches approximately 5 feet below the ground surface. The piping may be installed using a “four-pipe” or “six-pipe” design and could require 1,500 to 2,000 square feet of surface area per ton of cooling. Loop temperatures for a commercial application can range from 35°F to 95°F in Northern climates. Southern climates can see temperatures ranging from 40°F to 100°F. Horizontal loops are generally not applied in urban areas because land use and costs can be prohibitive. New advances in installation procedures have improved the assembly time of horizontal loops while keeping the first cost lower than a vertical loop.

### Horizontal Loop Application



A “Surface Water” or “Lake” closed loop system is a geothermal loop that is directly installed in a lake or body of water that is near the building. In many cases, the body of water is constructed on the building site to meet drainage or aesthetic requirements. Surface loops use bundled polyethylene coils that are connected in the same manner as a vertical or horizontal loop using a parallel reverse return design. The size and the depth of the lake is critical. Commercial design services should be used to certify that a given body of water is sufficient to withstand the building loads. Loop temperatures usually range from 35°F to 90°F and prove to be the best cooling performer and lowest cost loop option of the three geothermal loops. Some applications may not be good candidates due to public access or debris problems from flooding.

### Surface Water Loop Application



# Applications Considerations

## Typical Horizontal Unit Installation

### Unit Location

It is important to leave enough space for service personnel to perform maintenance or repair. Locate the horizontal unit to allow for easy removal of the filter and access panels. Allow a minimum of 18" (46 cm) clearance on each side of the unit for service and maintenance access and do not install the unit above any piping. Always be sure to leave at least one side of the filter rack unobstructed so that the service personnel will be able to slide the filter out. Each unit is suspended from the ceiling by four 3/8" threaded rods fastened to the unit by a hanger bracket and rubber isolator. The design should place the unit directly below the structural members so that it is securely anchored.

Avoid installing units directly above spaces where building occupants will reside (e.g. above office desks or classrooms) to reduce the requirement for noise attenuation. Do not place units above high traffic areas because service access may be limited during occupied hours. For example, units are typically installed above the hallway drop ceiling in Schools and the supply and return air is routed directly into classrooms. Local code may require fire dampers to be used with this application.

### Piping

The WSHP unit is typically connected to the supply / return piping using a "reverse return" piping system which includes a flow control device so that flow requirements are met for each zone. A short, high pressure "flexible hose" is used to connect the unit to the building's hard piping and acts as a sound attenuator for both the unit operating noise and

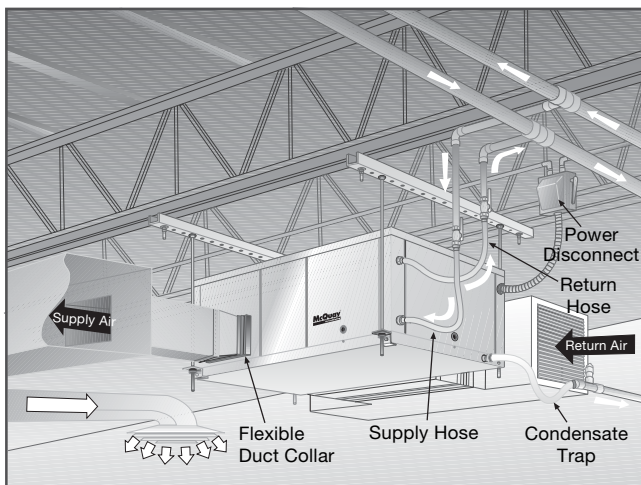
hydraulic pumping noise. One end of the hose has a swivel fitting to facilitate removal of the unit for replacement or service. Include supply and return shutoff valves in the design to allow removal of a unit without the need to shut down the entire heat pump system. The return valve may be used for balancing and will typically have a "memory stop" so that it can be reopened to the proper position for the flow required. Fixed flow devices are commercially available and can be installed to eliminate the need for memory stop shut off valves. Include Pressure / Temperature ports to allow the service technician to measure water flow and unit operation.

### Condensate Drain Piping

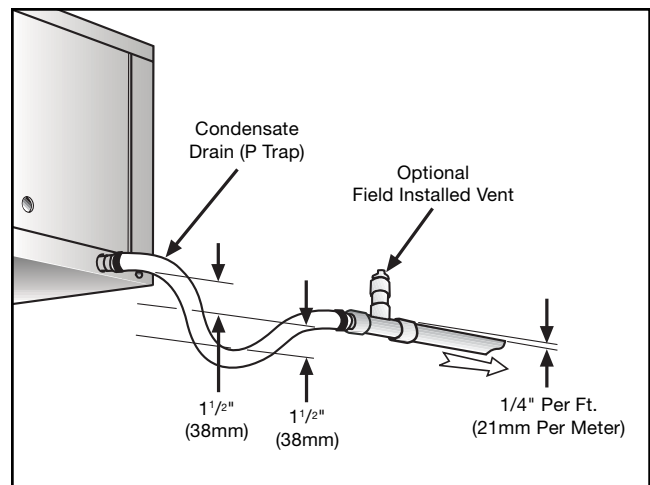
Condensate piping can be made of steel, copper or PVC pipe. In most cases, PVC pipe eliminates the need to wrap insulation around the pipe to prevent sweating. A threaded, factory supplied condensate fitting allows the connection of PVC, flexible vinyl hose or steel braided hose.

The condensate piping must be trapped at the unit and pitched away from the unit not less than 1/4" per foot. A vent is required after the trap so that the condensate will drain away from the unit. The vent can also act as a clean out if the trap becomes clogged. To avoid having waste gases entering the building, the condensate drain should not be directly piped to a drain/waste/vent stack. See local codes for the correct application of condensate piping to drains.

### Typical Ceiling Installation



### Typical Condensate Piping



# Applications Considerations

## Ductwork and Sound Attenuation Considerations

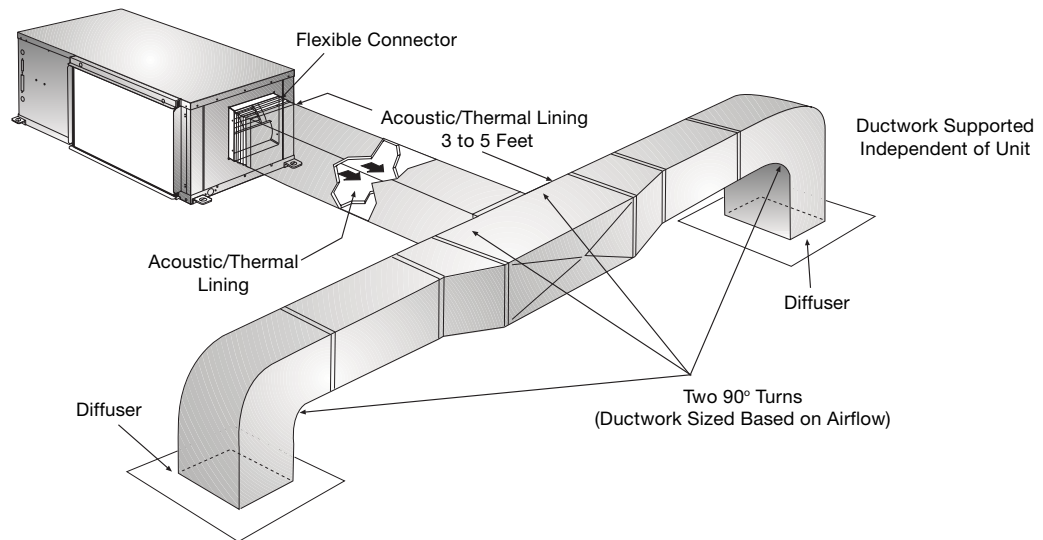
Ductwork is normally applied to ceiling-mounted heat pumps on the discharge side of the unit. A discharge collar is provided on all horizontal unit models for fastening the ductwork. Use a flexible connector between the discharge collar and the duct transformation to help with sound attenuation from the cabinet and to simplify disconnection of the unit from the ceiling ductwork. If return ductwork is to be used, attach a flexible connector to the filter rack collar to help with sound attenuation and removal of the unit. Return plenum ducting should be at least 12 inches away from the coil so that the coil is evenly loaded with return air.

As a general recommendation, duct interiors should have an acoustic / thermal lining at least 1/2 inch thick over the entire duct run. For maximum attenuation, line the last five diameters of duct before each register with a one-inch thick sound blanket. Elbows, tees and dampers can create turbulence or distortion in the airflow. Place a straight length of

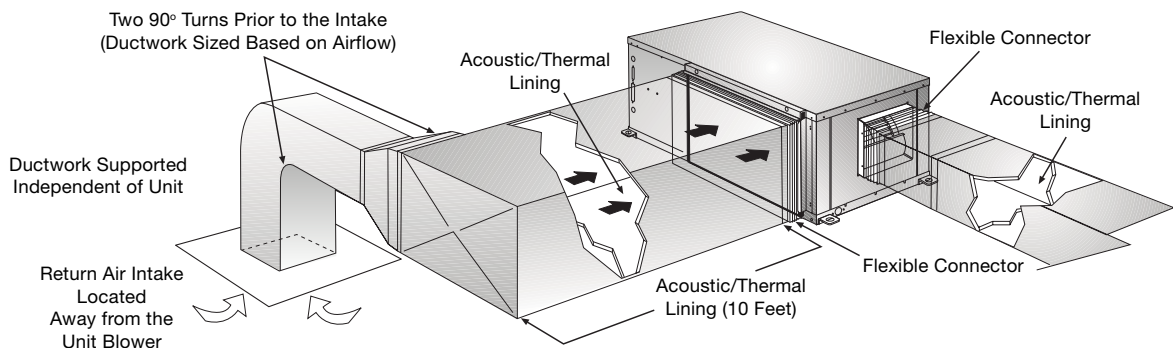
duct, 5 to 10 times the duct width, before the next fitting to smooth out airflow. Diffusers that are located in the bottom of a trunk duct can also produce noise. For this same reason, volume control dampers should be located several duct widths upstream from an air outlet.

For Hotel, Motel, Dormitory or Nursing Home applications that use a single duct discharge, a velocity of 500 to 600 fpm is suggested. These applications typically have static pressures as low as 0.05 inches of water and duct lengths approximately six feet in length. The discharge duct must be fully lined and have a square elbow without turning vanes. Return air for these applications should enter through a “low” sidewall filter grille and route up the stud space to a ceiling plenum. For horizontal heat pumps mounted from the ceiling, an attenuator box is sometimes placed at the return air opening to attenuate line-of-sight sound transmission through return openings.

### Suggested Supply Ducting per ASHRAE and SMACNA Publications



### Suggested Return Ducting per ASHRAE and SMACNA Publications





# Applications Considerations

## Typical Vertical Installation

### Unit Location

Locate a vertical unit to allow for easy removal of the filter and access panels. Allow a minimum of 18" (46 cm) clearance on each side of the unit for service and maintenance access. Always be sure to leave at least one side of the filter rack unobstructed so that the service personnel will be able to slide the filter out.

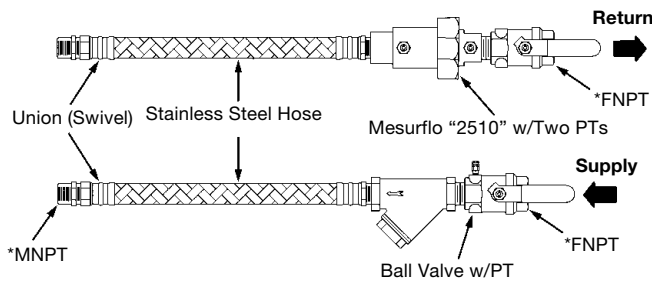
Install a field supplied line voltage disconnect for branch circuit protection.

To reduce noise attenuation, install a 1/2 inch thick, field provided vibration pad below the vertical unit. This vibration pad should be equal to the overall foot-print size of the unit to provide sound dampening of the unit while in operation.

### Piping

The WSHP unit is typically connected to the supply / return piping using a "reverse return" piping system which includes a flow control device so that flow requirements are met for each zone. A short, high pressure "flexible hose" is used to connect the unit to the building's hard piping and acts as a sound attenuator for both the unit operating noise and hydronic pumping noise. One end of the hose has a swivel fitting to facilitate removal of the unit for replacement or service. Include supply and return shutoff valves in the design to allow removal of a unit without the need to shut down the entire heat pump system. The return valve may be used for balancing and will typically have a "memory stop" so that it can be reopened to the proper position for the flow required. Fixed flow devices are commercially available and can be installed to eliminate the need for memory stop shut off valves. Include Pressure / Temperature ports to allow the service technician to measure water flow and unit operation.

### Fire Rated Supply or Return Hoses

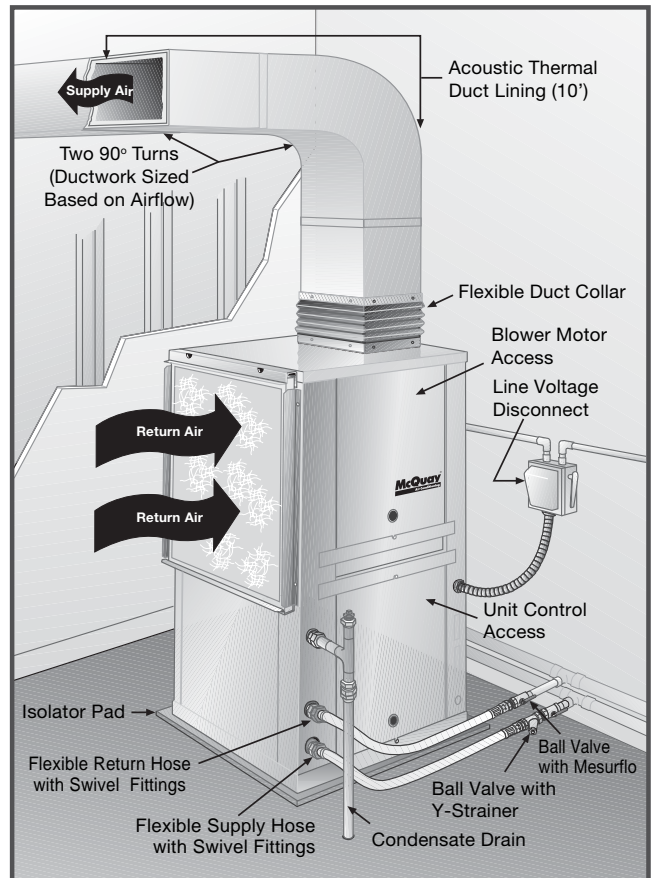


McQuay has available optional hose kit combinations to better facilitate system flow balancing. These flexible hoses reduce vibration between the unit and the rigid piping system. For more information on the types of hose kits review catalog 1196.

### Condensate Drain Piping

The correct factory provided condensate drain trap on the vertical unit is located inside the cabinet. Condensate removal piping must be pitched away from the unit not less than 1/4" per foot. A vent is required after the trap so that the condensate will drain away from the unit. The vent can also act as a clean out if the trap becomes clogged. To avoid having waste gases entering the building, the condensate drain should not be directly piped to a drain/waste/vent stack. See local codes for the correct application of condensate piping to drains.

### Typical Vertical Installation



# Applications – Unit Selection

Achieving optimal performance with water source heat pump systems requires both accurate system design and proper equipment selection. Use a building load program to determine the heating and cooling loads of each zone prior to making equipment selections. With this information, the McQuay SelectTools™ software selection program for Water Source Heat Pumps can be used to provide fast, accurate and complete selections of all McQuay water source heat pump products. SelectTools software is available by contacting your local McQuay Representative.

While we recommend that you use McQuay SelectTools software for all unit selections, manual selections can be accomplished using the same zone load information and the capacity tables available in this catalog.

## Boiler / Tower Application Manual Selections:

The following example illustrates a typical selection for a zone in a boiler/tower system for a commercial building.

A building load program determines that this zone needs 38,255 BTUH of total cooling, 31,832 BTUH of sensible cooling and 36,988 BTUH of total heating. The water temperatures for the boiler/tower system are 90°F for cooling and 70°F for heating. The return air temperature is 80°F dry bulb with 67°F wet bulb for cooling and 70°F for heating.

### Zone requirements:

Total Cooling Load	=	38,255 BTUH
Sensible Cooling Load	=	31,832 BTUH
Total Heating Load	=	36,988 BTUH
Air Flow Required	=	1510 CFM
Return Air Cooling	=	80°FDB/ 67°FWB
Return Air - Heating	=	70°FDB

Since a McQuay Enfinity Model CCH 036 produces approximately 36,000 BTUH of cooling, it is not sufficient for this zone and a model CCH 042 should be considered. Model CCH is chosen because it is specifically designed for a boiler/tower application. Typical water flow rates for boiler/tower applications are 2.0 to 2.5 GPM per ton and in this example no antifreeze is used.

### Selection:

Model ..... CCH 042 (Boiler / Tower model)

Total Cooling Capacity @ 90 EWT	=	40,816 BTUH
Sensible cooling capacity @ 90 EWT	=	32,704 BTUH
Total Heating Capacity @ 70 EWT	=	52,019 BTUH
		CFM = 1510 @ .5 ESP (Wet Coil)
Water Flow required to meet capacity	=	8 GPM
Water Pressure drop	=	6.9 (FT. H2O)

Final Selection ..... CCH 042

## Geothermal Applications:

The following example illustrates the same zone in a geothermal application.

The load requirements for the zone are the same as the above example – 38,255 BTUH of total cooling and 31,832 BTUH of sensible cooling and 36,988 BTUH of heating. Geothermal loop software programs are available to help determine the size of the loop field based on:

- Desired entering water temperatures for the system.
- Specific acreage available for the loop which produces specific min/max loop temps for the unit selection.

Entering water temperatures for geothermal systems can be as high as 90 to 100°F and as low as 30°F based on the geographical location of the building. Water flow rates are typically 2.5 to 3 GPM per ton and the use of antifreeze is required in most northern applications.

### Zone requirements:

Total Cooling Load	=	38,255 BTUH
Sensible Cooling Load	=	31,832 BTUH
Total Heating Load	=	36,988 BTUH
Air Flow Required	=	1510 CFM
Return Air Cooling	=	80 DB / 67 WB
Return Air - Heating	=	70 DB

A McQuay Enfinity Model CCW is chosen for this geothermal application. Model CCW offers insulated water piping for condensation considerations and a different freestat setting to allow entering water temperatures lower than 40°F (with antifreeze). Output capacities should be recalculated using the antifreeze reduction tables that are shown on page 49. The Model CCW 042 is first considered but may not meet the heating load because of the reduced entering water temperatures (35°F) and an antifreeze solution of 21 % propylene (see page 49).

### Selection:

Model ..... CCW 042 (Geothermal model)

Total Cooling Capacity @ 100 EWT	=	40,434 BTUH x .980 = 39,625
Sensible cooling capacity @ 100 EWT	=	32,164 BTUH x .980 = 31,520
Total Heating Capacity @ 35 EWT	=	38,335 BTUH x .975 = 37,377 CFM
		= 1510 @ .6 ESP (Dry Coil)
Water Flow required to meet capacity	=	10.8 GPM
Water Pressure drop	=	12.7x1.5= 14.61 (FT. H2O)

Final Selection ..... CCW 042

### Note:

In applications where the zone may be a corner office or have excessive glass area, the heating load could be greater than the heating output capacity of the CCW 042 model (say 41,985 BTUH). The choices are to upsize the unit to the next model available (048), or add an electric duct heater to supplement the output of the 042 unit.

# Enfinity Horizontal ISO Performance Data – Water Loop

Water Loop Performance Data per ISO Standard 13256-1.

UNIT SIZE	AIRFLOW		WATERFLOW		VOLTAGE	COOLING				HEATING		
	CFM	L/S	GPM	L/S		BTU/HR	WATTS	EER	COP	BTU/HR	WATTS	COP
007	230	109	1.4	0.09	115-1-60	6800	1991	12.7	3.7	9000	2635	4.7
					208/230-1-60							
					265-1-60							
009	300	142	2.2	0.14	115-1-60	8500	2489	12.2	3.6	11200	3279	4.3
					208/230-1-60							
					265-1-60							
012	400	189	3.1	0.20	115-1-60	11700	3426	12.3	3.6	15200	4451	4.2
					208/230-1-60							
					265-1-60							
019	630	297	5.2	0.33	208/230-1-60	19900	5827	14.4	4.2	25000	7320	4.9
					265-1-60							
					208/230-1-60							
024	800	378	5.9	0.37	208/230-1-60	23200	6793	13.9	4.1	29200	8550	4.8
					265-1-60							
					208/230-3-60							
					460-3-60							
030	1000	472	7.2	0.45	208/230-1-60	28800	8433	15.0	4.4	37400	10951	5.0
					265-1-60							
					208/230-3-60							
					460-3-60							
036	1200	566	8.8	0.56	208/230-1-60	34600	10131	13.9	4.1	44700	13089	4.6
					208/230-3-60							
					460-3-60							
042	1400	661	10.7	0.68	208/230-1-60	42900	12562	14.9	4.4	52500	15373	4.9
					208/230-3-60							
					460-3-60							
					575-3-60							
048	1600	755	11.6	0.73	208/230-1-60	46400	13586	14.2	4.2	58700	17188	4.6
					208/230-3-60							
					460-3-60							
					575-3-60							
060	2000	944	14.8	0.93	208/230-1-60	60100	17598	14.0	4.1	75000	21961	4.7
					208/230-3-60							
					460-3-60							
					575-3-60							

**Notes:**

EER = Energy Efficiency Ratio      COP = Coefficient of Performance      L/s = Liters per second

Cooling capacity is based on 80.6°F db, 66.2°F wb (27/19°C) entering air temperature and 86°F (30°C) entering water temperature.  
 Heating capacity is based on 68°F (20°C) entering air temperature and 68°F (20°C) entering water temperature.

# Enfinity Horizontal ISO Performance Data – Ground Loop

Ground Loop Performance Data per ISO Standard 13256-1.

UNIT SIZE	AIRFLOW		WATERFLOW		VOLTAGE	COOLING				HEATING		
	CFM	L/S	GPM	L/S		BTU/HR	WATTS	EER	COP	BTU/HR	WATTS	COP
007	230	109	1.4	0.09	115-1-60	7200	2108	14.3	4.2	5700	1669	3.4
					208/230-1-60							
					265-1-60							
009	300	142	2.2	0.14	115-1-60	9000	2635	14.2	4.2	7500	2196	3.2
					208/230-1-60							
					265-1-60							
012	400	189	3.1	0.20	115-1-60	12500	3660	14.5	4.2	9800	2870	3.2
					208/230-1-60							
					265-1-60							
019	630	297	5.2	0.33	208/230-1-60	21600	6325	17.0	5.0	14700	4304	3.6
					265-1-60							
024	800	378	5.9	0.37	208/230-1-60	25100	7350	16.6	4.8	18300	5358	3.7
					265-1-60							
					208/230-3-60							
					460-3-60							
030	1000	472	7.2	0.45	208/230-1-60	30200	8843	17.4	5.1	24000	7027	3.7
					265-1-60							
					208/230-3-60							
					460-3-60							
036	1200	566	8.8	0.56	208/230-1-60	36200	10600	16.0	4.7	29600	8667	3.4
					208/230-3-60							
					460-3-60							
042	1400	661	10.7	0.68	208/230-1-60	43700	12796	17.1	5.0	35000	10248	3.7
					208/230-3-60							
					460-3-60							
					575-3-60							
048	1600	755	11.6	0.73	208/230-1-60	48800	14289	16.0	4.7	38100	11156	3.5
					208/230-3-60							
					460-3-60							
					575-3-60							
060	2000	944	14.8	0.93	208/230-1-60	62400	18271	16.1	4.7	50100	14670	3.5
					208/230-3-60							
					460-3-60							
					575-3-60							

**Notes:**

EER = Energy Efficiency Ratio      COP = Coefficient of Performance      L/S = Liters per second

Cooling capacity is based on 80.6°F db, 66.2°F wb (27/19°C) entering air temperature and 77°F (25°C) entering water temperature.  
 Heating capacity is based on 68°F (20°C) entering air temperature and 32°F (0°C) entering water temperature.

# Enfinity Horizontal ISO Performance Data – Ground Source

Ground Source Performance Data per ISO Standard 13256-1.

UNIT SIZE	AIRFLOW		WATERFLOW		VOLTAGE	COOLING				HEATING		
	CFM	L/S	GPM	L/S		BTU/HR	WATTS	EER	COP	BTU/HR	WATTS	COP
007	230	109	1.4	0.09	115-1-60	7800	2284	20.2	5.9	6900	2020	4.0
					208/230-1-60							
					265-1-60							
009	300	142	2.2	0.14	115-1-60	9700	2840	18.6	5.5	9400	2752	3.9
					208/230-1-60							
					265-1-60							
012	400	189	3.1	0.20	115-1-60	13700	4012	19.1	5.6	12600	3689	3.8
					208/230-1-60							
					265-1-60							
019	630	297	5.2	0.33	208/230-1-60	24600	7203	23.3	6.8	19900	5827	4.3
					265-1-60							
024	800	378	5.9	0.37	208/230-1-60	28500	8345	22.5	6.6	24000	7027	4.3
					265-1-60							
					208/230-3-60							
					460-3-60							
030	1000	472	7.2	0.45	208/230-1-60	32800	9604	23.1	6.8	30600	8960	4.3
					265-1-60							
					208/230-3-60							
					460-3-60							
036	1200	566	8.8	0.56	208/230-1-60	39800	11654	21.2	6.2	37600	11010	4.1
					208/230-3-60							
					460-3-60							
042	1400	661	10.7	0.68	208/230-1-60	47900	14026	23.0	6.3	43600	12767	4.4
					208/230-3-60							
					460-3-60							
					575-3-60							
048	1600	755	11.6	0.73	208/230-1-60	52400	15343	21.0	6.2	48400	14172	4.1
					208/230-3-60							
					460-3-60							
					575-3-60							
060	2000	944	14.8	0.93	208/230-1-60	67100	19648	20.6	6.0	61000	17861	4.1
					208/230-3-60							
					460-3-60							
					575-3-60							

**Notes:**

EER = Energy Efficiency Ratio      COP = Coefficient of Performance      L/S = Liters per second

Cooling capacity is based on 80.6°F db, 66.2°F wb (27/19°C) entering air temperature and 59°F (15°C) entering water temperature.  
 Heating capacity is based on 68°F (20°C) entering air temperature and 50°F (10°C) entering water temperature.

# Cooling Capacity Data – Horizontal Unit Size 007

EWT	GPM	WPD	System Cooling						ISO System Cooling			
			EA	LWT	TOT	SEN	kW	EER	TOT	kW	EER	THR
30	1.0	1.5	75/63	48.0	7588	5885	0.250	30.4	7711	0.215	35.9	8455
			80/67	49.3	8199	6096	0.249	32.9	8322	0.214	38.9	9073
			85/71	50.7	8842	6289	0.247	35.8	8965	0.212	42.3	9720
	1.4	3.0	75/63	42.8	7666	5922	0.211	36.3	7789	0.178	43.8	8408
			80/67	43.8	8301	6140	0.207	40.1	8424	0.174	48.5	9042
			85/71	44.8	8966	6339	0.202	44.4	9089	0.169	53.9	9701
	1.9	5.5	75/63	39.4	7715	5946	0.183	42.2	7838	0.154	51.0	8369
			80/67	40.1	8364	6167	0.177	47.3	8487	0.148	57.5	9016
			85/71	40.9	9047	6371	0.171	52.9	9170	0.142	64.8	9685
40	1.0	1.5	75/63	58.2	7417	5805	0.324	22.9	7540	0.289	26.1	8515
			80/67	59.4	7995	6007	0.322	24.8	8118	0.287	28.3	9097
			85/71	60.8	8606	6196	0.319	27.0	8729	0.284	30.7	9712
	1.4	3.0	75/63	53.0	7506	5847	0.289	26.0	7629	0.256	29.8	8497
			80/67	53.9	8106	6054	0.284	28.5	8229	0.251	32.8	9092
			85/71	54.8	8741	6248	0.279	31.3	8864	0.246	36.1	9724
	1.9	5.5	75/63	49.5	7562	5873	0.265	28.5	7685	0.236	32.6	8470
			80/67	50.2	8174	6085	0.259	31.6	8297	0.230	36.1	9078
			85/71	50.9	8827	6283	0.252	35.0	8950	0.223	40.2	9726
50	1.0	1.5	75/63	68.3	7220	5712	0.392	18.4	7343	0.357	20.6	8533
			80/67	69.5	7771	5911	0.389	20.0	7894	0.354	22.3	9081
			85/71	70.7	8353	6096	0.386	21.6	8475	0.351	24.2	9669
	1.4	3.0	75/63	63.0	7319	5758	0.360	20.3	7442	0.327	22.8	8527
			80/67	63.9	7889	5961	0.355	22.2	8012	0.322	24.9	9094
			85/71	64.8	8494	6151	0.350	24.3	8617	0.317	27.2	9700
	1.9	5.5	75/63	59.6	7377	5787	0.339	21.8	7500	0.310	24.2	8521
			80/67	60.2	7962	5994	0.332	24.0	8085	0.303	26.7	9097
			85/71	60.9	8584	6187	0.326	26.3	8707	0.297	29.4	9715
60	1.0	1.5	75/63	78.3	7002	5611	0.453	15.5	7125	0.418	17.0	8505
			80/67	79.4	7528	5807	0.452	16.7	7651	0.417	18.4	9033
			85/71	80.6	8080	5989	0.450	18.0	8203	0.415	19.8	9595
	1.4	3.0	75/63	73.1	7108	5660	0.425	16.7	7231	0.392	18.5	8521
			80/67	73.9	7654	5860	0.421	18.2	7777	0.388	20.1	9062
			85/71	74.8	8229	6047	0.416	19.8	8352	0.383	21.8	9641
	1.9	5.5	75/63	69.6	7174	5691	0.405	17.7	7297	0.376	19.4	8527
			80/67	70.2	7732	5894	0.400	19.3	7855	0.371	21.2	9077
			85/71	70.9	8323	6084	0.393	21.2	8446	0.364	23.2	9655
70	1.0	1.5	75/63	88.2	6764	5502	0.512	13.2	6887	0.477	14.4	8450
			80/67	89.3	7266	5696	0.511	14.2	7389	0.476	15.5	8957
			85/71	90.4	7791	5877	0.511	15.2	7914	0.476	16.6	9495
	1.4	3.0	75/63	83.0	6878	5554	0.485	14.2	7001	0.452	15.5	8488
			80/67	83.8	7398	5752	0.482	15.3	7521	0.449	16.8	8997
			85/71	84.7	7947	5937	0.479	16.6	8070	0.446	18.1	9542
	1.9	5.5	75/63	79.6	6949	5587	0.467	14.9	7072	0.438	16.2	8491
			80/67	80.2	7481	5787	0.463	16.2	7604	0.434	17.5	9021
			85/71	80.8	8045	5975	0.458	17.6	8168	0.429	19.1	9578
80	1.0	1.5	75/63	98.0	6508	5384	0.569	11.4	6631	0.534	12.4	8367
			80/67	99.1	6982	5577	0.570	12.2	7105	0.535	13.3	8860
			85/71	100.2	7485	5759	0.571	13.1	7608	0.536	14.2	9368
	1.4	3.0	75/63	92.9	6628	5439	0.543	12.2	6751	0.510	13.2	8407
			80/67	93.7	7123	5636	0.542	13.1	7246	0.509	14.2	8910
			85/71	94.5	7645	5820	0.540	14.2	7768	0.507	15.3	9435
	1.9	5.5	75/63	89.6	6704	5474	0.526	12.7	6827	0.497	13.7	8431
			80/67	90.1	7211	5672	0.523	13.8	7334	0.494	14.9	8941
			85/71	90.7	7748	5860	0.520	14.9	7871	0.491	16.0	9474
85	1.0	1.5	75/63	102.9	6373	5323	0.597	10.7	6496	0.562	11.6	8317
			80/67	104.0	6836	5515	0.599	11.4	6959	0.564	12.3	8803
			85/71	105.1	7327	5699	0.601	12.2	7450	0.566	13.2	9301
	1.4	3.0	75/63	97.9	6496	5379	0.571	11.4	6619	0.538	12.3	8363
			80/67	98.6	6979	5575	0.571	12.2	7102	0.538	13.2	8859
			85/71	99.4	7489	5760	0.570	13.1	7612	0.537	14.2	9367
	1.9	5.5	75/63	94.5	6573	5414	0.555	11.8	6696	0.526	12.7	8389
			80/67	95.1	7067	5611	0.553	12.8	7190	0.524	13.7	8892
			85/71	95.7	7593	5801	0.550	13.8	7716	0.521	14.8	9417
90	1.0	1.5	75/63	107.8	6234	5260	0.625	10.0	6357	0.590	10.8	8263
			80/67	108.9	6687	5454	0.629	10.6	6809	0.594	11.5	8742
			85/71	109.9	7164	5637	0.631	11.4	7287	0.596	12.2	9233
	1.4	3.0	75/63	102.8	6359	5316	0.600	10.6	6482	0.567	11.4	8312
			80/67	103.6	6831	5513	0.601	11.4	6954	0.568	12.3	8801
			85/71	104.3	7328	5699	0.601	12.2	7451	0.568	13.1	9305
	1.9	5.5	75/63	99.5	6439	5353	0.583	11.0	6562	0.554	11.9	8342
			80/67	100.0	6922	5551	0.583	11.9	7045	0.554	12.7	8837
			85/71	100.6	7433	5740	0.581	12.8	7556	0.552	13.7	9351
100	1.0	1.5	75/63	117.6	5934	5124	0.683	8.7	6057	0.648	9.3	8145
			80/67	118.6	6369	5321	0.689	9.2	6492	0.654	9.9	8615
			85/71	119.7	6826	5509	0.694	9.8	6949	0.659	10.5	9097
	1.4	3.0	75/63	112.7	6066	5184	0.657	9.2	6189	0.624	9.9	8199
			80/67	113.4	6518	5383	0.661	9.9	6641	0.628	10.6	8675
			85/71	114.2	6994	5572	0.663	10.5	7117	0.630	11.3	9164
	1.9	5.5	75/63	109.4	6149	5221	0.641	9.6	6272	0.612	10.3	8232
			80/67	109.9	6617	5424	0.643	10.3	6740	0.614	11.0	8716
			85/71	110.5	7102	5613	0.643	11.0	7225	0.614	11.8	9210
110	1.0	1.5	75/63	127.4	5620	4984	0.744	7.6	5743	0.709	8.1	8019
			80/67	128.4	6035	5184	0.753	8.0	6158	0.718	8.6	8474
			85/71	129.4	6470	5375	0.761	8.5	6593	0.726	9.1	8948
	1.4	3.0	75/63	122.5	5757	5045	0.717	8.0	5880	0.684	8.6	8074
			80/67	123.2	6190	5248	0.723	8.6	6313	0.690	9.2	8531
			85/71	124.0	6643	5440	0.728	9.1	6766	0.695	9.7	9014
	1.9	5.5	75/63	119.2	5844	5084	0.701	8.3	5967	0.672	8.9	8110
			80/67	119.8	6290	5289	0.705	8.9	6413	0.676	9.5	8574
			85/71	120.3	6753	5481	0.708	9.5	6876	0.679	10.1	9061

# Heating Capacity Data - Horizontal Unit Size 007

EWT	GPM	WPD	System Heating					ISO System Heating			
			EA	LWT	TOT	kW	COP	TOT	kW	COP	THA
20	1.0	1.5	60	12.8	4725	0.454	3.05	4602	0.419	3.22	3455
			70	13.0	4721	0.487	2.84	4598	0.452	2.98	3339
			80	13.3	4662	0.516	2.65	4539	0.481	2.76	3189
	1.4	3.0	60	14.6	4873	0.458	3.12	4750	0.425	3.28	3591
			70	14.8	4858	0.492	2.89	4735	0.459	3.02	3467
			80	15.1	4795	0.522	2.69	4672	0.489	2.80	3303
	1.9	5.5	60	15.9	4980	0.461	3.16	4857	0.432	3.30	3689
			70	16.1	4952	0.495	2.93	4829	0.466	3.04	3553
			80	16.3	4882	0.526	2.72	4759	0.497	2.81	3382
30	1.0	1.5	60	21.3	5446	0.473	3.37	5323	0.438	3.56	4127
			70	21.6	5415	0.510	3.11	5293	0.475	3.26	3978
			80	22.0	5353	0.545	2.88	5230	0.510	3.00	3799
	1.4	3.0	60	23.5	5629	0.478	3.45	5506	0.445	3.63	4302
			70	23.8	5588	0.515	3.18	5465	0.482	3.32	4138
			80	24.1	5513	0.551	2.93	5391	0.518	3.05	3944
	1.9	5.5	60	25.1	5758	0.481	3.50	5635	0.452	3.65	4429
			70	25.3	5711	0.519	3.22	5588	0.490	3.34	4254
			80	25.5	5621	0.555	2.97	5498	0.526	3.06	4048
40	1.0	1.5	60	29.8	6211	0.490	3.71	6088	0.455	3.92	4861
			70	30.1	6162	0.531	3.40	6039	0.496	3.57	4674
			80	30.6	6084	0.571	3.12	5961	0.536	3.26	4464
	1.4	3.0	60	32.4	6442	0.495	3.81	6319	0.462	4.01	5075
			70	32.7	6373	0.537	3.47	6250	0.504	3.63	4874
			80	33.0	6282	0.577	3.19	6159	0.544	3.32	4647
	1.9	5.5	60	34.2	6604	0.498	3.88	6481	0.469	4.05	5231
			70	34.4	6524	0.541	3.53	6401	0.512	3.66	5016
			80	34.7	6423	0.582	3.23	6300	0.553	3.34	4776
50	1.0	1.5	60	38.1	7032	0.507	4.06	6910	0.472	4.29	5643
			70	38.5	6959	0.551	3.70	6836	0.516	3.88	5425
			80	39.0	6862	0.596	3.37	6739	0.561	3.52	5184
	1.4	3.0	60	41.1	7311	0.512	4.18	7188	0.479	4.40	5908
			70	41.4	7214	0.557	3.79	7091	0.524	3.97	5668
			80	41.8	7102	0.603	3.45	6979	0.570	3.59	5405
	1.9	5.5	60	43.2	7509	0.515	4.27	7386	0.486	4.45	6100
			70	43.5	7403	0.562	3.86	7280	0.533	4.00	5843
			80	43.8	7274	0.608	3.50	7151	0.579	3.62	5564
60	1.0	1.5	60	46.3	7898	0.522	4.43	7775	0.487	4.68	6478
			70	46.8	7799	0.571	4.00	7676	0.536	4.19	6219
			80	47.4	7681	0.620	3.63	7558	0.585	3.78	5945
	1.4	3.0	60	49.7	8227	0.528	4.56	8104	0.495	4.80	6798
			70	50.1	8108	0.577	4.11	7985	0.544	4.30	6518
			80	50.6	7974	0.628	3.72	7851	0.595	3.87	6220
	1.9	5.5	60	52.2	8470	0.532	4.66	8347	0.503	4.86	7026
			70	52.5	8333	0.582	4.19	8210	0.553	4.35	6726
			80	52.8	8178	0.634	3.78	8055	0.605	3.90	6408
70	1.0	1.5	60	54.4	8805	0.538	4.79	8682	0.503	5.05	7353
			70	55.0	8693	0.590	4.31	8570	0.555	4.52	7057
			80	55.7	8551	0.644	3.89	8429	0.609	4.05	6755
	1.4	3.0	60	58.3	9197	0.544	4.95	9074	0.511	5.20	7733
			70	58.8	9052	0.598	4.43	8929	0.565	4.63	7411
			80	59.3	8895	0.653	3.99	8773	0.620	4.15	7074
	1.9	5.5	60	61.0	9477	0.549	5.05	9354	0.520	5.27	8011
			70	61.4	9310	0.603	4.52	9187	0.574	4.69	7667
			80	61.8	9137	0.660	4.05	9014	0.631	4.19	7302
80	1.0	1.5	60	62.4	9750	0.554	5.15	9627	0.519	5.43	8265
			70	63.1	9604	0.610	4.61	9481	0.575	4.83	7937
			80	63.8	9458	0.669	4.14	9335	0.634	4.31	7594
	1.4	3.0	60	66.7	10215	0.562	5.32	10092	0.529	5.59	8717
			70	67.3	10040	0.619	4.75	9917	0.586	4.96	8350
			80	67.9	9858	0.680	4.24	9735	0.647	4.41	7972
	1.9	5.5	60	69.9	10543	0.567	5.44	10420	0.538	5.68	9034
			70	70.3	10345	0.626	4.84	10222	0.597	5.02	8645
			80	70.8	10145	0.688	4.32	10022	0.659	4.46	8244
85	1.0	1.5	60	66.4	10234	0.562	5.33	10111	0.527	5.62	8734
			70	67.1	10081	0.620	4.76	9958	0.585	4.99	8389
			80	67.9	9920	0.681	4.27	9797	0.646	4.44	8029
	1.4	3.0	60	71.0	10742	0.571	5.51	10619	0.538	5.78	9217
			70	71.6	10549	0.630	4.90	10426	0.597	5.12	8836
			80	72.2	10357	0.693	4.38	10234	0.660	4.54	8435
	1.9	5.5	60	74.3	11089	0.577	5.63	10966	0.548	5.86	9562
			70	74.7	10879	0.638	4.99	10756	0.609	5.18	9151
			80	75.2	10665	0.702	4.45	10542	0.673	4.59	8727
90	1.0	1.5	60	70.4	10739	0.571	5.51	10616	0.536	5.80	9211
			70	71.1	10563	0.631	4.90	10440	0.596	5.13	8848
			80	71.9	10397	0.695	4.38	10274	0.660	4.56	8471
	1.4	3.0	60	75.2	11271	0.580	5.69	11148	0.547	5.97	9734
			70	75.8	11063	0.642	5.05	10940	0.609	5.26	9327
			80	76.4	10865	0.708	4.49	10742	0.675	4.66	8910
	1.9	5.5	60	78.7	11651	0.587	5.81	11528	0.558	6.05	10100
			70	79.2	11419	0.650	5.14	11296	0.621	5.33	9665
			80	79.7	11197	0.717	4.57	11074	0.688	4.72	9219

# Cooling Capacity Data – Horizontal Unit Size 009

EWT	GPM	WPD	System Cooling						ISO System Cooling			
			EA	LWT	TOT	SEN	kW	EER	TOT	kW	EER	THR
30	1.3	2.6	75/63	48.1	9215	7503	0.415	22.2	9435	0.353	26.8	10572
			80/67	49.4	9918	7755	0.421	23.6	10139	0.359	28.3	11312
			85/71	50.7	10671	7993	0.422	25.3	10891	0.360	30.3	12087
	1.8	4.9	75/63	43.0	9282	7537	0.372	25.0	9503	0.313	30.4	10510
			80/67	43.9	10002	7794	0.378	26.5	10222	0.319	32.0	11267
			85/71	44.9	10774	8036	0.379	28.4	10994	0.320	34.4	12059
	2.4	8.8	75/63	39.7	9320	7555	0.344	27.1	9541	0.293	32.6	10469
			80/67	40.4	10050	7815	0.349	28.8	10270	0.298	34.5	11228
			85/71	41.2	10834	8061	0.349	31.0	11054	0.298	37.1	12029
40	1.3	2.6	75/63	58.3	9048	7422	0.495	18.3	9269	0.433	21.4	10647
			80/67	59.5	9729	7670	0.497	19.6	9950	0.435	22.9	11353
			85/71	60.8	10457	7904	0.494	21.2	10678	0.432	24.7	12086
	1.8	4.9	75/63	53.2	9132	7463	0.458	19.9	9353	0.399	23.4	10619
			80/67	54.1	9831	7716	0.459	21.4	10052	0.400	25.1	11343
			85/71	55.0	10580	7955	0.456	23.2	10800	0.397	27.2	12094
	2.4	8.8	75/63	49.9	9182	7488	0.433	21.2	9403	0.382	24.6	10595
			80/67	50.5	9891	7744	0.434	22.8	10111	0.383	26.4	11327
			85/71	51.2	10651	7986	0.430	24.8	10872	0.379	28.7	12083
50	1.3	2.6	75/63	68.4	8847	7323	0.566	15.6	9068	0.504	18.0	10658
			80/67	69.5	9501	7567	0.565	16.8	9721	0.503	19.3	11337
			85/71	70.7	10204	7800	0.560	18.2	10425	0.498	21.0	12028
	1.8	4.9	75/63	63.3	8943	7370	0.533	16.8	9164	0.474	19.3	10660
			80/67	64.1	9619	7621	0.532	18.1	9840	0.473	20.8	11344
			85/71	65.0	10343	7857	0.526	19.7	10563	0.467	22.6	12069
	2.4	8.8	75/63	59.9	9003	7400	0.512	17.6	9223	0.461	20.0	10656
			80/67	60.6	9691	7653	0.509	19.0	9911	0.458	21.7	11353
			85/71	61.3	10427	7893	0.503	20.7	10647	0.452	23.6	12082
60	1.3	2.6	75/63	78.3	8604	7206	0.630	13.7	8825	0.568	15.5	10613
			80/67	79.4	9238	7451	0.628	14.7	9459	0.566	16.7	11249
			85/71	80.6	9915	7683	0.622	15.9	10136	0.560	18.1	11922
	1.8	4.9	75/63	73.3	8719	7261	0.601	14.5	8939	0.542	16.5	10640
			80/67	74.1	9368	7508	0.598	15.7	9589	0.539	17.8	11289
			85/71	74.9	10068	7746	0.591	17.0	10289	0.532	19.3	11983
	2.4	8.8	75/63	70.0	8789	7296	0.582	15.1	9010	0.531	17.0	10652
			80/67	70.6	9452	7546	0.578	16.4	9672	0.527	18.4	11318
			85/71	71.2	10163	7784	0.569	17.9	10384	0.518	20.1	12016
70	1.3	2.6	75/63	88.2	8338	7078	0.692	12.0	8559	0.630	13.6	10524
			80/67	89.3	8945	7321	0.689	13.0	9166	0.627	14.6	11138
			85/71	90.4	9589	7551	0.684	14.0	9809	0.622	15.8	11780
	1.8	4.9	75/63	83.2	8465	7139	0.665	12.7	8685	0.606	14.3	10569
			80/67	84.0	9084	7382	0.661	13.7	9305	0.602	15.5	11197
			85/71	84.8	9757	7618	0.653	14.9	9977	0.594	16.8	11856
	2.4	8.8	75/63	79.9	8537	7174	0.647	13.2	8758	0.596	14.7	10595
			80/67	80.5	9176	7423	0.642	14.3	9397	0.591	15.9	11231
			85/71	81.1	9862	7661	0.633	15.6	10083	0.582	17.3	11903
80	1.3	2.6	75/63	98.0	8033	6932	0.752	10.7	8253	0.690	12.0	10399
			80/67	99.0	8616	7177	0.751	11.5	8836	0.689	12.8	10989
			85/71	100.1	9241	7411	0.746	12.4	9462	0.684	13.8	11610
	1.8	4.9	75/63	93.1	8169	6998	0.726	11.3	8389	0.667	12.6	10457
			80/67	93.8	8772	7245	0.722	12.1	8992	0.663	13.6	11061
			85/71	94.6	9415	7481	0.715	13.2	9636	0.656	14.7	11697
	2.4	8.8	75/63	89.8	8255	7039	0.709	11.6	8476	0.658	12.9	10492
			80/67	90.4	8869	7287	0.704	12.6	9089	0.653	13.9	11105
			85/71	91.0	9526	7525	0.696	13.7	9747	0.645	15.1	11750
85	1.3	2.6	75/63	102.9	7869	6855	0.782	10.1	8090	0.720	11.2	10327
			80/67	103.9	8439	7100	0.782	10.8	8660	0.720	12.0	10906
			85/71	105.0	9044	7333	0.779	11.6	9265	0.717	12.9	11513
	1.8	4.9	75/63	98.0	8010	6921	0.756	10.6	8231	0.697	11.8	10389
			80/67	98.7	8600	7170	0.754	11.4	8821	0.695	12.7	10982
			85/71	99.5	9228	7406	0.748	12.3	9449	0.689	13.7	11607
	2.4	8.8	75/63	94.8	8099	6964	0.739	11.0	8320	0.688	12.1	10428
			80/67	95.4	8701	7213	0.735	11.8	8922	0.684	13.0	11029
			85/71	95.9	9344	7453	0.728	12.8	9564	0.677	14.1	11664
90	1.3	2.6	75/63	107.8	7699	6774	0.814	9.5	7919	0.752	10.5	10247
			80/67	108.8	8255	7020	0.815	10.1	8476	0.753	11.3	10816
			85/71	109.8	8844	7254	0.813	10.9	9065	0.751	12.1	11416
	1.8	4.9	75/63	102.9	7844	6843	0.787	10.0	8064	0.728	11.1	10317
			80/67	103.7	8421	7092	0.786	10.7	8641	0.727	11.9	10897
			85/71	104.4	9034	7329	0.781	11.6	9255	0.722	12.8	11511
	2.4	8.8	75/63	99.7	7936	6886	0.770	10.3	8156	0.719	11.3	10356
			80/67	100.3	8525	7137	0.767	11.1	8745	0.716	12.2	10947
			85/71	100.9	9153	7376	0.760	12.0	9373	0.709	13.2	11571
100	1.3	2.6	75/63	117.5	7338	6605	0.881	8.3	7558	0.819	9.2	10081
			80/67	118.5	7864	6852	0.885	8.9	8085	0.823	9.8	10632
			85/71	119.5	8422	7088	0.887	9.5	8642	0.825	10.5	11213
	1.8	4.9	75/63	112.7	7489	6675	0.852	8.8	7709	0.793	9.7	10152
			80/67	113.4	8040	6927	0.854	9.4	8260	0.795	10.4	10713
			85/71	114.2	8626	7167	0.852	10.1	8846	0.793	11.2	11311
	2.4	8.8	75/63	109.6	7586	6721	0.835	9.1	7806	0.784	10.0	10192
			80/67	110.1	8148	6974	0.834	9.8	8369	0.783	10.7	10768
			85/71	110.7	8752	7217	0.830	10.5	8973	0.779	11.5	11374
110	1.3	2.6	75/63	127.3	6947	6423	0.955	7.3	7167	0.893	8.0	9910
			80/67	128.2	7444	6671	0.964	7.7	7664	0.902	8.5	10446
			85/71	129.2	7968	6911	0.971	8.2	8189	0.909	9.0	10994
	1.8	4.9	75/63	122.6	7108	6497	0.924	7.7	7328	0.865	8.5	9980
			80/67	123.2	7632	6752	0.929	8.2	7852	0.870	9.0	10528
			85/71	124.0	8173	6990	0.932	8.8	8393	0.873	9.6	11105
	2.4	8.8	75/63	119.5	7208	6544	0.905	8.0	7428	0.854	8.7	10024
			80/67	120.0	7741	6799	0.908	8.5	7961	0.857	9.3	10584
			85/71	120.5	8309	7043	0.908	9.2	8530	0.857	10.0	11155



# Heating Capacity Data – Horizontal Unit Size 009

EWT	GPM	WPD	System Heating					ISO System Heating			
			EA	LWT	TOT	kW	COP	TOT	kW	COP	THA
20	1.3	2.6	60	12.7	6120	0.587	3.05	5900	0.525	3.29	4496
			70	13.0	6126	0.645	2.78	5906	0.583	2.97	4314
			80	13.3	6080	0.693	2.57	5860	0.631	2.72	4116
	1.8	4.9	60	14.5	6304	0.597	3.09	6083	0.538	3.31	4653
			70	14.7	6299	0.654	2.82	6078	0.595	2.99	4462
			80	15.0	6242	0.701	2.61	6021	0.642	2.75	4254
	2.4	8.8	60	15.8	6434	0.604	3.12	6214	0.553	3.29	4763
			70	16.0	6424	0.660	2.85	6204	0.609	2.98	4565
			80	16.2	6359	0.708	2.63	6138	0.657	2.74	4349
30	1.3	2.6	60	21.3	7052	0.635	3.25	6832	0.573	3.49	5294
			70	21.7	7029	0.690	2.98	6808	0.628	3.18	5096
			80	22.0	6966	0.739	2.76	6746	0.677	2.92	4873
	1.8	4.9	60	23.5	7278	0.646	3.30	7057	0.587	3.52	5488
			70	23.8	7235	0.700	3.03	7014	0.641	3.20	5275
			80	24.0	7160	0.748	2.80	6940	0.689	2.95	5041
	2.4	8.8	60	25.0	7433	0.653	3.33	7212	0.602	3.51	5625
			70	25.2	7380	0.706	3.06	7159	0.655	3.20	5403
			80	25.4	7295	0.755	2.83	7075	0.704	2.94	5159
40	1.3	2.6	60	29.9	8029	0.677	3.47	7808	0.615	3.72	6157
			70	30.3	7971	0.731	3.19	7750	0.669	3.39	5930
			80	30.7	7889	0.782	2.95	7669	0.720	3.12	5681
	1.8	4.9	60	32.4	8294	0.687	3.54	8074	0.628	3.76	6401
			70	32.7	8223	0.740	3.25	8002	0.681	3.44	6159
			80	33.0	8121	0.792	3.00	7900	0.733	3.16	5886
	2.4	8.8	60	34.1	8484	0.693	3.58	8264	0.642	3.77	6569
			70	34.4	8394	0.747	3.29	8174	0.696	3.44	6312
			80	34.6	8280	0.798	3.04	8060	0.747	3.16	6030
50	1.3	2.6	60	38.3	9060	0.711	3.73	8840	0.649	3.99	7088
			70	38.7	8961	0.766	3.43	8740	0.704	3.64	6833
			80	39.2	8857	0.821	3.16	8636	0.759	3.33	6545
	1.8	4.9	60	41.2	9365	0.720	3.81	9145	0.661	4.05	7390
			70	41.5	9262	0.775	3.50	9042	0.716	3.70	7107
			80	41.9	9132	0.831	3.22	8911	0.772	3.38	6797
	2.4	8.8	60	43.2	9589	0.725	3.87	9368	0.674	4.07	7603
			70	43.5	9466	0.781	3.55	9246	0.730	3.71	7303
			80	43.8	9322	0.837	3.26	9102	0.786	3.39	6970
60	1.3	2.6	60	46.6	10121	0.737	4.02	9900	0.675	4.30	8101
			70	47.1	10001	0.795	3.68	9781	0.733	3.91	7798
			80	47.7	9873	0.855	3.38	9652	0.793	3.57	7467
	1.8	4.9	60	49.9	10498	0.744	4.13	10278	0.685	4.39	8469
			70	50.3	10354	0.802	3.78	10134	0.743	3.99	8132
			80	50.7	10189	0.865	3.45	9969	0.806	3.62	7770
	2.4	8.8	60	52.2	10755	0.748	4.21	10534	0.697	4.43	8721
			70	52.5	10598	0.808	3.84	10378	0.757	4.02	8368
			80	52.8	10420	0.871	3.50	10199	0.820	3.64	7985
70	1.3	2.6	60	54.8	11240	0.754	4.36	11019	0.692	4.67	9180
			70	55.4	11084	0.816	3.98	10864	0.754	4.22	8832
			80	56.0	10923	0.885	3.61	10703	0.823	3.81	8448
	1.8	4.9	60	58.5	11678	0.759	4.51	11457	0.700	4.79	9623
			70	59.0	11509	0.823	4.09	11289	0.764	4.33	9233
			80	59.5	11300	0.894	3.70	11079	0.835	3.89	8819
	2.4	8.8	60	61.1	11990	0.761	4.61	11769	0.710	4.86	9939
			70	61.5	11785	0.827	4.17	11564	0.776	4.37	9518
			80	61.9	11568	0.900	3.76	11348	0.849	3.92	9070
80	1.3	2.6	60	62.8	12405	0.763	4.76	12185	0.701	5.09	10342
			70	63.5	12218	0.832	4.30	11997	0.770	4.57	9938
			80	64.3	12021	0.909	3.87	11800	0.847	4.08	9493
	1.8	4.9	60	67.0	12908	0.764	4.95	12687	0.705	5.27	10861
			70	67.5	12687	0.836	4.44	12467	0.777	4.70	10412
			80	68.1	12471	0.918	3.98	12250	0.859	4.18	9934
	2.4	8.8	60	69.9	13276	0.765	5.08	13056	0.714	5.36	11238
			70	70.3	13025	0.838	4.55	12804	0.787	4.77	10756
			80	70.8	12783	0.923	4.06	12562	0.872	4.22	10237
85	1.3	2.6	60	66.8	13005	0.765	4.98	12784	0.703	5.33	10946
			70	67.6	12800	0.837	4.48	12580	0.775	4.76	10513
			80	68.3	12585	0.919	4.01	12364	0.857	4.23	10045
	1.8	4.9	60	71.2	13539	0.764	5.19	13319	0.705	5.53	11508
			70	71.8	13307	0.840	4.64	13086	0.781	4.91	11027
			80	72.4	13067	0.927	4.13	12846	0.868	4.33	10508
	2.4	8.8	60	74.3	13936	0.763	5.35	13715	0.712	5.64	11916
			70	74.7	13672	0.842	4.75	13452	0.791	4.98	11403
			80	75.2	13399	0.932	4.21	13178	0.881	4.38	10841
90	1.3	2.6	60	70.8	13606	0.764	5.21	13385	0.702	5.59	11566
			70	71.6	13393	0.841	4.66	13172	0.779	4.95	11104
			80	72.4	13173	0.929	4.15	12952	0.867	4.38	10602
	1.8	4.9	60	75.4	14198	0.762	5.46	13977	0.703	5.82	12182
			70	76.0	13932	0.842	4.84	13711	0.783	5.13	11658
			80	76.7	13681	0.936	4.28	13461	0.877	4.49	11104
	2.4	8.8	60	78.6	14606	0.759	5.63	14386	0.708	5.95	12617
			70	79.1	14326	0.843	4.98	14105	0.792	5.22	12059
			80	79.7	14053	0.941	4.37	13832	0.890	4.55	11458

# Cooling Capacity Data – Horizontal Unit Size 012

EWT	GPM	WPD	System Cooling					ISO System Cooling				
			EA	LWT	TOT	SEN	kW	EER	TOT	kW	EER	THR
30	1.7	5.3	75/63	47.9	12928	9782	0.606	21.3	13073	0.569	23.0	15070
			80/67	49.1	13908	10125	0.595	23.4	14053	0.558	25.2	16033
			85/71	50.3	14949	10450	0.584	25.6	15093	0.547	27.6	17059
	2.4	10.7	75/63	42.7	13025	9825	0.581	22.4	13170	0.555	23.7	15088
			80/67	43.5	14028	10174	0.567	24.7	14172	0.541	26.2	16068
			85/71	44.4	15093	10504	0.551	27.4	15237	0.525	29.0	17095
	3.3	20.2	75/63	39.2	13093	9855	0.566	23.1	13237	0.566	23.4	15098
			80/67	39.8	14104	10206	0.549	25.7	14249	0.549	26.0	16074
			85/71	40.5	15179	10536	0.530	28.6	15324	0.530	28.9	17114
40	1.7	5.3	75/63	57.9	12698	9680	0.660	19.2	12842	0.623	20.6	15021
			80/67	59.1	13646	10019	0.654	20.9	13790	0.617	22.3	15982
			85/71	60.2	14656	10340	0.648	22.6	14800	0.611	24.2	16967
	2.4	10.7	75/63	52.7	12817	9733	0.633	20.2	12961	0.607	21.4	15053
			80/67	53.5	13792	10078	0.623	22.1	13936	0.597	23.3	16019
			85/71	54.4	14826	10404	0.611	24.3	14970	0.585	25.6	17021
	3.3	20.2	75/63	49.2	12890	9765	0.616	20.9	13034	0.616	21.2	15072
			80/67	49.8	13870	10110	0.602	23.0	14014	0.602	23.3	16035
			85/71	50.5	14930	10443	0.588	25.4	15075	0.588	25.7	17059
50	1.7	5.3	75/63	67.8	12416	9555	0.723	17.2	12560	0.686	18.3	14934
			80/67	69.0	13335	9893	0.721	18.5	13479	0.684	19.7	15867
			85/71	70.1	14308	10212	0.718	19.9	14453	0.681	21.2	16847
	2.4	10.7	75/63	62.7	12555	9617	0.692	18.1	12699	0.666	19.1	14988
			80/67	63.5	13500	9960	0.686	19.7	13644	0.660	20.7	15928
			85/71	64.3	14500	10283	0.680	21.3	14645	0.654	22.4	16914
	3.3	20.2	75/63	59.2	12642	9655	0.673	18.8	12787	0.673	19.0	15014
			80/67	59.8	13600	10000	0.664	20.5	13744	0.664	20.7	15955
			85/71	60.4	14622	10328	0.655	22.3	14766	0.655	22.6	16956
60	1.7	5.3	75/63	77.8	12085	9410	0.792	15.3	12229	0.755	16.2	14840
			80/67	78.9	12973	9747	0.795	16.3	13118	0.758	17.3	15751
			85/71	80.0	13908	10065	0.796	17.5	14053	0.759	18.5	16713
	2.4	10.7	75/63	72.6	12240	9479	0.760	16.1	12385	0.734	16.9	14883
			80/67	73.4	13152	9819	0.758	17.4	13296	0.732	18.2	15814
			85/71	74.2	14120	10142	0.755	18.7	14264	0.729	19.6	16778
	3.3	20.2	75/63	69.2	12341	9523	0.739	16.7	12486	0.739	16.9	14914
			80/67	69.8	13270	9867	0.734	18.1	13415	0.734	18.3	15853
			85/71	70.4	14257	10193	0.729	19.6	14402	0.729	19.8	16830
70	1.7	5.3	75/63	87.7	11706	9244	0.868	13.5	11851	0.831	14.3	14716
			80/67	88.7	12556	9580	0.874	14.4	12700	0.837	15.2	15592
			85/71	89.8	13459	9900	0.880	15.3	13604	0.843	16.1	16538
	2.4	10.7	75/63	82.5	11888	9324	0.834	14.3	12032	0.808	14.9	14766
			80/67	83.3	12766	9664	0.836	15.3	12910	0.810	15.9	15670
			85/71	84.1	13692	9985	0.837	16.4	13836	0.811	17.1	16635
	3.3	20.2	75/63	79.1	11989	9368	0.811	14.8	12134	0.811	15.0	14804
			80/67	79.7	12892	9715	0.811	15.9	13036	0.811	16.1	15718
			85/71	80.3	13840	10039	0.810	17.1	13984	0.810	17.3	16697
80	1.7	5.3	75/63	97.5	11278	9058	0.949	11.9	11422	0.912	12.5	14540
			80/67	98.5	12097	9396	0.959	12.6	12242	0.922	13.3	15405
			85/71	99.6	12965	9720	0.969	13.4	13109	0.932	14.1	16334
	2.4	10.7	75/63	92.4	11469	9142	0.914	12.5	11613	0.888	13.1	14615
			80/67	93.2	12314	9484	0.919	13.4	12458	0.893	14.0	15491
			85/71	94.0	13212	9810	0.925	14.3	13357	0.899	14.9	16445
	3.3	20.2	75/63	89.1	11590	9194	0.890	13.0	11734	0.890	13.2	14661
			80/67	89.6	12452	9538	0.894	13.9	12596	0.894	14.1	15551
			85/71	90.2	13372	9868	0.896	14.9	13517	0.896	15.1	16492
85	1.7	5.3	75/63	102.4	11051	8959	0.992	11.1	11195	0.955	11.7	14471
			80/67	103.4	11851	9299	1.004	11.8	11996	0.967	12.4	15300
			85/71	104.5	12700	9624	1.015	12.5	12844	0.978	13.1	16222
	2.4	10.7	75/63	97.4	11247	9045	0.956	11.8	11391	0.930	12.3	14543
			80/67	98.1	12075	9388	0.963	12.5	12219	0.937	13.0	15396
			85/71	98.9	12955	9716	0.970	13.4	13099	0.944	13.9	16323
	3.3	20.2	75/63	94.0	11372	9099	0.932	12.2	11516	0.932	12.4	14589
			80/67	94.6	12218	9445	0.937	13.0	12362	0.937	13.2	15456
			85/71	95.2	13118	9776	0.942	13.9	13263	0.942	14.1	16393
90	1.7	5.3	75/63	107.3	10816	8857	1.036	10.4	10961	0.999	11.0	14360
			80/67	108.3	11595	9196	1.050	11.0	11739	1.013	11.6	15209
			85/71	109.4	12423	9523	1.063	11.7	12567	1.026	12.2	16101
	2.4	10.7	75/63	102.3	11016	8945	0.999	11.0	11161	0.973	11.5	14443
			80/67	103.0	11826	9289	1.008	11.7	11970	0.982	12.2	15290
			85/71	103.8	12687	9619	1.017	12.5	12832	0.991	13.0	16205
	3.3	20.2	75/63	99.0	11144	9000	0.975	11.4	11288	0.975	11.6	14494
			80/67	99.5	11973	9347	0.982	12.2	12117	0.982	12.3	15353
			85/71	100.1	12855	9680	0.988	13.0	12999	0.988	13.2	16279
100	1.7	5.3	75/63	117.1	10312	8640	1.127	9.1	10456	1.090	9.6	14146
			80/67	118.1	11055	8983	1.143	9.7	11199	1.106	10.1	14976
			85/71	119.1	11844	9313	1.159	10.2	11989	1.122	10.7	15817
	2.4	10.7	75/63	112.2	10510	8725	1.089	9.7	10654	1.063	10.0	14238
			80/67	112.9	11296	9078	1.102	10.3	11440	1.076	10.6	15071
			85/71	113.6	12119	9412	1.114	10.9	12263	1.088	11.3	15946
	3.3	20.2	75/63	108.9	10663	8792	1.065	10.0	10807	1.065	10.2	14296
			80/67	109.4	11450	9140	1.075	10.7	11595	1.075	10.8	15139
			85/71	110.0	12294	9476	1.084	11.3	12439	1.084	11.5	16027
110	1.7	5.3	75/63	126.8	9767	8404	1.220	8.0	9911	1.183	8.4	13906
			80/67	127.8	10476	8753	1.240	8.4	10621	1.203	8.8	14691
			85/71	128.8	11215	9086	1.259	8.9	11360	1.222	9.3	15517
	2.4	10.7	75/63	122.0	9987	8500	1.183	8.4	10132	1.157	8.8	14004
			80/67	122.7	10713	8848	1.198	8.9	10858	1.172	9.3	14813
			85/71	123.4	11499	9189	1.214	9.5	11644	1.188	9.8	15655
	3.3	20.2	75/63	118.8	10140	8565	1.158	8.8	10285	1.158	8.9	14068
			80/67	119.3	10886	8916	1.172	9.3	11030	1.172	9.4	14887
			85/71	119.8	11682	9254	1.184	9.9	11826	1.184	10.0	15743

# Heating Capacity Data - Horizontal Unit Size 012

EWT	GPM	WPD	System Heating				ISO System Heating				
			EA	LWT	TOT	kW	COP	TOT	kW	COP	THA
20	1.7	5.3	60	12.8	8205	0.802	3.00	8061	0.765	3.08	5917
			70	13.1	8120	0.85	2.80	7976	0.813	2.87	5667
			80	13.4	8018	0.905	2.59	7874	0.868	2.65	5391
	2.4	10.7	60	14.7	8446	0.809	3.06	8302	0.783	3.11	6145
			70	14.9	8352	0.859	2.85	8208	0.833	2.89	5876
			80	15.2	8246	0.915	2.64	8101	0.889	2.67	5582
	3.3	20.2	60	16.0	8624	0.814	3.10	8479	0.814	3.05	6307
			70	16.2	8517	0.865	2.88	8373	0.865	2.84	6026
			80	16.4	8398	0.922	2.67	8254	0.922	2.62	5719
30	1.7	5.3	60	21.5	9352	0.835	3.28	9208	0.798	3.38	6981
			70	21.8	9262	0.893	3.04	9117	0.856	3.12	6698
			80	22.2	9162	0.956	2.81	9018	0.919	2.87	6385
	2.4	10.7	60	23.7	9650	0.844	3.35	9506	0.818	3.40	7261
			70	24.0	9547	0.903	3.10	9403	0.877	3.14	6958
			80	24.3	9432	0.968	2.85	9288	0.942	2.89	6624
	3.3	20.2	60	25.3	9868	0.85	3.40	9724	0.850	3.35	7464
			70	25.5	9754	0.91	3.14	9609	0.910	3.09	7145
			80	25.7	9625	0.976	2.89	9481	0.976	2.85	6795
40	1.7	5.3	60	30.0	10596	0.869	3.57	10451	0.832	3.68	8140
			70	30.4	10492	0.936	3.28	10347	0.899	3.37	7818
			80	30.8	10374	1.008	3.01	10230	0.971	3.08	7465
	2.4	10.7	60	32.6	10964	0.879	3.65	10820	0.853	3.71	8489
			70	32.9	10843	0.948	3.35	10698	0.922	3.40	8139
			80	33.3	10705	1.021	3.07	10561	0.995	3.11	7756
	3.3	20.2	60	34.5	11241	0.886	3.72	11097	0.886	3.67	8743
			70	34.7	11096	0.956	3.40	10952	0.956	3.36	8372
			80	35.0	10944	1.031	3.11	10799	1.031	3.07	7968
50	1.7	5.3	60	38.4	11939	0.905	3.86	11795	0.868	3.98	9396
			70	38.9	11811	0.98	3.53	11666	0.943	3.62	9026
			80	39.4	11675	1.06	3.22	11530	1.023	3.30	8623
	2.4	10.7	60	41.4	12398	0.916	3.96	12253	0.890	4.03	9833
			70	41.8	12248	0.994	3.61	12104	0.968	3.66	9429
			80	42.2	12078	1.075	3.29	11934	1.049	3.33	8991
	3.3	20.2	60	43.6	12738	0.925	4.03	12594	0.925	3.99	10146
			70	43.8	12559	1.004	3.66	12414	1.004	3.62	9713
			80	44.1	12368	1.087	3.33	12224	1.087	3.29	9246
60	1.7	5.3	60	46.7	13395	0.942	4.16	13250	0.905	4.29	10755
			70	47.2	13231	1.025	3.78	13086	0.988	3.88	10333
			80	47.8	13064	1.113	3.44	12920	1.076	3.51	9868
	2.4	10.7	60	50.1	13947	0.956	4.27	13803	0.930	4.35	11288
			70	50.5	13768	1.042	3.87	13624	1.016	3.93	10818
			80	51.0	13557	1.131	3.51	13413	1.105	3.55	10314
	3.3	20.2	60	52.6	14361	0.967	4.35	14216	0.967	4.31	11680
			70	52.9	14146	1.054	3.93	14002	1.054	3.89	11177
			80	53.2	13908	1.145	3.56	13764	1.145	3.52	10640
70	1.7	5.3	60	54.9	14940	0.981	4.46	14796	0.944	4.59	12216
			70	55.5	14760	1.073	4.03	14615	1.036	4.13	11728
			80	56.1	14560	1.168	3.65	14415	1.131	3.73	11203
	2.4	10.7	60	58.7	15634	0.999	4.58	15489	0.973	4.66	12866
			70	59.2	15397	1.093	4.12	15252	1.067	4.19	12316
			80	59.7	15132	1.189	3.73	14988	1.163	3.77	11739
	3.3	20.2	60	61.5	16130	1.012	4.67	15985	1.012	4.63	13329
			70	61.9	15859	1.108	4.19	15715	1.108	4.15	12746
			80	62.3	15564	1.205	3.78	15420	1.205	3.75	12129
80	1.7	5.3	60	62.9	16616	1.025	4.75	16471	0.988	4.88	13768
			70	63.6	16377	1.124	4.27	16232	1.087	4.37	13214
			80	64.4	16113	1.225	3.85	15969	1.188	3.93	12624
	2.4	10.7	60	67.2	17430	1.047	4.87	17286	1.021	4.96	14542
			70	67.8	17131	1.147	4.37	16987	1.121	4.44	13925
			80	68.4	16825	1.25	3.94	16680	1.224	3.99	13262
	3.3	20.2	60	70.4	18023	1.062	4.97	17879	1.062	4.93	15098
			70	70.8	17684	1.164	4.45	17540	1.164	4.41	14426
			80	71.2	17331	1.268	4.00	17187	1.268	3.97	13723
85	1.7	5.3	60	66.9	17485	1.048	4.89	17341	1.011	5.02	14586
			70	67.7	17217	1.15	4.38	17072	1.113	4.49	13987
			80	68.4	16939	1.254	3.96	16795	1.217	4.04	13363
	2.4	10.7	60	71.4	18366	1.071	5.02	18222	1.045	5.11	15416
			70	72.0	18051	1.176	4.49	17907	1.150	4.56	14754
			80	72.6	17697	1.281	4.05	17552	1.255	4.10	14061
	3.3	20.2	60	74.7	19020	1.089	5.11	18875	1.089	5.08	16038
			70	75.2	18645	1.195	4.57	18501	1.195	4.53	15306
			80	75.7	18244	1.301	4.11	18099	1.301	4.07	14555
90	1.7	5.3	60	70.9	18379	1.072	5.02	18234	1.035	5.16	15418
			70	71.7	18095	1.177	4.50	17950	1.140	4.61	14779
			80	72.5	17774	1.284	4.05	17630	1.247	4.14	14119
	2.4	10.7	60	75.6	19327	1.098	5.15	19183	1.072	5.24	16316
			70	76.3	18983	1.205	4.61	18839	1.179	4.68	15612
			80	76.9	18622	1.314	4.15	18477	1.288	4.20	14872
	3.3	20.2	60	79.1	20043	1.117	5.25	19898	1.117	5.22	16978
			70	79.6	19633	1.226	4.69	19489	1.226	4.66	16209
			80	80.1	19192	1.334	4.21	19048	1.334	4.18	15412

# Cooling Capacity Data – Horizontal Unit Size 019

EWT	GPM	WPD	System Cooling						ISO System Cooling			
			EA	LWT	TOT	SEN	kW	EER	TOT	KW	EER	THR
30	2.7	2.5	75/63	51.6	25099	17649	1.086	23.1	25714	0.910	28.2	29075
			80/67	53.1	27124	18239	1.069	25.4	27738	0.893	31.1	31068
			85/71	54.7	29276	18782	1.045	28.0	29891	0.869	34.4	33188
	3.9	5.2	75/63	45.5	26240	18179	1.033	25.4	26855	0.866	31.0	30065
			80/67	46.6	28404	18788	1.005	28.3	29018	0.838	34.6	32159
			85/71	47.7	30715	19349	0.970	31.7	31330	0.803	39.0	34401
	5.2	9.2	75/63	41.8	26951	18513	1.004	26.8	27566	0.854	32.3	30694
			80/67	42.7	29201	19135	0.970	30.1	29816	0.820	36.4	32857
			85/71	43.6	31619	19710	0.928	34.1	32234	0.778	41.4	35165
40	2.7	2.5	75/63	60.8	23627	16976	1.163	20.3	24242	0.987	24.6	27824
			80/67	62.2	25592	17592	1.153	22.2	26207	0.977	26.8	29784
			85/71	63.8	27663	18157	1.138	24.3	28277	0.962	29.4	31854
	3.9	5.2	75/63	54.8	24676	17454	1.108	22.3	25290	0.941	26.9	28704
			80/67	55.9	26762	18085	1.088	24.6	27377	0.921	29.7	30772
			85/71	57.0	28980	18666	1.061	27.3	29595	0.894	33.1	32966
	5.2	9.2	75/63	51.3	25310	17746	1.076	23.5	25924	0.926	28.0	29266
			80/67	52.1	27482	18392	1.050	26.2	28097	0.900	31.2	31386
			85/71	53.0	29802	18988	1.017	29.3	30417	0.867	35.1	33649
50	2.7	2.5	75/63	69.9	22200	16334	1.248	17.8	22815	1.072	21.3	26645
			80/67	71.4	24062	16957	1.246	19.3	24677	1.070	23.1	28574
			85/71	72.8	26042	17539	1.239	21.0	26657	1.063	25.1	30535
	3.9	5.2	75/63	64.2	23122	16747	1.192	19.4	23737	1.025	23.2	27431
			80/67	65.2	25135	17402	1.180	21.3	25750	1.013	25.4	29428
			85/71	66.3	27270	18006	1.162	23.5	27884	0.995	28.0	31544
	5.2	9.2	75/63	60.8	23689	17004	1.159	20.4	24304	1.009	24.1	27896
			80/67	61.6	25787	17675	1.142	22.6	26402	0.992	26.6	29938
			85/71	62.5	28000	18286	1.117	25.1	28615	0.967	29.6	32159
60	2.7	2.5	75/63	79.1	20750	15691	1.338	15.5	21365	1.162	18.4	25484
			80/67	80.5	22545	16338	1.345	16.8	23160	1.169	19.8	27345
			85/71	81.9	24430	16936	1.346	18.1	25044	1.170	21.4	29262
	3.9	5.2	75/63	73.6	21610	16071	1.283	16.8	22225	1.116	19.9	26192
			80/67	74.6	23532	16740	1.280	18.4	24147	1.113	21.7	28099
			85/71	75.6	25555	17356	1.271	20.1	26169	1.104	23.7	30138
	5.2	9.2	75/63	70.3	22145	16309	1.251	17.7	22760	1.101	20.7	26602
			80/67	71.1	24120	16982	1.243	19.4	24735	1.093	22.6	28603
			85/71	71.9	26232	17611	1.227	21.4	26847	1.077	24.9	30688
70	2.7	2.5	75/63	88.3	19333	15072	1.432	13.5	19947	1.256	15.9	24337
			80/67	89.6	21021	15725	1.446	14.5	21636	1.270	17.0	26106
			85/71	91.0	22810	16338	1.457	15.7	23425	1.281	18.3	27988
	3.9	5.2	75/63	83.0	20117	15413	1.379	14.6	20731	1.212	17.1	24952
			80/67	84.0	21932	16091	1.385	15.8	22546	1.218	18.5	26867
			85/71	85.0	23866	16727	1.385	17.2	24481	1.218	20.1	28831
	5.2	9.2	75/63	79.9	20586	15619	1.348	15.3	21201	1.198	17.7	25332
			80/67	80.6	22498	16319	1.349	16.7	23113	1.199	19.3	27279
			85/71	81.4	24487	16957	1.343	18.2	25101	1.193	21.0	29326
80	2.7	2.5	75/63	97.5	17908	14456	1.526	11.7	18523	1.350	13.7	23209
			80/67	98.8	19515	15128	1.550	12.6	20130	1.374	14.6	24944
			85/71	100.1	21215	15759	1.569	13.5	21830	1.393	15.7	26720
	3.9	5.2	75/63	92.4	18640	14772	1.477	12.6	19255	1.310	14.7	23791
			80/67	93.3	20362	15463	1.492	13.6	20976	1.325	15.8	25597
			85/71	94.3	22176	16108	1.501	14.8	22790	1.334	17.1	27497
	5.2	9.2	75/63	89.4	19076	14961	1.448	13.2	19691	1.298	15.2	24139
			80/67	90.1	20853	15659	1.458	14.3	21467	1.308	16.4	25976
			85/71	90.9	22749	16316	1.462	15.6	23364	1.312	17.8	27926
85	2.7	2.5	75/63	102.0	17197	14151	1.573	10.9	17812	1.397	12.7	22639
			80/67	103.3	18760	14830	1.601	11.7	19375	1.425	13.6	24328
			85/71	104.6	20396	15463	1.624	12.6	21011	1.448	14.5	26082
	3.9	5.2	75/63	97.1	17912	14458	1.526	11.7	18526	1.359	13.6	23210
			80/67	98.0	19575	15151	1.546	12.7	20190	1.379	14.6	24977
			85/71	99.0	21353	15809	1.559	13.7	21968	1.392	15.8	26826
	5.2	9.2	75/63	94.2	18320	14634	1.498	12.2	18935	1.348	14.0	23540
			80/67	94.8	20085	15353	1.511	13.3	20700	1.361	15.2	25380
			85/71	95.6	21898	16006	1.521	14.4	22513	1.371	16.4	27263
90	2.7	2.5	75/63	106.6	16492	13849	1.618	10.2	17106	1.442	11.9	22065
			80/67	107.9	18011	14536	1.651	10.9	18625	1.475	12.6	23726
			85/71	109.2	19586	15173	1.679	11.7	20200	1.503	13.4	25438
	3.9	5.2	75/63	101.8	17174	14142	1.574	10.9	17789	1.407	12.6	22620
			80/67	102.7	18795	14843	1.598	11.8	19409	1.431	13.6	24355
			85/71	103.6	20496	15499	1.618	12.7	21111	1.451	14.6	26161
	5.2	9.2	75/63	99.0	17572	14312	1.548	11.4	18186	1.398	13.0	22941
			80/67	99.7	19253	15024	1.567	12.3	19868	1.417	14.0	24721
			85/71	100.4	21029	15691	1.581	13.3	21644	1.431	15.1	26582
100	2.7	2.5	75/63	115.8	15087	13244	1.707	8.8	15702	1.531	10.3	20936
			80/67	117.0	16486	13938	1.749	9.4	17101	1.573	10.9	22508
			85/71	118.2	17966	14593	1.786	10.1	18580	1.610	11.5	24140
	3.9	5.2	75/63	111.2	15719	13517	1.668	9.4	16334	1.501	10.9	21454
			80/67	112.1	17222	14226	1.702	10.1	17837	1.535	11.6	23103
			85/71	113.0	18817	14897	1.731	10.9	19432	1.564	12.4	24825
	5.2	9.2	75/63	108.5	16085	13675	1.645	9.8	16700	1.495	11.2	21751
			80/67	109.2	17650	14394	1.674	10.5	18265	1.524	12.0	23447
			85/71	109.9	19314	15075	1.698	11.4	19929	1.548	12.9	25221
110	2.7	2.5	75/63	124.9	13666	12619	1.790	7.6	14281	1.614	8.8	19771
			80/67	126.1	14967	13335	1.841	8.1	15582	1.665	9.4	21262
			85/71	127.3	16336	14008	1.888	8.7	16951	1.712	9.9	22831
	3.9	5.2	75/63	120.6	14255	12881	1.756	8.1	14870	1.589	9.4	20259
			80/67	121.4	15652	13609	1.800	8.7	16267	1.633	10.0	21828
			85/71	122.3	17130	14295	1.839	9.3	17744	1.672	10.6	23462
	5.2	9.2	75/63	118.1	14595	13030	1.736	8.4	15210	1.586	9.6	20540
			80/67	118.7	16051	13766	1.776	9.0	16665	1.626	10.2	22154
			85/71	119.4	17593	14460	1.810	9.7	18208	1.660	11.0	23837

# Heating Capacity Data – Horizontal Unit Size 019

EWT	GPM	WPD	System Heating					ISO System Heating			
			EA	LWT	TOT	kW	COP	TOT	kW	COP	THA
20	2.7	2.5	60	13.8	11892	1.135	3.07	11277	0.959	3.44	8495
			70	14.4	11154	1.162	2.81	10539	0.986	3.13	7648
			80	15.0	10416	1.189	2.55	9801	1.013	2.83	6801
	3.9	5.2	60	15.5	12413	1.155	3.15	11799	0.988	3.50	8942
			70	16.0	11593	1.183	2.87	10978	1.016	3.16	8026
			80	16.5	10773	1.211	2.59	10158	1.044	2.85	7110
	5.2	9.2	60	16.5	12727	1.168	3.19	12112	1.018	3.48	9224
			70	16.9	11882	1.195	2.91	11267	1.045	3.16	8265
			80	17.3	11037	1.222	2.63	10423	1.072	2.85	7306
30	2.7	2.5	60	22.3	14231	1.224	3.40	13617	1.048	3.80	10577
			70	23.0	13432	1.264	3.11	12817	1.088	3.45	9626
			80	23.7	12637	1.299	2.85	12022	1.123	3.13	8693
	3.9	5.2	60	24.4	14886	1.248	3.49	14271	1.081	3.87	11165
			70	24.9	14016	1.288	3.19	13401	1.121	3.50	10135
			80	25.4	13149	1.324	2.91	12535	1.157	3.17	9126
	5.2	9.2	60	25.6	15314	1.262	3.55	14699	1.112	3.87	11544
			70	26.0	14372	1.303	3.23	13758	1.153	3.49	10457
			80	26.4	13478	1.339	2.95	12863	1.189	3.17	9398
40	2.7	2.5	60	30.6	16746	1.309	3.75	16131	1.133	4.17	12852
			70	31.4	15881	1.362	3.41	15266	1.186	3.77	11789
			80	32.1	15019	1.410	3.12	14404	1.234	3.42	10746
	3.9	5.2	60	33.1	17570	1.334	3.86	16955	1.167	4.26	13600
			70	33.7	16616	1.389	3.50	16001	1.222	3.83	12449
			80	34.3	15674	1.439	3.19	15059	1.272	3.47	11315
	5.2	9.2	60	34.6	18089	1.350	3.92	17474	1.200	4.26	14079
			70	35.1	17083	1.406	3.56	16468	1.256	3.84	12866
			80	35.6	16087	1.457	3.23	15473	1.307	3.47	11676
50	2.7	2.5	60	38.8	19402	1.387	4.10	18787	1.211	4.54	15300
			70	39.6	18492	1.454	3.72	17878	1.278	4.10	14134
			80	40.5	17560	1.517	3.39	16946	1.341	3.70	12979
	3.9	5.2	60	41.7	20425	1.414	4.23	19810	1.247	4.65	16250
			70	42.4	19414	1.484	3.83	18799	1.317	4.18	14963
			80	43.0	18377	1.550	3.47	17762	1.383	3.76	13696
	5.2	9.2	60	43.6	21067	1.430	4.31	20452	1.280	4.68	16854
			70	44.1	19991	1.503	3.89	19376	1.353	4.19	15490
			80	44.6	18891	1.569	3.53	18276	1.419	3.77	14153
60	2.7	2.5	60	46.8	22234	1.458	4.47	21619	1.282	4.94	17933
			70	47.7	21250	1.541	4.04	20635	1.365	4.43	16649
			80	48.7	20248	1.619	3.66	19633	1.443	3.98	15360
	3.9	5.2	60	50.3	23459	1.486	4.62	22844	1.319	5.07	19109
			70	51.0	22359	1.573	4.16	21745	1.406	4.53	17684
			80	51.7	21259	1.655	3.76	20644	1.488	4.06	16259
	5.2	9.2	60	52.4	24249	1.503	4.72	23634	1.353	5.11	19841
			70	53.0	23063	1.592	4.24	22448	1.442	4.56	18331
			80	53.6	21871	1.676	3.82	21257	1.526	4.08	16832
70	2.7	2.5	60	54.7	25174	1.522	4.84	24559	1.346	5.34	20722
			70	55.7	24110	1.620	4.36	23495	1.444	4.76	19316
			80	56.8	23054	1.715	3.94	22439	1.539	4.27	17909
	3.9	5.2	60	58.7	26649	1.550	5.03	26034	1.383	5.51	22140
			70	59.5	25459	1.653	4.51	24844	1.486	4.90	20572
			80	60.3	24260	1.752	4.05	23645	1.585	4.37	19004
	5.2	9.2	60	61.1	27445	1.563	5.14	26830	1.413	5.56	23090
			70	61.8	26296	1.673	4.60	25681	1.523	4.94	21360
			80	62.5	25011	1.775	4.13	24397	1.625	4.40	19688
80	2.7	2.5	60	62.5	28223	1.577	5.24	27608	1.401	5.77	23652
			70	63.6	27110	1.691	4.69	26496	1.515	5.12	22133
			80	64.8	25969	1.802	4.22	25354	1.626	4.57	20573
	3.9	5.2	60	67.0	29702	1.598	5.44	29087	1.431	5.95	25421
			70	67.9	28671	1.725	4.87	28056	1.558	5.27	23610
			80	68.8	27379	1.841	4.35	26764	1.674	4.68	21868
	5.2	9.2	60	69.9	31053	1.620	5.61	30438	1.470	6.06	26393
			70	70.6	29659	1.744	4.98	29045	1.594	5.34	24549
			80	71.3	28253	1.864	4.44	27638	1.714	4.72	22706
85	2.7	2.5	60	66.3	29539	1.596	5.42	28924	1.420	5.96	25265
			70	67.6	28637	1.724	4.86	28023	1.548	5.30	23556
			80	68.8	27447	1.843	4.36	26832	1.667	4.71	21942
	3.9	5.2	60	71.2	31668	1.629	5.69	31054	1.462	6.22	26985
			70	72.1	30335	1.757	5.06	29720	1.590	5.47	25178
			80	73.0	28964	1.882	4.51	28349	1.715	4.84	23363
	5.2	9.2	60	74.2	32840	1.644	5.85	32225	1.494	6.32	28130
			70	74.9	31367	1.776	5.17	30752	1.626	5.54	26194
			80	75.7	29890	1.904	4.60	29275	1.754	4.89	24247
90	2.7	2.5	60	70.2	31380	1.625	5.65	30766	1.449	6.22	26734
			70	71.5	30182	1.754	5.04	29567	1.578	5.49	25049
			80	72.7	28950	1.881	4.51	28335	1.705	4.87	23337
	3.9	5.2	60	75.3	33366	1.649	5.92	32751	1.482	6.47	28654
			70	76.3	31986	1.786	5.24	31371	1.619	5.67	26778
			80	77.2	30557	1.919	4.66	29942	1.752	5.01	24871
	5.2	9.2	60	78.5	34645	1.664	6.10	34030	1.514	6.58	29882
			70	79.3	33111	1.804	5.37	32496	1.654	5.75	27874
			80	80.1	31567	1.941	4.76	30952	1.791	5.06	25830

# Cooling Capacity Data – Horizontal Unit Size 024

EWT	GPM	WPD	System Cooling						ISO System Cooling			
			EA	LWT	TOT	SEN	kW	EER	TOT	kW	EER	THR
30	3.4	3.9	75/63	49.5	28013	20935	1.112	25.2	28687	0.923	31.1	32025
			80/67	50.8	30290	21686	1.084	27.9	30964	0.895	34.6	34199
			85/71	52.2	32643	22360	1.054	31.0	33317	0.865	38.5	36551
	4.9	8.2	75/63	43.7	28865	21331	1.001	28.8	29539	0.829	35.6	32493
			80/67	44.6	31193	22074	0.956	32.6	31867	0.784	40.6	34698
			85/71	45.6	33683	22769	0.906	37.2	34356	0.734	46.8	37074
	6.5	14.4	75/63	40.4	29328	21547	0.934	31.4	30002	0.796	37.7	32748
			80/67	41.1	31705	22295	0.878	36.1	32379	0.740	43.8	34968
			85/71	41.9	34241	22990	0.817	41.9	34915	0.679	51.5	37359
40	3.4	3.9	75/63	59.1	26811	20380	1.267	21.2	27485	1.078	25.5	31269
			80/67	60.4	28989	21135	1.251	23.2	29663	1.062	27.9	33419
			85/71	61.8	31289	21833	1.232	25.4	31963	1.043	30.6	35717
	4.9	8.2	75/63	53.4	27611	20749	1.166	23.7	28284	0.994	28.5	31752
			80/67	54.4	29908	21524	1.136	26.3	30581	0.964	31.7	33986
			85/71	55.3	32324	22235	1.100	29.4	32998	0.928	35.6	36317
	6.5	14.4	75/63	50.2	27491	20812	1.172	23.3	28165	1.034	27.3	32013
			80/67	50.9	30422	21743	1.066	28.5	31096	0.928	33.5	34289
			85/71	51.7	32900	22461	1.019	32.3	33573	0.881	38.1	36671
50	3.4	3.9	75/63	68.6	25489	19777	1.416	18.0	26163	1.227	21.3	30408
			80/67	69.9	27650	20572	1.412	19.6	28323	1.223	23.2	32574
			85/71	71.2	29827	21270	1.404	21.2	30501	1.215	25.1	34781
	4.9	8.2	75/63	63.1	26287	20140	1.327	19.8	26960	1.155	23.3	30951
			80/67	64.0	28521	20937	1.308	21.8	29195	1.136	25.7	33141
			85/71	65.0	30867	21670	1.285	24.0	31541	1.113	28.3	35452
	6.5	14.4	75/63	60.0	26761	20358	1.273	21.0	27435	1.135	24.2	31238
			80/67	60.7	29035	21154	1.246	23.3	29709	1.108	26.8	33445
			85/71	61.4	31436	21890	1.213	25.9	32110	1.075	29.9	35815
60	3.4	3.9	75/63	78.0	24115	19156	1.559	15.5	24789	1.370	18.1	29474
			80/67	79.3	26150	19948	1.566	16.7	26824	1.377	19.5	31579
			85/71	80.7	28300	20689	1.570	18.0	28974	1.381	21.0	33753
	4.9	8.2	75/63	72.7	24905	19512	1.479	16.8	25578	1.307	19.6	30033
			80/67	73.7	27055	20323	1.473	18.4	27729	1.301	21.3	32166
			85/71	74.6	29306	21071	1.462	20.0	29980	1.290	23.2	34430
	6.5	14.4	75/63	69.7	25354	19716	1.431	17.7	26027	1.293	20.1	30322
			80/67	70.4	27546	20528	1.417	19.4	28220	1.279	22.1	32523
			85/71	71.1	29884	21292	1.398	21.4	30558	1.260	24.3	34818
70	3.4	3.9	75/63	87.4	22696	18520	1.695	13.4	23370	1.506	15.5	28444
			80/67	88.7	24622	19319	1.713	14.4	25295	1.524	16.6	30481
			85/71	90.0	26664	20072	1.728	15.4	27338	1.539	17.8	32629
	4.9	8.2	75/63	82.3	23453	18859	1.623	14.5	24127	1.451	16.6	28988
			80/67	83.2	25508	19683	1.629	15.7	26182	1.457	18.0	31117
			85/71	84.2	27675	20453	1.631	17.0	28349	1.459	19.4	33353
	6.5	14.4	75/63	79.4	23896	19058	1.581	15.1	24570	1.443	17.0	29338
			80/67	80.1	26022	19895	1.580	16.5	26696	1.442	18.5	31474
			85/71	80.8	28248	20669	1.573	18.0	28922	1.435	20.2	33750
80	3.4	3.9	75/63	96.8	21192	17852	1.824	11.6	21866	1.635	13.4	27354
			80/67	98.0	23040	18673	1.853	12.4	23713	1.664	14.3	29345
			85/71	99.3	24981	19444	1.878	13.3	25655	1.689	15.2	31378
	4.9	8.2	75/63	91.9	21943	18185	1.760	12.5	22617	1.588	14.2	27914
			80/67	92.8	23899	19024	1.778	13.4	24573	1.606	15.3	29984
			85/71	93.7	25961	19810	1.792	14.5	26635	1.620	16.4	32106
	6.5	14.4	75/63	89.1	22385	18382	1.722	13.0	23059	1.584	14.6	28225
			80/67	89.7	24396	19227	1.733	14.1	25070	1.595	15.7	30317
			85/71	90.4	26533	20023	1.740	15.2	27207	1.602	17.0	32522
85	3.4	3.9	75/63	101.5	20431	17514	1.885	10.8	21105	1.696	12.4	26775
			80/67	102.7	22229	18344	1.919	11.6	22903	1.730	13.2	28720
			85/71	103.9	24092	19114	1.950	12.4	24766	1.761	14.1	30723
	4.9	8.2	75/63	96.7	21173	17843	1.826	11.6	21847	1.654	13.2	27336
			80/67	97.5	23073	18687	1.849	12.5	23747	1.677	14.2	29343
			85/71	98.4	25090	19484	1.869	13.4	25764	1.697	15.2	31463
	6.5	14.4	75/63	93.9	21612	18038	1.790	12.1	22286	1.652	13.5	27653
			80/67	94.5	23578	18892	1.806	13.1	24252	1.668	14.5	29726
			85/71	95.2	25649	19692	1.820	14.1	26322	1.682	15.7	31876
90	3.4	3.9	75/63	106.1	19659	17169	1.945	10.1	20332	1.756	11.6	26172
			80/67	107.3	21408	18009	1.985	10.8	22082	1.796	12.3	28089
			85/71	108.5	23210	18787	2.021	11.5	23884	1.832	13.0	30055
	4.9	8.2	75/63	101.4	20386	17494	1.889	10.8	21060	1.717	12.3	26739
			80/67	102.3	22241	18348	1.919	11.6	22915	1.747	13.1	28727
			85/71	103.1	24172	19143	1.944	12.4	24845	1.772	14.0	30787
	6.5	14.4	75/63	98.7	20816	17684	1.856	11.2	21490	1.718	12.5	27058
			80/67	99.4	22720	18543	1.879	12.1	23394	1.741	13.4	29091
			85/71	100.0	24728	19350	1.898	13.0	25402	1.760	14.4	31204
100	3.4	3.9	75/63	115.4	18099	16470	2.061	8.8	18772	1.872	10.0	24966
			80/67	116.5	19709	17316	2.110	9.3	20382	1.921	10.6	26776
			85/71	117.7	21399	18115	2.157	9.9	22073	1.968	11.2	28645
	4.9	8.2	75/63	110.9	18791	16782	2.011	9.3	19464	1.839	10.6	25513
			80/67	111.7	20517	17647	2.051	10.0	21191	1.879	11.3	27410
			85/71	112.6	22332	18461	2.088	10.7	23006	1.916	12.0	29376
	6.5	14.4	75/63	108.3	19185	16958	1.981	9.7	19859	1.843	10.8	25800
			80/67	108.9	20996	17842	2.017	10.4	21669	1.879	11.5	27769
			85/71	109.6	22866	18659	2.047	11.2	23540	1.909	12.3	29789
110	3.4	3.9	75/63	124.6	16489	15726	2.171	7.6	17163	1.982	8.7	23687
			80/67	125.7	17984	16597	2.230	8.1	18658	2.041	9.1	25408
			85/71	126.8	19543	17417	2.286	8.5	20217	2.097	9.6	27189
	4.9	8.2	75/63	120.4	17153	16038	2.126	8.1	17827	1.954	9.1	24221
			80/67	121.1	18754	16921	2.177	8.6	19428	2.005	9.7	26017
			85/71	121.9	20435	17755	2.225	9.2	21109	2.053	10.3	27879
	6.5	14.4	75/63	117.9	17544	16217	2.100	8.4	18218	1.962	9.3	24522
			80/67	118.5	19195	17104	2.147	8.9	19869	2.009	9.9	26368
			85/71	119.1	20947	17947	2.189	9.6	21620	2.051	10.5	28286

# Heating Capacity Data – Horizontal Unit Size 024

EWT	GPM	WPD	System Heating					ISO System Heating			
			EA	LWT	TOT	kW	COP	TOT	kW	COP	THA
20	3.4	3.9	60	14.2	14277	1.378	3.03	13603	1.189	3.35	10115
			70	14.8	13446	1.417	2.78	12772	1.228	3.05	9125
			80	15.4	12615	1.456	2.52	11941	1.267	2.76	8135
	4.9	8.2	60	15.8	14870	1.399	3.11	14196	1.227	3.39	10643
			70	16.2	13968	1.439	2.84	13294	1.267	3.07	9580
			80	16.6	13066	1.479	2.57	12393	1.307	2.78	8517
	6.5	14.4	60	16.7	15238	1.411	3.16	14564	1.273	3.35	10967
			70	17.1	14283	1.452	2.88	13609	1.314	3.03	9865
			80	17.5	13327	1.493	2.60	12653	1.355	2.74	8763
30	3.4	3.9	60	22.7	17153	1.474	3.41	16479	1.285	3.75	12721
			70	23.3	16283	1.529	3.12	15609	1.340	3.41	11640
			80	24.0	15413	1.578	2.86	14740	1.389	3.11	10581
	4.9	8.2	60	24.7	17917	1.497	3.50	17244	1.325	3.81	13419
			70	25.1	16976	1.555	3.20	16302	1.383	3.45	12254
			80	25.6	16030	1.605	2.92	15356	1.433	3.14	11117
	6.5	14.4	60	25.9	18412	1.512	3.57	17739	1.374	3.78	13855
			70	26.2	17395	1.57	3.24	16721	1.432	3.42	12638
			80	26.6	16421	1.621	2.97	15747	1.483	3.11	11440
40	3.4	3.9	60	31.1	20256	1.565	3.79	19582	1.376	4.17	15569
			70	31.8	19333	1.638	3.46	18660	1.449	3.77	14374
			80	32.4	18396	1.704	3.16	17722	1.515	3.43	13191
	4.9	8.2	60	33.4	21225	1.591	3.91	20551	1.419	4.24	16461
			70	34.0	20210	1.667	3.55	19536	1.495	3.83	15170
			80	34.5	19183	1.735	3.24	18509	1.563	3.47	13885
	6.5	14.4	60	34.9	21830	1.607	3.98	21156	1.469	4.22	17026
			70	35.3	20760	1.685	3.61	20087	1.547	3.80	15668
			80	35.7	19674	1.754	3.28	19001	1.616	3.44	14324
50	3.4	3.9	60	39.3	23543	1.651	4.18	22869	1.462	4.58	18628
			70	40.0	22575	1.742	3.79	21902	1.553	4.13	17315
			80	40.8	21559	1.826	3.46	20885	1.637	3.74	15996
	4.9	8.2	60	42.1	24744	1.681	4.31	24070	1.509	4.67	19752
			70	42.7	23675	1.776	3.90	23001	1.604	4.20	18319
			80	43.3	22538	1.862	3.54	21864	1.690	3.79	16878
	6.5	14.4	60	43.8	25501	1.699	4.39	24827	1.561	4.66	20460
			70	44.3	24348	1.796	3.97	23674	1.658	4.18	18931
			80	44.8	23139	1.885	3.59	22465	1.747	3.77	17406
60	3.4	3.9	60	47.4	26884	1.732	4.55	26211	1.543	4.97	21896
			70	48.2	25971	1.844	4.12	25297	1.655	4.48	20428
			80	49.1	24853	1.946	3.74	24179	1.757	4.03	18951
	4.9	8.2	60	50.7	28465	1.767	4.72	27791	1.595	5.10	23254
			70	51.3	27290	1.882	4.25	26616	1.710	4.56	21648
			80	52.0	26064	1.987	3.84	25390	1.815	4.10	20016
	6.5	14.4	60	52.7	29370	1.787	4.81	28696	1.649	5.10	24117
			70	53.2	28110	1.904	4.32	27437	1.766	4.55	22423
			80	53.8	26800	2.012	3.90	26126	1.874	4.08	20676
70	3.4	3.9	60	55.4	30632	1.815	4.94	29958	1.626	5.39	25290
			70	56.3	29495	1.942	4.45	28821	1.753	4.81	23690
			80	57.3	28284	2.063	4.01	27610	1.874	4.31	22055
	4.9	8.2	60	59.2	32351	1.851	5.12	31677	1.679	5.52	26946
			70	59.9	31065	1.984	4.58	30391	1.812	4.91	25153
			80	60.7	29705	2.109	4.12	29031	1.937	4.39	23325
	6.5	14.4	60	61.6	33457	1.874	5.23	32784	1.736	5.53	27957
			70	62.1	32035	2.01	4.67	31362	1.872	4.91	26058
			80	62.7	30571	2.137	4.19	29897	1.999	4.38	24124
80	3.4	3.9	60	63.3	34400	1.893	5.32	33726	1.704	5.80	28856
			70	64.3	33149	2.039	4.76	32476	1.850	5.14	27083
			80	65.4	31827	2.177	4.28	31154	1.988	4.59	25249
	4.9	8.2	60	67.7	36421	1.933	5.52	35747	1.761	5.94	30758
			70	68.4	34968	2.084	4.91	34295	1.912	5.25	28776
			80	69.3	33460	2.228	4.40	32786	2.056	4.67	26733
	6.5	14.4	60	70.3	37611	1.956	5.63	36938	1.818	5.95	31980
			70	71.0	36066	2.112	5.00	35392	1.974	5.25	29828
			80	71.6	34450	2.258	4.47	33776	2.120	4.67	27657
85	3.4	3.9	60	67.2	36338	1.932	5.51	35665	1.743	5.99	30676
			70	68.3	35004	2.085	4.92	34330	1.896	5.30	28822
			80	69.4	33620	2.233	4.41	32946	2.044	4.72	26880
	4.9	8.2	60	71.9	38444	1.972	5.71	37771	1.800	6.14	32722
			70	72.7	36942	2.133	5.07	36268	1.961	5.42	30637
			80	73.6	35354	2.285	4.53	34681	2.113	4.81	28478
	6.5	14.4	60	74.7	39766	1.997	5.83	39093	1.859	6.16	34006
			70	75.4	38124	2.161	5.17	37450	2.023	5.42	31753
			80	76.1	36403	2.316	4.60	35729	2.178	4.80	29450
90	3.4	3.9	60	71.1	37930	1.96	5.67	37256	1.771	6.16	32639
			70	72.3	36873	2.131	5.07	36199	1.942	5.46	30577
			80	73.5	35424	2.287	4.54	34750	2.098	4.85	28524
	4.9	8.2	60	76.0	40512	2.011	5.90	39839	1.839	6.34	34700
			70	76.9	38922	2.18	5.23	38248	2.008	5.58	32502
			80	77.8	37259	2.341	4.66	36585	2.169	4.94	30240
	6.5	14.4	60	79.1	41942	2.036	6.03	41268	1.898	6.37	36041
			70	79.8	40178	2.209	5.33	39504	2.071	5.59	33724
			80	80.5	38378	2.373	4.74	37704	2.235	4.94	31270

# Cooling Capacity Data – Horizontal Unit Size 030

EWT	GPM	WPD	System Cooling						ISO System Cooling			
			EA	LWT	TOT	SEN	kW	EER	TOT	kW	EER	THR
30	4.3	2.3	75/63	47.4	31840	24794	1.162	27.4	32669	0.926	35.3	35972
			80/67	48.5	34172	25634	1.173	29.1	35000	0.937	37.4	38395
			85/71	49.7	36630	26419	1.186	30.9	37458	0.950	39.4	40895
	6.1	4.6	75/63	42.2	32314	25010	1.042	31.0	33142	0.817	40.6	36049
			80/67	43.1	34722	25864	1.043	33.3	35551	0.818	43.5	38511
			85/71	44.0	37255	26659	1.047	35.6	38084	0.822	46.3	41103
	8.1	8.2	75/63	39.2	32594	25138	0.966	33.7	33423	0.765	43.7	36106
			80/67	39.9	35047	26000	0.961	36.5	35876	0.760	47.2	38621
			85/71	40.5	37633	26804	0.959	39.2	38462	0.758	50.7	41205
40	4.3	2.3	75/63	57.3	30927	24380	1.368	22.6	31756	1.132	28.1	35718
			80/67	58.4	33202	25230	1.379	24.1	34031	1.143	29.8	38056
			85/71	59.6	35553	26008	1.393	25.5	36382	1.157	31.5	40509
	6.1	4.6	75/63	52.2	31409	24598	1.263	24.9	32238	1.038	31.1	35865
			80/67	53.0	33758	25460	1.265	26.7	34587	1.040	33.3	38224
			85/71	53.9	36167	26242	1.271	28.5	36996	1.046	35.4	40792
	8.1	8.2	75/63	49.2	31699	24730	1.197	26.5	32528	0.996	32.7	35952
			80/67	49.8	34075	25593	1.195	28.5	34903	0.994	35.1	38365
			85/71	50.5	36593	26405	1.195	30.6	37422	0.994	37.6	40915
50	4.3	2.3	75/63	67.2	29965	23945	1.562	19.2	30793	1.326	23.2	35386
			80/67	68.2	32135	24787	1.574	20.4	32964	1.338	24.6	37619
			85/71	69.4	34433	25584	1.590	21.7	35262	1.354	26.1	40010
	6.1	4.6	75/63	62.2	30454	24166	1.465	20.8	31282	1.240	25.2	35579
			80/67	62.9	32702	25021	1.471	22.2	33530	1.246	26.9	37898
			85/71	63.8	35082	25830	1.478	23.7	35911	1.253	28.7	40320
	8.1	8.2	75/63	59.2	30747	24298	1.405	21.9	31575	1.204	26.2	35653
			80/67	59.8	33043	25164	1.406	23.5	33871	1.205	28.1	38001
			85/71	60.4	35469	25977	1.409	25.2	36298	1.208	30.0	40499
60	4.3	2.3	75/63	77.0	28927	23480	1.752	16.5	29755	1.516	19.6	34927
			80/67	78.0	31027	24331	1.767	17.6	31856	1.531	20.8	37127
			85/71	79.2	33255	25141	1.784	18.6	34084	1.548	22.0	39446
	6.1	4.6	75/63	72.0	29445	23712	1.659	17.7	30274	1.434	21.1	35126
			80/67	72.8	31614	24573	1.666	19.0	32443	1.441	22.5	37377
			85/71	73.6	33919	25390	1.676	20.2	34748	1.451	23.9	39789
	8.1	8.2	75/63	69.1	29744	23846	1.604	18.5	30573	1.403	21.8	35279
			80/67	69.7	31955	24713	1.606	19.9	32784	1.405	23.3	37538
			85/71	70.3	34307	25537	1.612	21.3	35136	1.411	24.9	39990
70	4.3	2.3	75/63	86.8	27851	23000	1.948	14.3	28679	1.712	16.8	34466
			80/67	87.8	29869	23857	1.964	15.2	30698	1.728	17.8	36601
			85/71	88.9	31991	24668	1.983	16.1	32820	1.747	18.8	38843
	6.1	4.6	75/63	81.9	28363	23228	1.855	15.3	29192	1.630	17.9	34695
			80/67	82.7	30461	24099	1.864	16.3	31290	1.639	19.1	36885
			85/71	83.4	32688	24928	1.875	17.4	33517	1.650	20.3	39160
	8.1	8.2	75/63	79.0	28674	23367	1.799	15.9	29503	1.598	18.5	34828
			80/67	79.6	30810	24242	1.804	17.1	31639	1.603	19.7	37002
			85/71	80.2	33085	25076	1.812	18.3	33914	1.611	21.1	39360
80	4.3	2.3	75/63	96.6	26680	22478	2.159	12.4	27508	1.923	14.3	33976
			80/67	97.6	28646	23358	2.176	13.2	29475	1.940	15.2	36025
			85/71	98.6	30674	24178	2.197	14.0	31503	1.961	16.1	38175
	6.1	4.6	75/63	91.8	27222	22719	2.059	13.2	28050	1.834	15.3	34197
			80/67	92.5	29251	23604	2.070	14.1	30080	1.845	16.3	36303
			85/71	93.2	31371	24436	2.083	15.1	32200	1.858	17.3	38514
	8.1	8.2	75/63	88.9	27535	22860	2.002	13.8	28364	1.801	15.7	34334
			80/67	89.4	29607	23749	2.009	14.7	30436	1.808	16.8	36468
			85/71	90.0	31777	24587	2.018	15.7	32605	1.817	17.9	38715
85	4.3	2.3	75/63	101.5	26081	22213	2.271	11.5	26910	2.035	13.2	33712
			80/67	102.4	28004	23098	2.290	12.2	28832	2.054	14.0	35738
			85/71	103.5	29990	23924	2.312	13.0	30819	2.076	14.8	37866
	6.1	4.6	75/63	96.6	26636	22460	2.165	12.3	27465	1.940	14.2	33967
			80/67	97.4	28625	23350	2.180	13.1	29454	1.955	15.1	36011
			85/71	98.1	30696	24185	2.193	14.0	31524	1.968	16.0	38185
	8.1	8.2	75/63	93.8	26946	22598	2.110	12.8	27775	1.909	14.5	34079
			80/67	94.4	28980	23494	2.117	13.7	29808	1.916	15.6	36178
			85/71	94.9	31105	24337	2.126	14.6	31934	1.925	16.6	38384
90	4.3	2.3	75/63	106.3	25460	21938	2.390	10.7	26289	2.154	12.2	33462
			80/67	107.3	27350	22832	2.410	11.3	28179	2.174	13.0	35459
			85/71	108.3	29290	23665	2.432	12.0	30119	2.196	13.7	37526
	6.1	4.6	75/63	101.6	26017	22185	2.283	11.4	26846	2.058	13.0	33687
			80/67	102.3	27975	23086	2.295	12.2	28804	2.070	13.9	35727
			85/71	103.0	30003	23929	2.309	13.0	30832	2.084	14.8	37855
	8.1	8.2	75/63	98.8	26338	22327	2.222	11.9	27166	2.021	13.4	33822
			80/67	99.3	28321	23226	2.230	12.7	29150	2.029	14.4	35898
			85/71	99.8	30413	24081	2.239	13.6	31242	2.038	15.3	38057
100	4.3	2.3	75/63	116.2	24162	21364	2.657	9.1	24991	2.421	10.3	33027
			80/67	117.1	25937	22259	2.677	9.7	26765	2.441	11.0	34908
			85/71	118.1	27811	23118	2.699	10.3	28640	2.463	11.6	36888
	6.1	4.6	75/63	111.5	24740	21620	2.536	9.8	25569	2.311	11.1	33225
			80/67	112.1	26594	22525	2.548	10.4	27423	2.323	11.8	35160
			85/71	112.8	28550	23392	2.563	11.1	29379	2.338	12.6	37199
	8.1	8.2	75/63	108.7	25070	21766	2.468	10.2	25899	2.267	11.4	33316
			80/67	109.2	26988	22685	2.477	10.9	27817	2.276	12.2	35312
			85/71	109.7	28975	23548	2.487	11.7	29803	2.286	13.0	37385
110	4.3	2.3	75/63	126.0	22753	20738	2.965	7.7	23581	2.729	8.6	32605
			80/67	126.9	24448	21655	2.984	8.2	25277	2.748	9.2	34391
			85/71	127.8	26219	22529	3.007	8.7	27048	2.771	9.8	36265
	6.1	4.6	75/63	121.3	23380	21017	2.828	8.3	24209	2.603	9.3	32780
			80/67	122.0	25136	21934	2.839	8.9	25965	2.614	9.9	34621
			85/71	122.6	26997	22817	2.854	9.5	27826	2.629	10.6	36560
	8.1	8.2	75/63	118.6	23725	21170	2.751	8.6	24554	2.550	9.6	32886
			80/67	119.0	25528	22093	2.759	9.3	26357	2.558	10.3	34759
			85/71	119.6	27439	22981	2.769	9.9	28268	2.568	11.0	36735



# Heating Capacity Data – Horizontal Unit Size 030

EWT	GPM	WPD	System Heating					ISO System Heating			
			EA	LWT	TOT	kW	COP	TOT	kW	COP	THA
20	4.3	2.3	60	13.4	20693	1.890	3.21	19864	1.654	3.52	14869
			70	13.7	20644	2.093	2.89	19815	1.857	3.13	14110
			80	14.1	20641	2.328	2.60	19812	2.092	2.77	13276
	6.1	4.6	60	15.2	21267	1.898	3.28	20438	1.673	3.58	15425
			70	15.4	21190	2.103	2.95	20362	1.878	3.17	14614
			80	15.7	21123	2.338	2.65	20294	2.113	2.81	13732
	8.1	8.2	60	16.3	21638	1.904	3.33	20810	1.703	3.58	15784
			70	16.5	21525	2.108	2.99	20696	1.907	3.18	14948
			80	16.7	21432	2.344	2.68	20603	2.143	2.82	14023
30	4.3	2.3	60	22.2	23504	1.931	3.56	22676	1.695	3.92	17599
			70	22.5	23382	2.14	3.20	22553	1.904	3.47	16730
			80	23.0	23298	2.379	2.87	22470	2.143	3.07	15790
	6.1	4.6	60	24.2	24228	1.942	3.65	23400	1.717	3.99	18308
			70	24.5	24052	2.151	3.27	23223	1.926	3.53	17377
			80	24.9	23913	2.391	2.93	23084	2.166	3.12	16376
	8.1	8.2	60	25.6	24699	1.948	3.71	23870	1.747	4.00	18765
			70	25.8	24484	2.158	3.32	23656	1.957	3.54	17794
			80	26.0	24303	2.398	2.97	23474	2.197	3.13	16752
40	4.3	2.3	60	30.8	26611	1.976	3.94	25782	1.740	4.34	20617
			70	31.2	26390	2.189	3.53	25562	1.953	3.83	19638
			80	31.7	26209	2.434	3.15	25380	2.198	3.38	18593
	6.1	4.6	60	33.2	27518	1.989	4.05	26690	1.764	4.43	21503
			70	33.6	27232	2.203	3.62	26403	1.978	3.91	20447
			80	33.9	26984	2.449	3.23	26155	2.224	3.44	19319
	8.1	8.2	60	34.8	28105	1.998	4.12	27277	1.797	4.44	22079
			70	35.0	27775	2.213	3.68	26946	2.012	3.92	20972
			80	35.3	27482	2.458	3.27	26653	2.257	3.46	19795
50	4.3	2.3	60	39.3	30017	2.027	4.34	29189	1.791	4.77	23910
			70	39.8	29669	2.246	3.87	28841	2.010	4.20	22806
			80	40.3	29409	2.496	3.45	28580	2.260	3.70	21635
	6.1	4.6	60	42.1	31148	2.045	4.46	30320	1.820	4.88	25009
			70	42.5	30742	2.265	3.97	29913	2.040	4.29	23830
			80	42.9	30375	2.516	3.54	29546	2.291	3.78	22567
	8.1	8.2	60	43.9	31890	2.057	4.54	31061	1.856	4.90	25718
			70	44.2	31417	2.277	4.04	30588	2.076	4.31	24468
			80	44.5	30995	2.529	3.59	30167	2.328	3.79	23142
60	4.3	2.3	60	47.7	33529	2.083	4.71	32700	1.847	5.19	27485
			70	48.2	33264	2.313	4.21	32435	2.077	4.57	26238
			80	48.8	32869	2.569	3.75	32040	2.333	4.02	24930
	6.1	4.6	60	50.9	35093	2.112	4.87	34264	1.887	5.32	28807
			70	51.3	34576	2.339	4.33	33748	2.114	4.67	27474
			80	51.7	34080	2.597	3.84	33252	2.372	4.10	26060
	8.1	8.2	60	52.9	35979	2.128	4.95	35150	1.927	5.34	29699
			70	53.3	35405	2.356	4.40	34577	2.155	4.70	28282
			80	53.6	34843	2.615	3.90	34014	2.414	4.13	26774
70	4.3	2.3	60	55.9	37507	2.156	5.09	36679	1.920	5.60	31282
			70	56.5	37140	2.393	4.54	36311	2.157	4.93	29902
			80	57.2	36650	2.658	4.04	35821	2.422	4.33	28443
	6.1	4.6	60	59.6	39190	2.189	5.24	38361	1.964	5.72	32905
			70	60.0	38710	2.428	4.67	37881	2.203	5.04	31386
			80	60.5	38059	2.693	4.14	37230	2.468	4.42	29801
	8.1	8.2	60	61.9	40439	2.216	5.34	39610	2.015	5.76	33939
			70	62.3	39732	2.451	4.75	38903	2.250	5.06	32348
			80	62.7	39012	2.718	4.20	38183	2.517	4.44	30678
80	4.3	2.3	60	64.1	41929	2.248	5.46	41100	2.012	5.98	35321
			70	64.8	41273	2.488	4.86	40444	2.252	5.26	33778
			80	65.5	40639	2.762	4.31	39810	2.526	4.62	32164
	6.1	4.6	60	68.2	43762	2.288	5.60	42933	2.063	6.09	37231
			70	68.7	43139	2.535	4.98	42310	2.310	5.36	35548
			80	69.3	42366	2.81	4.41	41538	2.585	4.71	33781
	8.1	8.2	60	70.8	45263	2.324	5.70	44434	2.123	6.13	38457
			70	71.2	44351	2.567	5.06	43522	2.366	5.39	36663
			80	71.7	43472	2.842	4.48	42643	2.641	4.73	34785
85	4.3	2.3	60	68.1	44133	2.297	5.63	43305	2.061	6.15	37419
			70	68.8	43422	2.542	5.00	42593	2.306	5.41	35782
			80	69.6	42722	2.82	4.44	41893	2.584	4.75	34086
	6.1	4.6	60	72.4	46366	2.351	5.77	45537	2.126	6.27	39439
			70	73.0	45485	2.597	5.13	44656	2.372	5.51	37684
			80	73.6	44580	2.875	4.54	43751	2.650	4.83	35820
	8.1	8.2	60	75.2	47747	2.385	5.86	46918	2.184	6.29	40768
			70	75.7	46783	2.633	5.20	45954	2.432	5.53	38900
			80	76.2	45776	2.912	4.60	44947	2.711	4.85	36905
90	4.3	2.3	60	72.1	46469	2.353	5.78	45640	2.117	6.31	39516
			70	72.9	45669	2.602	5.14	44840	2.366	5.55	37825
			80	73.7	44856	2.884	4.55	44027	2.648	4.87	36040
	6.1	4.6	60	76.7	48864	2.412	5.93	48035	2.187	6.43	41766
			70	77.3	47850	2.664	5.26	47022	2.439	5.65	39890
			80	77.9	46913	2.948	4.66	46084	2.723	4.96	37886
	8.1	8.2	60	79.6	50345	2.451	6.01	49516	2.250	6.44	43197
			70	80.1	49274	2.706	5.33	48446	2.505	5.66	41202
			80	80.6	48166	2.989	4.72	47337	2.788	4.97	39064

# Cooling Capacity Data - Horizontal Unit Size 036

EWT	GPM	WPD	System Cooling						ISO System Cooling			
			EA	LWT	TOT	SEN	kW	EER	TOT	kW	EER	THR
30	5.2	3.4	75/63	47.3	38579	29360	1.618	23.8	39348	1.404	28.0	44297
			80/67	48.5	41387	30347	1.649	25.1	42157	1.435	29.4	47295
			85/71	49.7	44336	31266	1.683	26.3	45106	1.469	30.7	50380
	7.3	6.6	75/63	42.4	39124	29604	1.516	25.8	39894	1.321	30.2	44516
			80/67	43.2	42034	30612	1.544	27.2	42804	1.349	31.7	47603
			85/71	44.1	45110	31556	1.574	28.7	45880	1.379	33.3	50798
	9.8	11.9	75/63	39.2	39462	29756	1.448	27.3	40232	1.296	31.0	44644
			80/67	39.9	42464	30789	1.474	28.8	43234	1.322	32.7	47774
			85/71	40.6	45571	31729	1.501	30.4	46341	1.349	34.4	51045
40	5.2	3.4	75/63	57.2	37468	28866	1.807	20.7	38238	1.593	24.0	43782
			80/67	58.3	40190	29857	1.834	21.9	40960	1.620	25.3	46662
			85/71	59.5	43015	30771	1.863	23.1	43785	1.649	26.6	49647
	7.3	6.6	75/63	52.3	38041	29121	1.712	22.2	38811	1.517	25.6	44080
			80/67	53.1	40850	30126	1.734	23.6	41620	1.539	27.0	47008
			85/71	54.0	43787	31059	1.759	24.9	44557	1.564	28.5	50064
	9.8	11.9	75/63	49.2	38395	29278	1.650	23.3	39165	1.498	26.1	44209
			80/67	49.8	41263	30296	1.670	24.7	42033	1.518	27.7	47231
			85/71	50.5	44274	31242	1.692	26.2	45044	1.540	29.3	50339
50	5.2	3.4	75/63	67.0	36284	28341	1.999	18.2	37054	1.785	20.8	43214
			80/67	68.1	38866	29318	2.022	19.2	39636	1.808	21.9	45947
			85/71	69.2	41606	30247	2.048	20.3	42376	1.834	23.1	48820
	7.3	6.6	75/63	62.2	36854	28592	1.906	19.3	37624	1.711	22.0	43493
			80/67	63.0	39564	29602	1.925	20.6	40334	1.730	23.3	46346
			85/71	63.8	42388	30538	1.946	21.8	43158	1.751	24.7	49294
	9.8	11.9	75/63	59.1	37219	28755	1.847	20.2	37989	1.695	22.4	43668
			80/67	59.7	39978	29770	1.864	21.4	40748	1.712	23.8	46599
			85/71	60.3	42879	30720	1.882	22.8	43649	1.730	25.2	49587
60	5.2	3.4	75/63	76.8	34971	27762	2.201	15.9	35741	1.987	18.0	42552
			80/67	77.8	37468	28753	2.222	16.9	38238	2.008	19.0	45213
			85/71	78.9	40113	29695	2.246	17.9	40883	2.032	20.1	47967
	7.3	6.6	75/63	72.0	35592	28036	2.106	16.9	36362	1.911	19.0	42868
			80/67	72.8	38165	29034	2.122	18.0	38935	1.927	20.2	45562
			85/71	73.6	40904	29987	2.141	19.1	41674	1.946	21.4	48428
	9.8	11.9	75/63	69.0	35975	28204	2.048	17.6	36745	1.896	19.4	43057
			80/67	69.6	38599	29210	2.060	18.7	39369	1.908	20.6	45802
			85/71	70.2	41402	30171	2.076	19.9	42172	1.924	21.9	48742
70	5.2	3.4	75/63	86.5	33580	27152	2.422	13.9	34349	2.208	15.6	41914
			80/67	87.5	35996	28161	2.442	14.7	36766	2.228	16.5	44434
			85/71	88.6	38547	29120	2.465	15.6	39317	2.251	17.5	47103
	7.3	6.6	75/63	81.9	34196	27422	2.322	14.7	34966	2.127	16.4	42214
			80/67	82.6	36697	28442	2.336	15.7	37467	2.141	17.5	44774
			85/71	83.4	39342	29412	2.353	16.7	40112	2.158	18.6	47563
	9.8	11.9	75/63	78.9	34591	27596	2.260	15.3	35361	2.108	16.8	42382
			80/67	79.4	37139	28620	2.271	16.4	37909	2.119	17.9	45005
			85/71	80.0	39841	29595	2.284	17.4	40611	2.132	19.1	47808
80	5.2	3.4	75/63	96.3	32111	26510	2.671	12.0	32881	2.457	13.4	41194
			80/67	97.2	34430	27533	2.691	12.8	35200	2.477	14.2	43663
			85/71	98.2	36873	28508	2.712	13.6	37643	2.498	15.1	46234
	7.3	6.6	75/63	91.7	32763	26795	2.562	12.8	33533	2.367	14.2	41502
			80/67	92.4	35151	27822	2.575	13.7	35921	2.380	15.1	44035
			85/71	93.1	37697	28809	2.590	14.6	38467	2.395	16.1	46627
	9.8	11.9	75/63	88.7	33153	26966	2.495	13.3	33923	2.343	14.5	41685
			80/67	89.3	35599	28001	2.504	14.2	36369	2.352	15.5	44263
			85/71	89.8	38202	28993	2.515	15.2	38972	2.363	16.5	46897
85	5.2	3.4	75/63	101.2	31347	26177	2.809	11.2	32117	2.595	12.4	40896
			80/67	102.1	33634	27215	2.829	11.9	34404	2.615	13.2	43291
			85/71	103.1	36003	28191	2.851	12.6	36773	2.637	13.9	45796
	7.3	6.6	75/63	96.6	31986	26455	2.693	11.9	32756	2.498	13.1	41165
			80/67	97.3	34340	27497	2.706	12.7	35110	2.511	14.0	43604
			85/71	98.0	36784	28475	2.721	13.5	37554	2.526	14.9	46205
	9.8	11.9	75/63	93.7	32398	26635	2.623	12.4	33168	2.471	13.4	41346
			80/67	94.2	34802	27683	2.631	13.2	35572	2.479	14.4	43835
			85/71	94.7	37354	28683	2.642	14.1	38124	2.490	15.3	46449
90	5.2	3.4	75/63	106.1	30565	25836	2.957	10.3	31335	2.743	11.4	40580
			80/67	107.0	32804	26883	2.977	11.0	33574	2.763	12.2	42937
			85/71	108.0	35112	27865	2.999	11.7	35882	2.785	12.9	45387
	7.3	6.6	75/63	101.5	31210	26117	2.834	11.0	31980	2.639	12.1	40839
			80/67	102.2	33528	27172	2.847	11.8	34298	2.652	12.9	43247
			85/71	102.9	35936	28166	2.862	12.6	36706	2.667	13.8	45764
	9.8	11.9	75/63	98.6	31612	26292	2.760	11.5	32382	2.608	12.4	41006
			80/67	99.1	33979	27353	2.768	12.3	34749	2.616	13.3	43449
			85/71	99.7	36448	28352	2.779	13.1	37218	2.627	14.2	46009
100	5.2	3.4	75/63	115.9	28938	25126	3.290	8.8	29708	3.076	9.7	40082
			80/67	116.8	31049	26182	3.310	9.4	31819	3.096	10.3	42275
			85/71	117.7	33268	27194	3.334	10.0	34038	3.120	10.9	44612
	7.3	6.6	75/63	111.4	29598	25414	3.150	9.4	30368	2.955	10.3	40223
			80/67	112.0	31797	26481	3.163	10.1	32567	2.968	11.0	42547
			85/71	112.7	34112	27502	3.177	10.7	34882	2.982	11.7	44952
	9.8	11.9	75/63	108.5	30005	25593	3.067	9.8	30775	2.915	10.6	40371
			80/67	109.0	32281	26675	3.075	10.5	33051	2.923	11.3	42725
			85/71	109.5	34631	27690	3.084	11.2	35401	2.932	12.1	45172
110	5.2	3.4	75/63	125.7	27209	24367	3.679	7.4	27978	3.465	8.1	39567
			80/67	126.6	29197	25441	3.701	7.9	29967	3.487	8.6	41684
			85/71	127.4	31298	26476	3.725	8.4	32068	3.511	9.1	43901
	7.3	6.6	75/63	121.2	27894	24668	3.520	7.9	28664	3.325	8.6	39743
			80/67	121.9	29975	25753	3.533	8.5	30745	3.338	9.2	41918
			85/71	122.5	32173	26795	3.547	9.1	32943	3.352	9.8	44203
	9.8	11.9	75/63	118.4	28313	24853	3.426	8.3	29083	3.274	8.9	39860
			80/67	118.9	30450	25943	3.433	8.9	31220	3.281	9.5	42071
			85/71	119.4	32709	26990	3.442	9.5	33479	3.290	10.2	44398

# Heating Capacity Data - Horizontal Unit Size 036

EWT	GPM	WPD	System Heating					ISO System Heating			
			EA	LWT	TOT	kW	COP	TOT	kW	COP	THA
20	5.2	3.4	60	13.5	25407	2.434	3.06	24637	2.220	3.25	17835
			70	13.9	25472	2.707	2.76	24702	2.493	2.90	16917
			80	14.2	25524	3.014	2.48	24754	2.800	2.59	15892
	7.3	6.6	60	15.2	26076	2.445	3.12	25306	2.250	3.29	18483
			70	15.5	26084	2.718	2.81	25314	2.523	2.94	17504
			80	15.8	26081	3.025	2.52	25311	2.830	2.62	16418
	9.8	11.9	60	16.4	26541	2.452	3.17	25771	2.300	3.28	18932
			70	16.6	26504	2.725	2.85	25734	2.573	2.93	17908
			80	16.8	26478	3.033	2.56	25708	2.881	2.61	16788
30	5.2	3.4	60	22.3	28815	2.487	3.39	28045	2.273	3.61	21138
			70	22.7	28747	2.763	3.05	27977	2.549	3.21	20081
			80	23.1	28713	3.078	2.73	27943	2.864	2.86	18903
	7.3	6.6	60	24.3	29655	2.5	3.47	28885	2.305	3.67	21949
			70	24.6	29518	2.777	3.11	28748	2.582	3.26	20811
			80	24.9	29418	3.091	2.79	28648	2.896	2.90	19573
	9.8	11.9	60	25.6	30236	2.509	3.53	29466	2.357	3.66	22515
			70	25.9	30051	2.786	3.16	29281	2.634	3.26	21323
			80	26.1	29901	3.101	2.82	29131	2.949	2.89	20034
40	5.2	3.4	60	31.0	32534	2.544	3.74	31764	2.330	3.99	24743
			70	31.4	32353	2.825	3.35	31583	2.611	3.54	23537
			80	31.9	32201	3.147	3.00	31431	2.933	3.14	22235
	7.3	6.6	60	33.3	33604	2.561	3.84	32834	2.366	4.06	25775
			70	33.6	33315	2.842	3.43	32545	2.647	3.60	24461
			80	34.0	33086	3.165	3.06	32316	2.970	3.19	23067
	9.8	11.9	60	34.9	34326	2.572	3.91	33556	2.420	4.06	26469
			70	35.1	33982	2.854	3.49	33212	2.702	3.60	25103
			80	35.4	33694	3.177	3.11	32924	3.025	3.19	23646
50	5.2	3.4	60	39.5	36610	2.609	4.11	35840	2.395	4.38	28669
			70	40.0	36289	2.896	3.67	35519	2.682	3.88	27306
			80	40.5	35998	3.225	3.27	35228	3.011	3.43	25849
	7.3	6.6	60	42.2	37929	2.631	4.22	37159	2.436	4.47	29926
			70	42.6	37492	2.919	3.76	36722	2.724	3.95	28456
			80	43.0	37120	3.25	3.34	36350	3.055	3.48	26904
	9.8	11.9	60	44.0	38821	2.646	4.30	38051	2.494	4.47	30804
			70	44.3	38312	2.935	3.82	37542	2.783	3.95	29260
			80	44.6	37873	3.266	3.40	37103	3.114	3.49	27604
60	5.2	3.4	60	47.9	41017	2.685	4.47	40247	2.471	4.77	32890
			70	48.5	40598	2.98	3.99	39828	2.766	4.22	31360
			80	49.1	40162	3.318	3.54	39392	3.104	3.72	29753
	7.3	6.6	60	51.0	42629	2.715	4.60	41859	2.520	4.86	34418
			70	51.4	42028	3.009	4.09	41259	2.814	4.29	32766
			80	51.9	41491	3.349	3.63	40721	3.154	3.78	31028
	9.8	11.9	60	53.1	43721	2.735	4.68	42951	2.583	4.87	35464
			70	53.4	43044	3.03	4.16	42274	2.878	4.30	33735
			80	53.8	42446	3.372	3.69	41676	3.220	3.79	31911
70	5.2	3.4	60	56.2	45750	2.774	4.83	44980	2.560	5.15	37388
			70	56.9	45127	3.075	4.30	44357	2.861	4.54	35712
			80	57.5	44630	3.426	3.81	43860	3.212	4.00	33946
	7.3	6.6	60	59.7	47700	2.81	4.97	46930	2.615	5.26	39239
			70	60.2	46899	3.115	4.41	46129	2.920	4.63	37405
			80	60.7	46256	3.467	3.91	45486	3.272	4.07	35453
	9.8	11.9	60	62.1	49009	2.837	5.06	48239	2.685	5.26	40496
			70	62.5	48137	3.144	4.48	47367	2.992	4.64	38539
			80	62.9	47387	3.497	3.97	46617	3.345	4.08	36499
80	5.2	3.4	60	64.4	50833	2.876	5.18	50063	2.662	5.51	42205
			70	65.1	50043	3.19	4.59	49273	2.976	4.85	40298
			80	65.9	49386	3.551	4.07	48616	3.337	4.27	38335
	7.3	6.6	60	68.3	53072	2.926	5.31	52302	2.731	5.61	44349
			70	68.9	52174	3.243	4.71	51404	3.048	4.94	42309
			80	69.5	51346	3.607	4.17	50576	3.412	4.34	40106
	9.8	11.9	60	71.0	54643	2.962	5.40	53873	2.810	5.61	45840
			70	71.5	53624	3.275	4.79	52854	3.123	4.96	43666
			80	71.9	52650	3.645	4.23	51880	3.493	4.35	41352
85	5.2	3.4	60	68.5	53473	2.935	5.33	52703	2.721	5.67	44683
			70	69.2	52639	3.255	4.74	51869	3.041	4.99	42700
			80	70.0	51861	3.622	4.19	51091	3.408	4.39	40609
	7.3	6.6	60	72.6	55907	2.992	5.47	55137	2.797	5.77	46993
			70	73.2	54908	3.309	4.86	54138	3.114	5.09	44851
			80	73.8	53981	3.685	4.29	53211	3.490	4.46	42535
	9.8	11.9	60	75.5	57634	3.034	5.56	56864	2.882	5.78	48568
			70	75.9	56498	3.353	4.93	55728	3.201	5.10	46333
			80	76.4	55407	3.729	4.35	54637	3.577	4.47	43859
90	5.2	3.4	60	72.6	56185	2.999	5.49	55415	2.785	5.83	47214
			70	73.3	55279	3.32	4.88	54509	3.106	5.14	45162
			80	74.1	54392	3.697	4.31	53622	3.483	4.51	42923
	7.3	6.6	60	76.9	58793	3.063	5.62	58023	2.868	5.92	49690
			70	77.5	57692	3.386	4.99	56922	3.191	5.22	47437
			80	78.2	56669	3.769	4.40	55899	3.574	4.58	45006
	9.8	11.9	60	79.9	60650	3.111	5.71	59880	2.959	5.93	51446
			70	80.4	59466	3.438	5.06	58696	3.286	5.23	48991
			80	80.9	58217	3.819	4.46	57447	3.667	4.59	46444

# Cooling Capacity Data – Horizontal Unit Size 042

EWT	GPM	WPD	System Cooling						ISO System Cooling			
			EA	LWT	TOT	SEN	kW	EER	TOT	kW	EER	THR
30	6.0	3.9	75/63	48.1	46422	35264	1.801	25.8	47507	1.498	31.7	52757
			80/67	49.4	49831	36419	1.828	27.3	50917	1.525	33.4	56301
			85/71	50.6	53355	37467	1.863	28.6	54441	1.560	34.9	60007
	8.5	7.8	75/63	42.8	46927	35494	1.668	28.1	48012	1.392	34.5	52814
			80/67	43.7	50434	36672	1.692	29.8	51519	1.416	36.4	56483
			85/71	44.6	54071	37742	1.721	31.4	55156	1.445	38.2	60251
	11.4	14.1	75/63	39.5	47193	35616	1.587	29.7	48279	1.370	35.2	52820
			80/67	40.2	50756	36807	1.608	31.6	51842	1.391	37.3	56535
			85/71	40.9	54453	37889	1.635	33.3	55538	1.418	39.2	60382
40	6.0	3.9	75/63	58.1	45324	34766	2.047	22.1	46410	1.744	26.6	52413
			80/67	59.2	48570	35892	2.071	23.5	49656	1.768	28.1	55812
			85/71	60.5	51989	36945	2.099	24.8	53075	1.796	29.6	59404
	8.5	7.8	75/63	52.8	45933	35042	1.922	23.9	47018	1.646	28.6	52617
			80/67	53.6	49306	36200	1.941	25.4	50391	1.665	30.3	56123
			85/71	54.5	52813	37260	1.962	26.9	53899	1.686	32.0	59780
	11.4	14.1	75/63	49.5	46238	35180	1.845	25.1	47323	1.628	29.1	52699
			80/67	50.2	49697	36363	1.860	26.7	50783	1.643	30.9	56290
			85/71	50.9	53271	37434	1.880	28.3	54357	1.663	32.7	59995
50	6.0	3.9	75/63	67.9	43969	34153	2.293	19.2	45054	1.990	22.6	51902
			80/67	69.1	47107	35285	2.317	20.3	48192	2.014	23.9	55135
			85/71	70.3	50414	36348	2.342	21.5	51500	2.039	25.3	58592
	8.5	7.8	75/63	62.7	44664	34467	2.170	20.6	45749	1.894	24.2	52146
			80/67	63.5	47913	35619	2.187	21.9	48999	1.911	25.6	55492
			85/71	64.4	51326	36693	2.204	23.3	52411	1.928	27.2	59111
	11.4	14.1	75/63	59.5	45064	34647	2.096	21.5	46149	1.879	24.6	52319
			80/67	60.1	48362	35806	2.108	22.9	49448	1.891	26.1	55739
			85/71	60.8	51845	36890	2.122	24.4	52931	1.905	27.8	59327
60	6.0	3.9	75/63	77.7	42472	33481	2.549	16.7	43557	2.246	19.4	51196
			80/67	78.8	45491	34619	2.573	17.7	46576	2.270	20.5	54315
			85/71	80.0	48658	35686	2.599	18.7	49744	2.296	21.7	57661
	8.5	7.8	75/63	72.6	43204	33809	2.424	17.8	44289	2.148	20.6	51520
			80/67	73.4	46338	34968	2.440	19.0	47423	2.164	21.9	54742
			85/71	74.2	49634	36053	2.456	20.2	50720	2.180	23.3	58138
	11.4	14.1	75/63	69.4	43650	34009	2.349	18.6	44736	2.132	21.0	51690
			80/67	70.0	46835	35173	2.361	19.8	47921	2.144	22.4	54995
			85/71	70.7	50207	36269	2.373	21.2	51292	2.156	23.8	58524
70	6.0	3.9	75/63	87.5	40852	32759	2.826	14.5	41937	2.523	16.6	50419
			80/67	88.6	43734	33899	2.850	15.3	44819	2.547	17.6	53474
			85/71	89.7	46778	34982	2.877	16.3	47863	2.574	18.6	56656
	8.5	7.8	75/63	82.4	41628	33104	2.693	15.5	42713	2.417	17.7	50788
			80/67	83.2	44629	34265	2.709	16.5	45714	2.433	18.8	53934
			85/71	84.0	47796	35363	2.726	17.5	48881	2.450	20.0	57232
	11.4	14.1	75/63	79.3	42081	33306	2.615	16.1	43166	2.398	18.0	51005
			80/67	79.9	45151	34480	2.626	17.2	46236	2.409	19.2	54131
			85/71	80.5	48391	35586	2.638	18.3	49476	2.421	20.4	57510
80	6.0	3.9	75/63	97.2	39078	31973	3.131	12.5	40163	2.828	14.2	49635
			80/67	98.3	41864	33140	3.157	13.3	42949	2.854	15.0	52583
			85/71	99.3	44785	34242	3.184	14.1	45871	2.881	15.9	55647
	8.5	7.8	75/63	92.3	39891	32332	2.987	13.4	40977	2.711	15.1	49987
			80/67	93.0	42790	33515	3.003	14.2	43875	2.727	16.1	53041
			85/71	93.8	45832	34631	3.020	15.2	46917	2.744	17.1	56142
	11.4	14.1	75/63	89.2	40368	32544	2.904	13.9	41454	2.687	15.4	50216
			80/67	89.7	43329	33735	2.915	14.9	44414	2.698	16.5	53265
			85/71	90.3	46443	34858	2.927	15.9	47529	2.710	17.5	56462
85	6.0	3.9	75/63	102.1	38159	31567	3.298	11.6	39244	2.995	13.1	49227
			80/67	103.1	40875	32740	3.324	12.3	41961	3.021	13.9	52132
			85/71	104.2	43710	33846	3.352	13.0	44796	3.049	14.7	55119
	8.5	7.8	75/63	97.1	38985	31932	3.145	12.4	40070	2.869	14.0	49608
			80/67	97.9	41832	33126	3.163	13.2	42917	2.887	14.9	52540
			85/71	98.7	44805	34249	3.180	14.1	45890	2.904	15.8	55617
	11.4	14.1	75/63	94.1	39471	32146	3.061	12.9	40556	2.844	14.3	49793
			80/67	94.7	42374	33346	3.071	13.8	43459	2.854	15.2	52801
			85/71	95.2	45425	34480	3.083	14.7	46511	2.866	16.2	55931
90	6.0	3.9	75/63	107.0	37215	31153	3.476	10.7	38300	3.173	12.1	48841
			80/67	108.0	39891	32342	3.503	11.4	40977	3.200	12.8	51719
			85/71	109.0	42642	33452	3.531	12.1	43727	3.228	13.5	54593
	8.5	7.8	75/63	102.1	38056	31522	3.317	11.5	39141	3.041	12.9	49183
			80/67	102.8	40837	32724	3.333	12.3	41922	3.057	13.7	52088
			85/71	103.5	43716	33848	3.351	13.0	44802	3.075	14.6	55096
	11.4	14.1	75/63	99.0	38547	31739	3.226	11.9	39632	3.009	13.2	49418
			80/67	99.5	41388	32947	3.233	12.8	42473	3.016	14.1	52361
			85/71	100.1	44386	34095	3.248	13.7	45472	3.031	15.0	55404
100	6.0	3.9	75/63	116.8	35270	30299	3.873	9.1	36355	3.570	10.2	48225
			80/67	117.7	37816	31509	3.900	9.7	38901	3.597	10.8	50852
			85/71	118.7	40413	32633	3.931	10.3	41498	3.628	11.4	53630
	8.5	7.8	75/63	111.9	36127	30675	3.693	9.8	37212	3.417	10.9	48476
			80/67	112.6	38784	31897	3.710	10.5	39869	3.434	11.6	51222
			85/71	113.3	41515	33038	3.729	11.1	42600	3.453	12.3	54091
	11.4	14.1	75/63	108.9	36628	30895	3.592	10.2	37713	3.375	11.2	48632
			80/67	109.4	39349	32125	3.603	10.9	40435	3.386	11.9	51450
			85/71	110.0	42157	33273	3.615	11.7	43242	3.398	12.7	54372
110	6.0	3.9	75/63	126.6	32317	29400	4.330	7.7	34303	4.027	8.5	47585
			80/67	127.5	35582	30614	4.359	8.2	36668	4.056	9.0	50111
			85/71	128.4	38059	31774	4.392	8.7	39144	4.089	9.6	52739
	8.5	7.8	75/63	121.8	34103	29788	4.127	8.3	35189	3.851	9.1	47828
			80/67	122.4	36591	31017	4.144	8.8	37676	3.868	9.7	50433
			85/71	123.1	39198	32189	4.164	9.4	40284	3.888	10.4	53154
	11.4	14.1	75/63	118.8	34618	30014	4.013	8.6	35703	3.796	9.4	47980
			80/67	119.3	37174	31252	4.024	9.2	38259	3.807	10.0	50632
			85/71	119.8	39858	32430	4.036	9.9	40943	3.819	10.7	53407

# Heating Capacity Data – Horizontal Unit Size 042

EWT	GPM	WPD	System Heating					ISO System Heating			
			EA	LWT	TOT	kW	COP	TOT	kW	COP	THA
20	6.0	3.9	60	13.3	29071	2.677	3.18	27986	2.374	3.45	20983
			70	13.6	29120	2.979	2.86	28035	2.676	3.07	19959
			80	14.0	29164	3.317	2.57	28079	3.014	2.73	18806
	8.5	7.8	60	15.1	29881	2.69	3.25	28795	2.414	3.49	21765
			70	15.3	29863	2.993	2.92	28778	2.717	3.10	20669
			80	15.6	29845	3.332	2.62	28759	3.056	2.76	19483
	11.4	14.1	60	16.2	30414	2.699	3.30	29329	2.482	3.46	22281
			70	16.4	30350	3.002	2.96	29265	2.785	3.08	21139
			80	16.6	30314	3.342	2.66	29229	3.125	2.74	19911
30	6.0	3.9	60	22.0	33193	2.745	3.54	32108	2.442	3.85	24972
			70	22.4	33091	3.053	3.17	32006	2.750	3.41	23767
			80	22.8	33038	3.401	2.84	31953	3.098	3.02	22483
	8.5	7.8	60	24.1	34217	2.761	3.63	33132	2.485	3.90	25955
			70	24.4	34036	3.07	3.25	32951	2.794	3.45	24674
			80	24.7	33906	3.419	2.90	32820	3.143	3.06	23304
	11.4	14.1	60	25.5	34899	2.773	3.69	33814	2.556	3.87	26617
			70	25.7	34663	3.083	3.29	33578	2.866	3.43	25272
			80	26.0	34477	3.432	2.94	33392	3.215	3.04	23846
40	6.0	3.9	60	30.5	37713	2.819	3.92	36628	2.516	4.26	29314
			70	31.0	37454	3.135	3.50	36369	2.832	3.76	27947
			80	31.5	37256	3.492	3.12	36171	3.189	3.32	26495
	8.5	7.8	60	33.0	38988	2.84	4.02	37903	2.564	4.33	30570
			70	33.4	38635	3.157	3.58	37550	2.881	3.82	29076
			80	33.7	38345	3.516	3.19	37260	3.240	3.37	27514
	11.4	14.1	60	34.7	39626	2.849	4.07	38541	2.632	4.29	31409
			70	34.9	39421	3.172	3.64	38336	2.955	3.80	29829
			80	35.2	39064	3.531	3.24	37979	3.314	3.36	28194
50	6.0	3.9	60	39.0	42357	2.896	4.28	41272	2.593	4.66	34066
			70	39.5	42185	3.226	3.83	41099	2.923	4.12	32462
			80	40.0	41821	3.592	3.41	40736	3.289	3.63	30814
	8.5	7.8	60	41.9	44165	2.929	4.42	43080	2.653	4.76	35555
			70	42.3	43649	3.254	3.93	42563	2.978	4.19	33862
			80	42.7	43183	3.623	3.49	42098	3.347	3.68	32100
	11.4	14.1	60	43.8	45000	2.942	4.48	43915	2.725	4.72	36580
			70	44.1	44613	3.273	3.99	43528	3.056	4.17	34802
			80	44.4	44069	3.643	3.54	42984	3.426	3.67	32923
60	6.0	3.9	60	47.3	47816	2.994	4.68	46730	2.691	5.09	39037
			70	47.9	47284	3.327	4.16	46198	3.024	4.47	37287
			80	48.5	46752	3.705	3.69	45666	3.402	3.93	35451
	8.5	7.8	60	50.6	49750	3.029	4.81	48665	2.753	5.18	40874
			70	51.1	49020	3.363	4.27	47935	3.087	4.55	38973
			80	51.5	48393	3.744	3.78	47308	3.468	3.99	36985
	11.4	14.1	60	52.8	51018	3.053	4.89	49933	2.836	5.16	42104
			70	53.2	50212	3.388	4.34	49127	3.171	4.54	40099
			80	53.5	49467	3.769	3.84	48382	3.552	3.99	38009
70	6.0	3.9	60	55.6	53390	3.095	5.05	52305	2.792	5.49	44355
			70	56.2	52658	3.441	4.48	51573	3.138	4.81	42396
			80	56.9	52006	3.833	3.97	50921	3.530	4.22	40355
	8.5	7.8	60	59.3	55698	3.14	5.19	54613	2.864	5.58	46530
			70	59.8	54727	3.486	4.60	53641	3.210	4.89	44409
			80	60.3	53912	3.88	4.07	52827	3.604	4.29	42151
	11.4	14.1	60	61.8	57202	3.17	5.28	56117	2.953	5.56	47992
			70	62.2	56151	3.518	4.67	55065	3.301	4.88	45717
			80	62.6	55208	3.913	4.13	54123	3.696	4.29	43355
80	6.0	3.9	60	63.8	59268	3.212	5.40	58183	2.909	5.86	49900
			70	64.5	58315	3.567	4.79	57229	3.264	5.13	47723
			80	65.2	57455	3.972	4.24	56370	3.669	4.50	45434
	8.5	7.8	60	67.9	61669	3.261	5.54	60584	2.985	5.94	52505
			70	68.5	60817	3.622	4.92	59731	3.346	5.23	50105
			80	69.1	59790	4.035	4.34	58705	3.759	4.57	47546
	11.4	14.1	60	70.7	63454	3.299	5.63	62368	3.082	5.93	54204
			70	71.1	62463	3.662	4.99	61378	3.445	5.22	51645
			80	71.6	61226	4.073	4.40	60141	3.856	4.57	48946
85	6.0	3.9	60	67.8	62014	3.268	5.56	60929	2.965	6.02	52832
			70	68.5	61221	3.632	4.94	60136	3.329	5.29	50513
			80	69.3	60274	4.047	4.36	59188	3.744	4.63	48047
	8.5	7.8	60	72.2	65129	3.337	5.71	64043	3.061	6.13	55538
			70	72.8	63913	3.698	5.06	62828	3.422	5.38	53003
			80	73.4	62740	4.116	4.46	61655	3.840	4.70	50312
	11.4	14.1	60	75.2	67059	3.381	5.81	65974	3.164	6.11	57293
			70	75.6	65645	3.741	5.14	64560	3.524	5.36	54675
			80	76.1	64339	4.161	4.53	63253	3.944	4.70	51846
90	6.0	3.9	60	71.8	65402	3.344	5.73	64317	3.041	6.19	55696
			70	72.6	64256	3.706	5.08	63171	3.403	5.44	53290
			80	73.5	63141	4.127	4.48	62056	3.824	4.75	50695
	8.5	7.8	60	76.5	68420	3.412	5.87	67335	3.136	6.29	58591
			70	77.1	67059	3.777	5.20	65974	3.501	5.52	55955
			80	77.8	65755	4.202	4.58	64669	3.926	4.82	53124
	11.4	14.1	60	79.6	70062	3.448	5.95	68976	3.231	6.25	60595
			70	80.1	69037	3.829	5.28	67951	3.612	5.51	57705
			80	80.6	67503	4.247	4.65	66418	4.030	4.83	54783

# Cooling Capacity Data – Horizontal Unit Size 048

EWT	GPM	WPD	System Cooling						ISO System Cooling			
			EA	LWT	TOT	SEN	kW	EER	TOT	kW	EER	THR
30	6.9	5.2	75/63	48.3	51345	40524	2.158	23.8	52607	1.811	29.0	58690
			80/67	49.6	55063	41805	2.197	25.1	56325	1.850	30.4	62650
			85/71	50.8	58989	42999	2.236	26.4	60251	1.889	31.9	66723
	9.8	10.4	75/63	42.9	52009	40842	2.011	25.9	53271	1.706	31.2	58898
			80/67	43.8	55866	42159	2.044	27.3	57128	1.739	32.9	63014
			85/71	44.8	59966	43393	2.078	28.9	61228	1.773	34.5	67229
	13.0	18.3	75/63	39.8	52366	41013	1.924	27.2	53628	1.704	31.5	58990
			80/67	40.5	56327	42362	1.955	28.8	57588	1.735	33.2	63179
			85/71	41.2	60499	43608	1.985	30.5	61761	1.765	35.0	67488
40	6.9	5.2	75/63	58.2	49973	39870	2.422	20.6	51235	2.075	24.7	58117
			80/67	59.4	53552	41143	2.456	21.8	54814	2.109	26.0	61904
			85/71	60.6	57267	42309	2.491	23.0	58529	2.144	27.3	65788
	9.8	10.4	75/63	52.9	50707	40219	2.286	22.2	51969	1.981	26.2	58474
			80/67	53.7	54446	41534	2.314	23.5	55708	2.009	27.7	62311
			85/71	54.6	58284	42715	2.344	24.9	59546	2.039	29.2	66327
	13.0	18.3	75/63	49.7	51108	40410	2.207	23.2	52370	1.987	26.4	58636
			80/67	50.4	54844	41709	2.231	24.6	56106	2.011	27.9	62572
			85/71	51.1	58859	42947	2.256	26.1	60121	2.036	29.5	66647
50	6.9	5.2	75/63	68.0	48435	39141	2.686	18.0	49697	2.339	21.2	57459
			80/67	69.1	51824	40392	2.715	19.1	53086	2.368	22.4	60987
			85/71	70.3	55415	41572	2.747	20.2	56677	2.400	23.6	64692
	9.8	10.4	75/63	62.8	49227	39517	2.553	19.3	50489	2.248	22.5	57839
			80/67	63.6	52802	40816	2.577	20.5	54063	2.272	23.8	61490
			85/71	64.4	56473	41992	2.603	21.7	57734	2.298	25.1	65337
	13.0	18.3	75/63	59.7	49645	39715	2.476	20.1	50907	2.256	22.6	58035
			80/67	60.3	53302	41035	2.496	21.4	54564	2.276	24.0	61746
			85/71	60.9	57072	42231	2.519	22.7	58334	2.299	25.4	65690
60	6.9	5.2	75/63	77.8	46775	38360	2.960	15.8	48036	2.613	18.4	56535
			80/67	78.9	50034	39619	2.988	16.7	51296	2.641	19.4	60008
			85/71	80.0	53450	40797	3.016	17.7	54712	2.669	20.5	63547
	9.8	10.4	75/63	72.6	47601	38748	2.822	16.9	48863	2.517	19.4	56994
			80/67	73.4	50994	40033	2.843	17.9	52256	2.538	20.6	60515
			85/71	74.2	54549	41230	2.865	19.0	55811	2.560	21.8	64156
	13.0	18.3	75/63	69.5	48070	38970	2.746	17.5	49332	2.526	19.5	57215
			80/67	70.1	51516	40259	2.763	18.6	52778	2.543	20.8	60813
			85/71	70.8	55158	41471	2.782	19.8	56420	2.562	22.0	64529
70	6.9	5.2	75/63	87.6	44986	37524	3.256	13.8	46248	2.909	15.9	55735
			80/67	88.6	48135	38804	3.282	14.7	49397	2.935	16.8	58944
			85/71	89.7	51387	39988	3.310	15.5	52649	2.963	17.8	62386
	9.8	10.4	75/63	82.4	45847	37927	3.110	14.7	47109	2.805	16.8	56119
			80/67	83.2	49117	39225	3.128	15.7	50379	2.823	17.8	59447
			85/71	84.0	52508	40426	3.148	16.7	53769	2.843	18.9	62962
	13.0	18.3	75/63	79.4	46351	38162	3.030	15.3	47613	2.810	16.9	56359
			80/67	80.0	49670	39462	3.043	16.3	50932	2.823	18.0	59769
			85/71	80.6	53135	40672	3.060	17.4	54397	2.840	19.2	63343
80	6.9	5.2	75/63	97.3	43094	36646	3.589	12.0	44356	3.242	13.7	54798
			80/67	98.3	46083	37930	3.618	12.7	47345	3.271	14.5	57951
			85/71	99.3	49162	39122	3.645	13.5	50424	3.298	15.3	61155
	9.8	10.4	75/63	92.3	44002	37068	3.428	12.8	45264	3.123	14.5	55210
			80/67	93.0	47136	38378	3.446	13.7	48398	3.141	15.4	58433
			85/71	93.7	50371	39592	3.464	14.5	51633	3.159	16.3	61866
	13.0	18.3	75/63	89.3	44490	37294	3.340	13.3	45752	3.120	14.7	55419
			80/67	89.8	47701	38619	3.352	14.2	48962	3.132	15.6	58684
			85/71	90.4	51009	39840	3.367	15.1	52271	3.147	16.6	62167
85	6.9	5.2	75/63	102.2	42111	36193	3.774	11.2	43373	3.427	12.7	54369
			80/67	103.2	45015	37477	3.804	11.8	46277	3.457	13.4	57501
			85/71	104.2	48070	38699	3.831	12.5	49332	3.484	14.2	60661
	9.8	10.4	75/63	97.2	43023	36614	3.602	11.9	44285	3.297	13.4	54753
			80/67	97.9	46063	37921	3.622	12.7	47325	3.317	14.3	57972
			85/71	98.6	49198	39136	3.638	13.5	50460	3.333	15.1	61229
	13.0	18.3	75/63	94.2	43547	36857	3.510	12.4	44809	3.290	13.6	54996
			80/67	94.8	46640	38167	3.523	13.2	47902	3.303	14.5	58202
			85/71	95.3	49926	39419	3.535	14.1	51188	3.315	15.4	61571
90	6.9	5.2	75/63	107.1	41100	35726	3.974	10.3	42362	3.627	11.7	53979
			80/67	108.0	43945	37026	4.003	11.0	45207	3.656	12.4	57021
			85/71	109.0	46956	38269	4.033	11.6	48218	3.686	13.1	60103
	9.8	10.4	75/63	102.1	42026	36153	3.790	11.1	43288	3.485	12.4	54335
			80/67	102.8	44992	37467	3.809	11.8	46254	3.504	13.2	57481
			85/71	103.5	48101	38711	3.826	12.6	49363	3.521	14.0	60661
	13.0	18.3	75/63	99.2	42542	36391	3.692	11.5	43804	3.472	12.6	54552
			80/67	99.7	45618	37732	3.705	12.3	46880	3.485	13.5	57703
			85/71	100.2	48738	38958	3.716	13.1	50000	3.496	14.3	61028
100	6.9	5.2	75/63	116.9	38999	34760	4.426	8.8	40261	4.079	9.9	53219
			80/67	117.8	41699	36079	4.455	9.4	42961	4.108	10.5	56135
			85/71	118.7	44586	37358	4.486	9.9	45848	4.139	11.1	59107
	9.8	10.4	75/63	111.9	39955	35199	4.214	9.5	41217	3.909	10.5	53539
			80/67	112.6	42777	36533	4.231	10.1	44039	3.926	11.2	56521
			85/71	113.3	45774	37813	4.249	10.8	47036	3.944	11.9	59579
	13.0	18.3	75/63	109.0	40485	35443	4.101	9.9	41747	3.881	10.8	53732
			80/67	109.5	43374	36784	4.113	10.5	44636	3.893	11.5	56752
			85/71	110.1	46435	38068	4.124	11.3	47697	3.904	12.2	59882
110	6.9	5.2	75/63	126.7	36781	33743	4.963	7.4	38042	4.616	8.2	52720
			80/67	127.6	39390	35109	4.990	7.9	40652	4.643	8.8	55400
			85/71	128.5	42048	36386	5.020	8.4	43310	4.673	9.3	58235
	9.8	10.4	75/63	121.8	37773	34197	4.714	8.0	39035	4.409	8.9	52866
			80/67	122.5	40456	35556	4.730	8.6	41717	4.425	9.4	55731
			85/71	123.1	43295	36863	4.747	9.1	44556	4.442	10.0	58647
	13.0	18.3	75/63	118.9	38322	34449	4.583	8.4	39584	4.363	9.1	53026
			80/67	119.4	41068	35813	4.593	8.9	42330	4.373	9.7	55924
			85/71	119.9	43980	37125	4.603	9.6	45241	4.383	10.3	58892

# Heating Capacity Data – Horizontal Unit Size 048

EWT	GPM	WPD	System Heating					ISO System Heating				
			EA	LWT	TOT	kW	COP	TOT	kW	COP	THA	
20	6.9	5.2	60	13.4	33109	3.151	3.08	31847	2.804	3.33	23511	
			70	13.8	33254	3.521	2.77	31992	3.174	2.95	22365	
			80	14.1	33390	3.952	2.47	32129	3.605	2.61	20971	
	9.8	10.4	60	15.2	33966	3.164	3.14	32704	2.859	3.35	24337	
			70	15.5	34044	3.534	2.82	32782	3.229	2.97	23113	
			80	15.7	34113	3.964	2.52	32851	3.659	2.63	21665	
	13.0	18.3	60	16.3	34511	3.172	3.19	33249	2.952	3.30	24868	
			70	16.5	34544	3.541	2.86	33282	3.321	2.93	23596	
			80	16.7	34566	3.971	2.55	33305	3.751	2.60	22103	
30	6.9	5.2	60	22.2	37589	3.221	3.42	36327	2.874	3.70	27839	
			70	22.6	37567	3.592	3.06	36305	3.245	3.28	26520	
			80	23.0	37586	4.025	2.73	36324	3.678	2.89	25023	
	9.8	10.4	60	24.3	38671	3.239	3.50	37409	2.934	3.73	28890	
			70	24.6	38572	3.61	3.13	37310	3.305	3.31	27491	
			80	24.9	38503	4.043	2.79	37241	3.738	2.92	25886	
	13.0	18.3	60	25.6	39354	3.25	3.55	38092	3.030	3.68	29565	
			70	25.8	39202	3.621	3.17	37940	3.401	3.27	28084	
			80	26.1	39081	4.054	2.82	37819	3.834	2.89	26437	
40	6.9	5.2	60	30.8	42512	3.305	3.77	41250	2.958	4.08	32542	
			70	31.3	42305	3.679	3.37	41044	3.332	3.61	31041	
			80	31.7	42198	4.118	3.00	40936	3.771	3.18	29394	
	9.8	10.4	60	33.3	43835	3.329	3.86	42573	3.024	4.12	33817	
			70	33.6	43545	3.703	3.44	42283	3.398	3.64	32244	
			80	34.0	43334	4.143	3.06	42072	3.838	3.21	30480	
	13.0	18.3	60	34.8	44677	3.344	3.91	43415	3.124	4.07	34654	
			70	35.1	44330	3.719	3.49	43068	3.499	3.60	32997	
			80	35.3	44053	4.159	3.10	42791	3.939	3.18	31171	
50	6.9	5.2	60	39.4	47769	3.401	4.11	46507	3.054	4.46	37598	
			70	39.9	47428	3.781	3.67	46166	3.434	3.94	35931	
			80	40.4	47192	4.228	3.27	45930	3.881	3.47	34106	
	9.8	10.4	60	42.2	49427	3.432	4.22	48165	3.127	4.51	39151	
			70	42.6	48912	3.811	3.76	47650	3.506	3.98	37406	
			80	43.0	48548	4.259	3.34	47286	3.954	3.50	35437	
	13.0	18.3	60	44.0	50449	3.451	4.28	49187	3.231	4.46	40170	
			70	44.3	49890	3.832	3.81	48628	3.612	3.94	38291	
			80	44.6	49467	4.28	3.38	48205	4.060	3.48	36282	
60	6.9	5.2	60	47.8	53448	3.505	4.47	52186	3.158	4.84	43048	
			70	48.4	52929	3.896	3.98	51667	3.549	4.26	41135	
			80	48.9	52514	4.352	3.53	51252	4.005	3.75	39145	
	9.8	10.4	60	51.0	55132	3.536	4.57	53870	3.231	4.88	44943	
			70	51.5	54779	3.936	4.08	53517	3.631	4.32	42884	
			80	51.9	54230	4.393	3.61	52968	4.088	3.79	40735	
	13.0	18.3	60	53.1	56689	3.569	4.65	55427	3.349	4.85	46118	
			70	53.4	55931	3.961	4.13	54670	3.741	4.28	43983	
			80	53.7	55294	4.419	3.66	54033	4.199	3.77	41743	
70	6.9	5.2	60	56.2	59499	3.625	4.81	58237	3.278	5.20	48771	
			70	56.8	58770	4.019	4.28	57509	3.672	4.59	46714	
			80	57.4	58226	4.492	3.80	56964	4.145	4.02	44460	
	9.8	10.4	60	59.8	61804	3.671	4.93	60542	3.366	5.27	50990	
			70	60.3	60941	4.067	4.39	59679	3.762	4.65	48757	
			80	60.7	60251	4.543	3.88	58989	4.238	4.08	46378	
	13.0	18.3	60	62.1	63292	3.701	5.01	62030	3.481	5.22	52422	
			70	62.5	62373	4.1	4.45	61111	3.880	4.61	50052	
			80	62.8	61504	4.575	3.94	60242	4.355	4.05	47559	
80	6.9	5.2	60	64.4	65826	3.753	5.14	64565	3.406	5.55	54806	
			70	65.1	65010	4.161	4.57	63748	3.814	4.89	52519	
			80	65.8	64203	4.644	4.05	62941	4.297	4.29	50072	
	9.8	10.4	60	68.5	68537	3.809	5.27	67275	3.504	5.62	57448	
			70	69.0	67502	4.218	4.69	66240	3.913	4.96	54900	
			80	69.5	66591	4.7	4.15	65329	4.395	4.35	52288	
	13.0	18.3	60	71.1	70456	3.851	5.36	69194	3.631	5.58	59060	
			70	71.5	69113	4.256	4.75	67852	4.036	4.92	56431	
			80	71.9	68089	4.74	4.21	66827	4.520	4.33	53664	
85	6.9	5.2	60	68.5	69115	3.822	5.30	67854	3.475	5.72	57930	
			70	69.2	68208	4.236	4.71	66946	3.889	5.04	55512	
			80	69.9	67356	4.72	4.18	66094	4.373	4.43	52975	
	9.8	10.4	60	72.8	71515	3.868	5.41	70254	3.563	5.77	60818	
			70	73.4	70872	4.298	4.83	69610	3.993	5.11	58065	
			80	73.9	69853	4.786	4.27	68591	4.481	4.48	55318	
	13.0	18.3	60	75.6	73897	3.922	5.52	72635	3.702	5.75	62472	
			70	76.0	72591	4.338	4.90	71330	4.118	5.07	59714	
			80	76.4	71444	4.829	4.33	70182	4.609	4.46	56806	
90	6.9	5.2	60	72.6	72491	3.893	5.45	71230	3.546	5.88	61108	
			70	73.3	71431	4.311	4.85	70169	3.964	5.18	58566	
			80	74.1	70516	4.804	4.30	69254	4.457	4.55	55900	
	9.8	10.4	60	77.2	75643	3.959	5.59	74381	3.654	5.96	64086	
			70	77.7	74370	4.382	4.97	73108	4.077	5.25	61286	
			80	78.3	73168	4.875	4.39	71906	4.570	4.61	58393	
	13.0	18.3	60	80.0	77574	4	5.68	76312	3.780	5.91	65957	
			70	80.5	76193	4.425	5.04	74931	4.205	5.22	63056	
			80	80.9	74857	4.921	4.45	73595	4.701	4.58	59983	

# Cooling Capacity Data – Horizontal Unit Size 060

EWT	GPM	WPD	System Cooling						ISO System Cooling			
			EA	LWT	TOT	SEN	kW	EER	TOT	kW	EER	THR
30	8.6	7.2	75/63	48.1	66319	50647	2.458	27.0	67575	2.129	31.7	74928
			80/67	49.4	71157	52275	2.542	28.0	72414	2.213	32.7	80153
			85/71	50.7	76165	53754	2.632	28.9	77421	2.303	33.6	85539
	12.2	14.4	75/63	42.8	66990	50956	2.256	29.7	68247	1.998	34.2	74941
			80/67	43.7	71966	52618	2.340	30.8	73222	2.082	35.2	80332
			85/71	44.6	77157	54139	2.428	31.8	78413	2.170	36.1	85856
	16.3	25.7	75/63	39.6	67338	51117	2.139	31.5	68595	2.034	33.7	74904
			80/67	40.3	72391	52799	2.223	32.6	73647	2.118	34.8	80392
			85/71	41.0	77658	54334	2.314	33.6	78915	2.209	35.7	86022
40	8.6	7.2	75/63	58.1	64675	49891	2.874	22.5	65932	2.545	25.9	74585
			80/67	59.3	69222	51458	2.943	23.5	70478	2.614	27.0	79510
			85/71	60.5	74029	52929	3.017	24.5	75286	2.688	28.0	84585
	12.2	14.4	75/63	52.8	65424	50235	2.691	24.3	66681	2.433	27.4	74786
			80/67	53.7	70195	51869	2.757	25.5	71451	2.499	28.6	79867
			85/71	54.6	75121	53350	2.829	26.6	76378	2.571	29.7	85127
	16.3	25.7	75/63	49.6	65845	50428	2.585	25.5	67102	2.480	27.1	74864
			80/67	50.2	70658	52064	2.650	26.7	71915	2.545	28.3	80002
			85/71	50.9	75694	53572	2.723	27.8	76951	2.618	29.4	85339
50	8.6	7.2	75/63	68.0	62665	48973	3.267	19.2	63922	2.938	21.8	73889
			80/67	69.1	67067	50554	3.325	20.2	68323	2.996	22.8	78510
			85/71	70.3	71636	52012	3.392	21.1	72893	3.063	23.8	83389
	12.2	14.4	75/63	62.7	63599	49399	3.094	20.6	64856	2.836	22.9	74233
			80/67	63.5	68100	50987	3.148	21.6	69357	2.890	24.0	79099
			85/71	64.4	72842	52473	3.210	22.7	74098	2.952	25.1	84046
	16.3	25.7	75/63	59.5	64082	49620	2.997	21.4	65339	2.892	22.6	74403
			80/67	60.2	68650	51217	3.049	22.5	69907	2.944	23.7	79211
			85/71	60.8	73474	52715	3.110	23.6	74730	3.005	24.9	84361
60	8.6	7.2	75/63	77.8	60505	47993	3.654	16.6	61762	3.325	18.6	72890
			80/67	78.8	64676	49558	3.706	17.5	65933	3.377	19.5	77304
			85/71	80.0	69077	51037	3.766	18.3	70333	3.437	20.5	82004
	12.2	14.4	75/63	72.6	61478	48433	3.483	17.7	62734	3.225	19.5	73372
			80/67	73.4	65804	50027	3.529	18.6	67061	3.271	20.5	77891
			85/71	74.2	70348	51520	3.584	19.6	71604	3.326	21.5	82719
	16.3	25.7	75/63	69.5	62009	48674	3.390	18.3	63265	3.285	19.3	73604
			80/67	70.1	66403	50276	3.433	19.3	67660	3.328	20.3	78190
			85/71	70.7	71020	51776	3.486	20.4	72276	3.381	21.4	83089
70	8.6	7.2	75/63	87.5	58134	46925	4.048	14.4	59390	3.719	16.0	71807
			80/67	88.6	62119	48500	4.097	15.2	63375	3.768	16.8	75980
			85/71	89.7	66327	49998	4.155	16.0	67583	3.826	17.7	80475
	12.2	14.4	75/63	82.5	59179	47394	3.875	15.3	60435	3.617	16.7	72342
			80/67	83.2	63310	48992	3.917	16.2	64567	3.659	17.6	76653
			85/71	84.0	67657	50500	3.967	17.1	68914	3.709	18.6	81234
	16.3	25.7	75/63	79.4	59735	47645	3.781	15.8	60992	3.676	16.6	72612
			80/67	79.9	63944	49255	3.819	16.7	65201	3.714	17.6	76911
			85/71	80.5	68365	50767	3.867	17.7	69622	3.762	18.5	81636
80	8.6	7.2	75/63	97.2	55587	45785	4.464	12.5	56843	4.135	13.7	70522
			80/67	98.3	59419	47392	4.517	13.2	60675	4.188	14.5	74642
			85/71	99.3	63423	48909	4.575	13.9	64679	4.246	15.2	78899
	12.2	14.4	75/63	92.3	56683	46275	4.284	13.2	57940	4.026	14.4	71070
			80/67	93.0	60645	47895	4.325	14.0	61901	4.067	15.2	75278
			85/71	93.7	64803	49426	4.374	14.8	66059	4.116	16.0	79668
	16.3	25.7	75/63	89.2	57328	46563	4.185	13.7	58585	4.080	14.4	71365
			80/67	89.8	61310	48168	4.223	14.5	62567	4.118	15.2	75626
			85/71	90.3	65539	49702	4.268	15.4	66795	4.163	16.0	80081
85	8.6	7.2	75/63	102.1	54264	45195	4.692	11.6	55520	4.363	12.7	69916
			80/67	103.1	57992	46809	4.744	12.2	59248	4.415	13.4	73966
			85/71	104.1	61932	48352	4.801	12.9	63189	4.472	14.1	78122
	12.2	14.4	75/63	97.2	55382	45693	4.501	12.3	56639	4.243	13.3	70472
			80/67	97.8	59262	47327	4.540	13.1	60518	4.282	14.1	74498
			85/71	98.6	63323	48872	4.590	13.8	64579	4.332	14.9	78816
	16.3	25.7	75/63	94.1	55996	45967	4.398	12.7	57253	4.293	13.3	70740
			80/67	94.7	59934	47604	4.436	13.5	61191	4.331	14.1	74930
			85/71	95.2	64068	49150	4.481	14.3	65324	4.376	14.9	79288
90	8.6	7.2	75/63	107.0	52909	44593	4.931	10.7	54166	4.602	11.8	69301
			80/67	108.0	56566	46229	4.984	11.3	57822	4.655	12.4	73267
			85/71	109.0	60336	47759	5.043	12.0	61592	4.714	13.1	77347
	12.2	14.4	75/63	102.1	54048	45099	4.730	11.4	55305	4.472	12.4	69819
			80/67	102.8	57833	46744	4.772	12.1	59089	4.514	13.1	73887
			85/71	103.5	61806	48305	4.820	12.8	63062	4.562	13.8	78010
	16.3	25.7	75/63	99.1	54673	45377	4.622	11.8	55930	4.517	12.4	70079
			80/67	98.0	59067	47248	4.576	12.9	60323	4.471	13.5	75012
			85/71	98.5	63096	48787	4.621	13.7	64352	4.516	14.2	79246
100	8.6	7.2	75/63	116.8	50108	43353	5.461	9.2	51364	5.132	10.0	68234
			80/67	117.7	53580	45017	5.515	9.7	54836	5.186	10.6	71892
			85/71	118.6	57143	46577	5.577	10.2	58400	5.248	11.1	75762
	12.2	14.4	75/63	111.9	51286	43874	5.233	9.8	52542	4.975	10.6	68708
			80/67	112.5	54885	45546	5.276	10.4	56142	5.018	11.2	72455
			85/71	113.2	58604	47117	5.326	11.0	59861	5.068	11.8	76435
	16.3	25.7	75/63	108.9	51930	44159	5.110	10.2	53187	5.005	10.6	68862
			80/67	109.4	55603	45838	5.149	10.8	56860	5.044	11.3	72729
			85/71	109.9	59394	47410	5.195	11.4	60651	5.090	11.9	76815
110	8.6	7.2	75/63	126.5	47159	42049	6.074	7.8	48415	5.745	8.4	67172
			80/67	127.4	50388	43725	6.132	8.2	51644	5.803	8.9	70675
			85/71	128.3	53772	45332	6.198	8.7	55028	5.869	9.4	74341
	12.2	14.4	75/63	121.7	48391	42594	5.810	8.3	49647	5.552	8.9	67562
			80/67	122.3	51759	44280	5.856	8.8	53015	5.598	9.5	71178
			85/71	123.0	55296	45895	5.910	9.4	56552	5.652	10.0	74956
	16.3	25.7	75/63	118.8	49068	42893	5.670	8.7	50324	5.565	9.0	67812
			80/67	119.3	52546	44598	5.712	9.2	53802	5.607	9.6	71468
			85/71	119.8	56115	46196	5.760	9.7	57372	5.655	10.1	75307



# Heating Capacity Data – Horizontal Unit Size 060

EWT	GPM	WPD	System Heating				ISO System Heating				
			EA	LWT	TOT	kW	COP	TOT	kW	COP	THA
20	8.6	7.2	60	13.3	41999	3.836	3.21	40742	3.507	3.40	30333
			70	13.6	42068	4.271	2.88	40812	3.942	3.03	28837
			80	14.0	42008	4.737	2.60	40752	4.408	2.71	27159
	12.2	14.4	60	15.1	43108	3.857	3.27	41851	3.599	3.40	31382
			70	15.3	43094	4.291	2.94	41838	4.033	3.04	29812
			80	15.6	42948	4.758	2.64	41692	4.500	2.71	28046
	16.3	25.7	60	16.2	43825	3.87	3.32	42569	3.765	3.31	32071
			70	16.4	43754	4.304	2.98	42497	4.199	2.96	30441
			80	16.6	43555	4.771	2.67	42298	4.666	2.65	28616
30	8.6	7.2	60	22.0	47758	3.94	3.55	46502	3.611	3.77	35869
			70	22.4	47664	4.379	3.19	46408	4.050	3.36	34193
			80	22.8	47489	4.855	2.86	46232	4.526	2.99	32335
	12.2	14.4	60	24.2	49158	3.965	3.63	47901	3.707	3.78	37202
			70	24.4	48921	4.402	3.25	47665	4.144	3.37	35418
			80	24.7	48648	4.879	2.92	47391	4.621	3.00	33412
	16.3	25.7	60	25.5	50037	3.98	3.68	48780	3.875	3.69	38035
			70	25.7	49732	4.417	3.30	48475	4.312	3.29	36167
			80	26.0	49391	4.894	2.96	48134	4.789	2.94	34117
40	8.6	7.2	60	30.6	53969	4.045	3.91	52713	3.716	4.15	41842
			70	31.1	53626	4.488	3.50	52370	4.159	3.69	39916
			80	31.5	53255	4.974	3.14	51998	4.645	3.28	37837
	12.2	14.4	60	33.1	55629	4.073	4.00	54373	3.815	4.17	43448
			70	33.5	55189	4.516	3.58	53933	4.258	3.71	41409
			80	33.8	54715	5.004	3.20	53459	4.746	3.30	39197
	16.3	25.7	60	34.7	56772	4.092	4.06	55516	3.987	4.08	44478
			70	35.0	56185	4.535	3.63	54929	4.430	3.63	42371
			80	35.3	55627	5.023	3.24	54371	4.918	3.24	40078
50	8.6	7.2	60	39.2	60295	4.149	4.26	59039	3.820	4.53	48261
			70	39.7	60096	4.607	3.82	58840	4.278	4.03	46061
			80	40.2	59525	5.105	3.41	58268	4.776	3.57	43745
	12.2	14.4	60	42.0	62329	4.184	4.36	61072	3.926	4.55	50280
			70	42.4	61935	4.641	3.91	60678	4.383	4.05	47861
			80	42.8	61212	5.141	3.49	59955	4.883	3.59	45380
	16.3	25.7	60	43.9	64016	4.216	4.45	62760	4.111	4.47	51474
			70	44.2	63177	4.665	3.97	61921	4.560	3.98	49034
			80	44.5	62372	5.167	3.53	61115	5.062	3.54	46449
60	8.6	7.2	60	47.6	67428	4.274	4.62	66171	3.945	4.91	55101
			70	48.2	66928	4.738	4.14	65671	4.409	4.36	52627
			80	48.7	66227	5.253	3.69	64971	4.924	3.86	50059
	12.2	14.4	60	50.9	70225	4.327	4.75	68968	4.069	4.96	57464
			70	51.3	69247	4.785	4.24	67990	4.527	4.40	54796
			80	51.8	68266	5.3	3.77	67009	5.042	3.89	52048
	16.3	25.7	60	53.0	71872	4.358	4.83	70615	4.253	4.86	58989
			70	53.3	70727	4.816	4.30	69471	4.711	4.32	56212
			80	53.7	69619	5.332	3.82	68362	5.227	3.83	53292
70	8.6	7.2	60	56.0	75440	4.428	4.99	74184	4.099	5.30	62321
			70	56.6	74329	4.895	4.45	73072	4.566	4.69	59587
			80	57.2	73341	5.424	3.96	72084	5.095	4.14	56721
	12.2	14.4	60	59.6	78382	4.487	5.12	77126	4.229	5.34	65175
			70	60.1	77082	4.957	4.55	75825	4.699	4.72	62199
			80	60.6	75901	5.49	4.05	74644	5.232	4.18	59075
	16.3	25.7	60	62.0	79976	4.518	5.18	78719	4.413	5.22	67129
			70	62.4	78839	4.998	4.62	77582	4.893	4.64	63894
			80	62.8	77492	5.532	4.10	76236	5.427	4.11	60598
80	8.6	7.2	60	64.2	83448	4.595	5.32	82191	4.266	5.64	70120
			70	64.9	82231	5.08	4.74	80974	4.751	4.99	66989
			80	65.6	80925	5.626	4.21	79669	5.297	4.40	63745
	12.2	14.4	60	68.3	86760	4.663	5.45	85504	4.405	5.68	73463
			70	68.9	85459	5.162	4.85	84202	4.904	5.03	70025
			80	69.4	83914	5.712	4.30	82658	5.454	4.44	66531
	16.3	25.7	60	71.0	89388	4.726	5.54	88131	4.621	5.58	75597
			70	71.4	87588	5.218	4.92	86332	5.113	4.94	72040
			80	71.9	85906	5.772	4.36	84649	5.667	4.37	68287
85	8.6	7.2	60	68.3	87706	4.686	5.48	86449	4.357	5.81	74148
			70	69.0	86344	5.185	4.88	85087	4.856	5.13	70809
			80	69.8	84876	5.741	4.33	83619	5.412	4.52	67425
	12.2	14.4	60	72.6	91267	4.771	5.60	90011	4.513	5.84	77744
			70	73.2	89826	5.279	4.98	88569	5.021	5.16	74076
			80	73.8	88098	5.839	4.42	86841	5.581	4.56	70379
	16.3	25.7	60	75.5	94156	4.844	5.69	92900	4.739	5.74	80007
			70	75.9	92129	5.344	5.05	90872	5.239	5.08	76211
			80	76.4	90265	5.909	4.47	89008	5.804	4.49	72274
90	8.6	7.2	60	72.3	92174	4.794	5.63	90917	4.465	5.96	78150
			70	73.1	90568	5.3	5.00	89312	4.971	5.26	74707
			80	73.9	88923	5.866	4.44	87666	5.537	4.64	71138
	12.2	14.4	60	76.9	96328	4.9	5.76	95071	4.642	6.00	82020
			70	77.5	94317	5.407	5.11	93060	5.149	5.29	78197
			80	78.2	92465	5.981	4.53	91208	5.723	4.67	74297
	16.3	25.7	60	79.9	98379	4.954	5.81	97123	4.849	5.86	84650
			70	80.4	96815	5.475	5.18	95558	5.370	5.21	80548
			80	80.9	94730	6.058	4.58	93474	5.953	4.60	76401

# Horizontal Performance Data – Operating Limits

## Air Limits - °F (English units)

	Standard Units		Extended Range Units	
	Cooling	Heating	Cooling	Heating
Min Ambient Air	50°F	50°F	40°F	40°F
Normal Ambient Air	80°F	70°F	80°F	70°F
Max Ambient Air	100°F	85°F	100°F	85°F
Min Ent Air ①, ②	50°F	50°F	50°F	40°F
Normal Ent Air db/wb	80/67°F	70°F	80/67°F	70°F
Max Ent Air db/wb ①, ②	100/83°F	80°F	100/83°F	80°F

## Air Limits - °C (SI units)

	Standard Units		Extended Range Units	
	Cooling	Heating	Cooling	Heating
Min Ambient Air	10°C	10°C	5°C	5°C
Normal Ambient Air	27°C	21°C	27°C	21°C
Max Ambient Air	38°C	29°C	38°C	29°C
Min Ent Air ①, ②	10°C	10°C	10°C	5°C
Normal Ent Air db/wb	27/19°C	21°C	27/19°C	21°C
Max Ent Air db/wb ①, ②	38/28°C	27°C	38/28°C	27°C

## Water - °F (English units)

	Standard Units		Extended Range Units	
	Cooling	Heating	Cooling	Heating
Min Ent Water ①, ②	55°F	55°F	30°F	20°F
Normal Ent Water	85°F	70°F	77°F	40°F
Max Ent Water	110°F	90°F	110°F	90°F

## Water - °C (SI units)

	Standard Units		Extended Range Units	
	Cooling	Heating	Cooling	Heating
Min Ent Water ①, ②	13°C	13°C	-1°C	-6°C
Normal Ent Water	29°C	21°C	25°C	4°C
Max Ent Water	43°C	21°C	43°C	32°C

① At ARI flow rate

② Maximum and minimum values may not be combined. If one value is at maximum or minimum, the other two conditions may not exceed the normal condition for standard units. Extended range units may combine any two maximum conditions, but not more than two, with all other conditions being normal conditions.

## Environment

This equipment is designed for indoor installation only. Sheltered locations such as attics, garages, etc., generally will not provide sufficient protection against extremes in temperature and/or humidity, and equipment performance, reliability, and service life may be adversely affected.

## Power supply

A voltage variation of +10% of nameplate utilization voltage is acceptable. Three-phase system imbalance shall not exceed 2%.

## Additional information for initial start-up only

### Standard units:

Units are designed to start in an ambient of 50°F (10°C), with entering air at 50°F (10°C), with entering water at 70°F (21°C), with both air and water at the flow rates used in the ARI Standard 320-86 rating test, for initial start-up in winter.

**Note:** This is not a normal or continuous operating condition. It is assumed that such a start-up is for the purpose of bringing the building space up to occupancy temperature.

### Extended range units:

Extended range heat pump conditioners are designed to start in an ambient of 40°F (5°C), with entering air at 40°F (5°C), with entering water at 40°F (5°C), with both air and water at the flow rates used in the ARI Standard 320-86 rating test, for initial start-up in winter.

**Note:** This is not a normal or continuous operating condition. It is assumed that such a start-up is for the purpose of bringing the building space up to occupancy temperature.

# Horizontal Correction Factors

## Airflow Correction Factors

	Percent of Nominal Airflow						
	85	90	95	100	105	110	115
Total Cooling Capacity	0.972	0.982	0.993	1.00	1.007	1.010	1.013
Sensible Cooling Capacity	0.926	0.948	0.974	1.00	1.027	1.055	1.066
kW - Cooling	0.977	0.984	0.993	1.00	1.011	1.018	1.028
Total Heat of Rejection	0.975	0.983	0.991	1.00	1.008	1.015	1.018
Total Heating Capacity	0.967	0.978	0.990	1.00	1.009	1.017	1.024
kW - Heating	1.009	1.006	1.003	1.00	0.997	0.995	0.993
Total Heat of Absorption	0.967	0.976	0.989	1.00	1.010	1.019	1.025

## Antifreeze Correction Factors

### Ethylene Glycol

	10%	20%	30%	40%	50%
Cooling Capacity	0.9950	0.9920	0.9870	0.9830	0.9790
Heating Capacity	0.9910	0.9820	0.9770	0.9690	0.9610
Pressure Drop	1.0700	1.1300	1.1800	1.2600	1.2800

### Propylene Glycol

	10%	20%	30%	40%	50%
Cooling Capacity	0.9900	0.9800	0.9700	0.9600	0.9500
Heating Capacity	0.9870	0.9750	0.9620	0.9420	0.9300
Pressure Drop	1.0700	1.1500	1.2500	1.3700	1.4200

### Methanol

	10%	20%	30%	40%	50%
Cooling Capacity	0.9980	0.9720	–	–	–
Heating Capacity	0.9950	0.9700	–	–	–
Pressure Drop	1.0230	1.0570	–	–	–

### Ethanol

	10%	20%	30%	40%	50%
Cooling Capacity	0.9910	0.9510	–	–	–
Heating Capacity	0.9950	0.9600	–	–	–
Pressure Drop	1.0350	0.9600	–	–	–

# Horizontal Electrical Data

Size	Power Voltage-Phase-Hz <sup>1</sup>	Compressor		Fan Motor	Total Unit	Minimum Voltage	Min. Circuit Ampacity	Max. Fuse Size <sup>2</sup>
		RLA	LRA	FLA	FLA			
007	115-1-60	7.2	36.2	0.94	8.1	104	9.9	15.0
	208/230-1-60	3.9	17.7	0.46	4.3	197	5.3	15.0
	265-1-60	3.2	15.0	0.38	3.6	240	4.4	15.0
	230-1-50	3.2	15.0	0.46	3.7	197	4.5	15.0
009	115-1-60	9.6	45.6	1.88	11.5	104	13.9	20.0
	208/230-1-60	5.2	22.2	0.83	6.0	197	7.3	15.0
	265-1-60	4.3	18.8	0.65	4.9	240	6.0	15.0
	230-1-50	4.3	18.8	0.81	5.1	197	6.2	15.0
012	115-1-60	12.4	58.4	1.88	14.3	104	17.4	25.0
	208/230-1-60	6.6	27.9	0.83	7.4	197	9.1	15.0
	265-1-60	5.1	22.2	0.65	5.8	240	7.1	15.0
	230-1-50	5.1	22.2	0.81	6.0	197	7.2	15.0
019	208/230-1-60	8.3	48.0	3.00	11.3	197	13.4	20.0
	265-1-60	7.1	44.0	3.00	10.1	240	11.8	15.0
	230-1-50	7.1	44.0	3.00	10.1	197	11.8	15.0
024	208/230-1-60	9.3	48.0	3.00	12.3	197	14.6	20.0
	265-1-60	7.7	44.0	3.00	10.7	240	12.6	20.0
	208/230-3-60	6.4	58.0	3.00	9.4	197	11.0	15.0
	460-3-60	3.5	30.0	1.70	5.2	416	6.1	15.0
	230-1-50	7.7	44.0	3.00	10.7	197	12.6	20.0
030	208/230-1-60	14.7	72.5	3.00	17.7	197	21.4	35.0
	265-1-60	12.5	61.0	3.00	15.5	240	18.6	30.0
	208/230-3-60	10.4	63.0	3.00	13.4	197	16.1	25.0
	460-3-60	4.5	31.0	1.70	6.2	416	7.3	15.0
	380-3-50	4.5	31.0	1.70	6.2	342	7.3	15.0
036	208/230-1-60	15.8	83.0	3.50	19.3	197	23.3	35.0
	265-1-60	15.4	83.0	2.80	18.2	240	22.0	35.0
	208/230-3-60	11.5	77.0	3.50	15.0	197	17.9	25.0
	460-3-60	5.1	35.0	1.60	6.7	416	8.0	15.0
	380-3-50	5.1	35.0	1.60	6.7	342	8.0	15.0
042	208/230-1-60	19.2	104.0	3.40	22.6	197	27.4	45.0
	208/230-3-60	13.5	88.0	3.40	16.9	197	20.2	30.0
	460-3-60	7.1	46.0	1.50	8.6	416	10.3	15.0
	575-3-60	5.0	34.0	1.60	6.6	520	7.9	15.0
	380-3-50	6.4	43.0	1.50	7.9	342	9.5	15.0
048	208/230-1-60	23.1	134.0	5.30	28.4	197	34.1	50.0
	208/230-3-60	16.0	91.0	5.30	21.3	197	25.3	40.0
	460-3-60	7.1	46.0	2.00	9.1	416	10.8	15.0
	575-3-60	5.6	37.0	1.80	7.4	520	8.8	15.0
	380-3-50	7.1	43.0	2.00	9.1	342	10.8	15.0
060	208/230-1-60	27.6	158.0	5.30	32.9	197	39.8	60.0
	208/230-3-60	18.1	137.0	5.30	23.4	197	28.0	45.0
	460-3-60	9.0	62.0	2.00	11.0	416	13.2	20.0
	575-3-60	7.6	50.0	1.80	9.4	520	11.3	15.0
	380-3-50	9.0	62.0	2.00	11.0	342	13.2	20.0

1. 208-230 volt units (60 Hz) are shipped for 208 volt operation; for 230 volt operation, the tap on the 24 volt transformer must be changed from the 208 volt tap to the 230 volt tap.
2. Maximum time delay (Class 5) fuse or HACR type circuit breaker: values are amps. HACR circuit breakers may only be available for 208 and 230 volt single phase operation.

# Horizontal General Data

## Physical Data

Unit Size	007	009	012	019	024
Fan Wheel - D x W (In.)	6.3 x 6.0	6.3 x 6.0	6.2 x 7.4	9.5 x 7.1	9.5 x 7.1
Fan Motor Horsepower	1/20	1/8	1/8	1/3	1/3
Coil Face Area (Sq. Ft.)	0.97	0.97	1.11	2.75	2.75
Coil Rows	3	3	3	3	3
Refrigerant Charge (Oz.)	16	16	18	37	37
Filter, (Qty.) Size (In.)	(1) 10 x 20			(1) 18 x 24	
Water Connections, Female NPT (In.)	1/2	1/2	1/2	1/2	1/2
Condensate Connections, Female NPT (In.)	3/4	3/4	3/4	3/4	3/4
Weight, Operate (Lbs.)	98	100	100	195	195
Weight, Shipping (Lbs.)	120	122	122	214	214

Unit Size	030	036	042	048	060
Fan Wheel - D x W (In.)	9.5 x 7.1	9.5 x 7.1	12.9 x 11.1	12.9 x 11.1	12.9 x 11.1
Fan Motor Horsepower	1/3	1/2	1/2	3/4	3/4
Coil Face Area (Sq. Ft.)	3.43	3.43	4.43	4.43	6.11
Coil Rows	3	3	3	3	3
Refrigerant Charge (Oz.)	44	44	52	52	72
Filter, (Qty.) Size (In.)	(1) 19 x 27	(1) 19 x 27	(2) 16 x 22.5		(2) 22 x 22
Water Connections, Female NPT (In.)	3/4	3/4	3/4	3/4	3/4
Condensate Connections, Female NPT (In.)	3/4	3/4	3/4	3/4	3/4
Weight, Operate (Lbs.)	225	223	293	298	332
Weight, Shipping (Lbs.)	244	242	314	319	351

## Fan Performance

60 cycle, 208 volts, single phase (includes allowance for dry coil and filter)

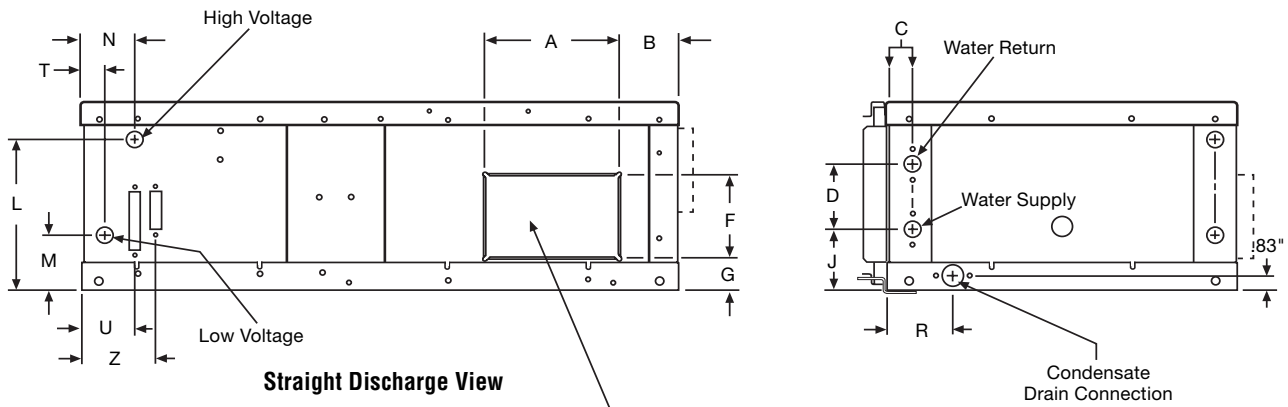
Size	Speed	0.10	0.15	0.20	0.25	0.30	0.35	0.40	0.45	0.50	0.55	0.60	0.65	0.70	0.75
007	*High	300	290	280	270	260	250	240	230	210	190	170	160	—	—
009	*High	440	430	420	410	400	380	370	350	340	320	300	290	—	—
012	Low	360	350	340	330	320	300	290	270	250	230	—	—	—	—
012	*High	460	440	430	410	400	380	360	340	320	300	270	—	—	—
019	*Low	1030	1020	1010	1000	990	970	950	920	900	870	830	780	710	630
019	High	1230	1210	1190	1170	1150	1120	1090	1060	1030	990	950	910	860	790
024	Low	—	—	1030	1020	1000	980	950	930	900	870	840	800	750	—
024	*High	1240	1210	1180	1150	1120	1090	1040	1010	980	940	900	850	790	—
030	Low	—	—	—	1010	1010	1000	980	970	950	930	900	870	830	—
030	*High	1260	1250	1240	1230	1220	1190	1170	1140	1120	1090	1050	1020	960	—
036	Low	—	—	1240	1230	1210	1190	1160	1130	1100	1080	—	—	—	—
036	*High	1510	1490	1460	1440	1410	1380	1350	1320	1280	1240	1200	—	—	—
042	Low	—	—	—	—	—	—	1450	1450	1440	1380	1320	1230	1090	—
042	*High	2230	2190	2140	2100	2050	1990	1920	1830	1730	1620	1510	1380	1220	—
048	Low	2140	2120	2080	2030	1990	1940	1880	1820	1760	1690	1600	1390	1190	—
048	*High	—	—	2240	2210	2160	2100	2030	1960	1880	1800	1710	1620	1380	—
060	Low	2250	2200	2160	2110	2060	2010	1940	1870	1800	1730	1650	1550	1450	—
060	*High	2420	2370	2310	2260	2200	2140	2080	2000	1920	1840	1750	1660	1550	—

\* Above fan selections are as wired from the factory.

For wet coil, calculate face velocity (cfm/ coil face area, sq. ft.). Add the following static to the external static pressure for the corresponding face velocity: 300 fpm = 0.05", 400 fpm = 0.10", 500 fpm = 0.14". Re-enter table at the increased external static pressure to determine final cfm.

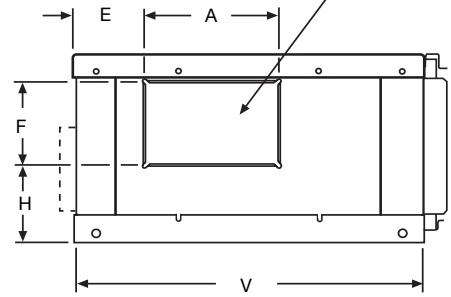
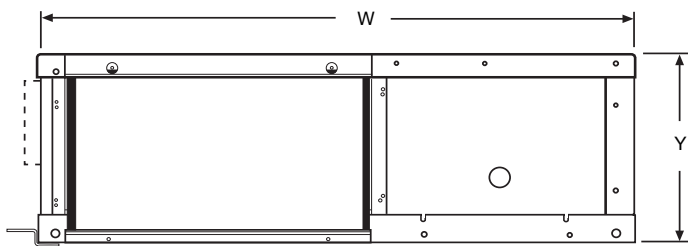
# Dimensional Data – Horizontal Size 007, 009, 012

## Left Hand Return – End and Straight Discharge

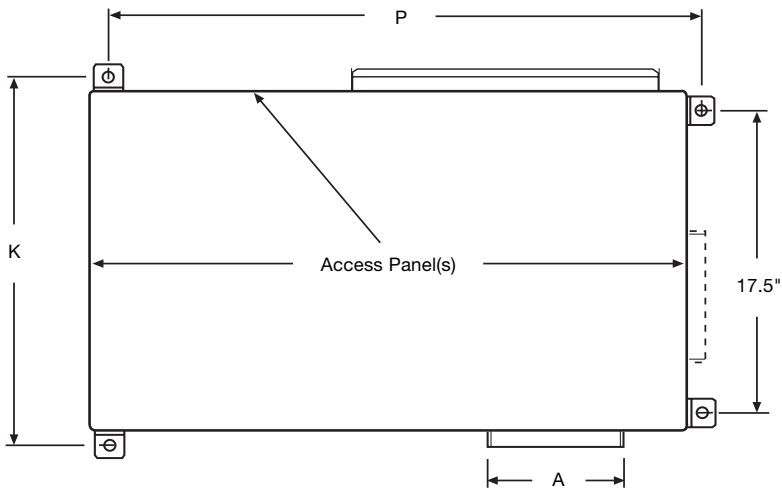


**Straight Discharge View**

Blower Housing Assembly Converts from Straight Discharge to End Discharge



**End Discharge View**

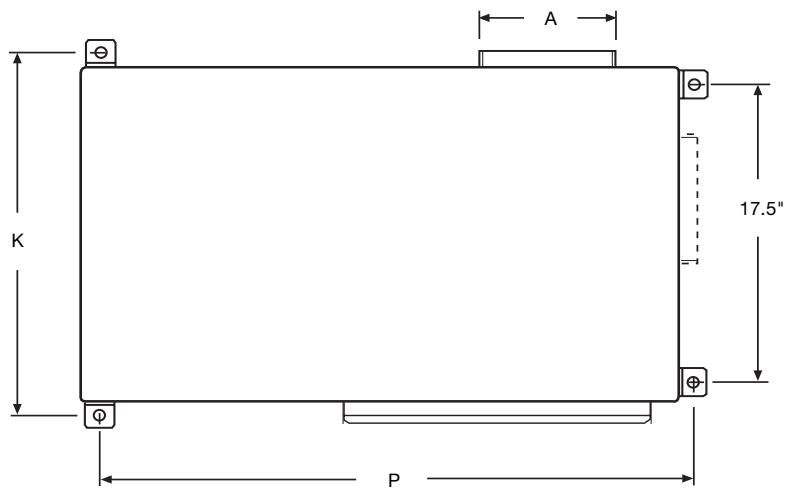
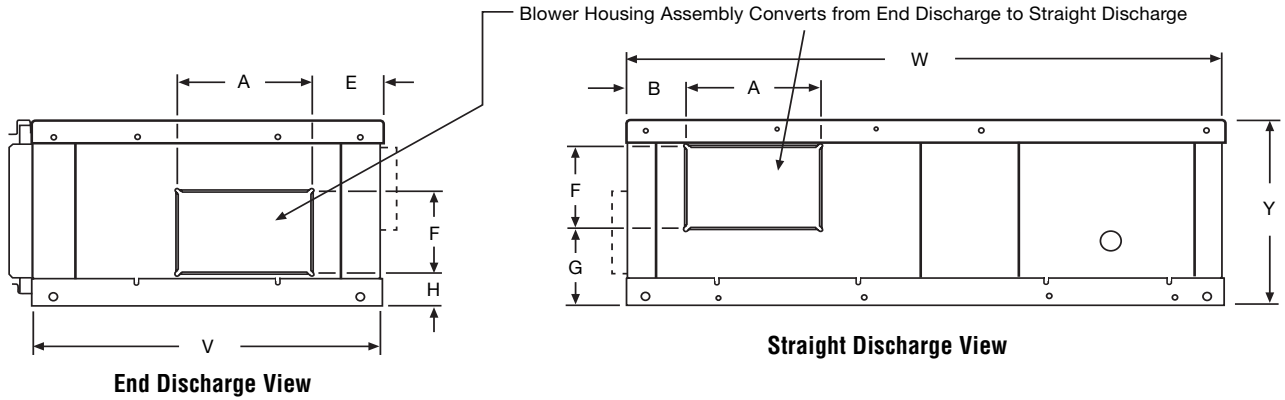
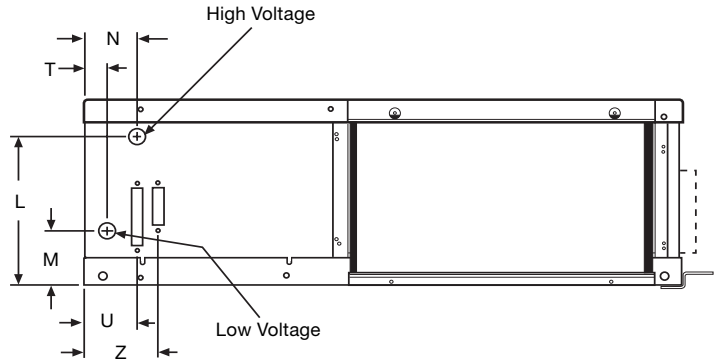
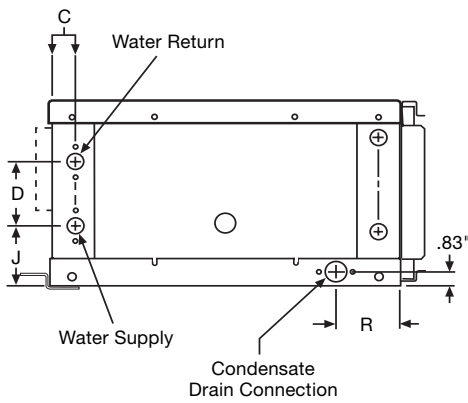


Overall Unit Dimensions = 20"W x 34"L x 11"H

Unit Size	Unit Size 007 - 012 Dimensions (Inches)																				
	A	B	C	D	E	F	G	H	J	K	L	M	N	P	R	T	U	V	W	Y	Z
007-009	7.55	3.25	1.45	3.83	4.12	4.95	1.80	5.00	3.60	22	8.93	3.23	3.00	34	3.73	1.25	3.00	20	34	11	4.32
012	9.60	2.80	1.45	3.83	3.75	4.80	1.80	5.00	3.60	22	8.93	3.23	3.00	34	3.73	1.25	3.00	20	34	11	4.32

# Dimensional Data – Horizontal Size 007, 009, 012

## Right Hand Return – End and Straight Discharge

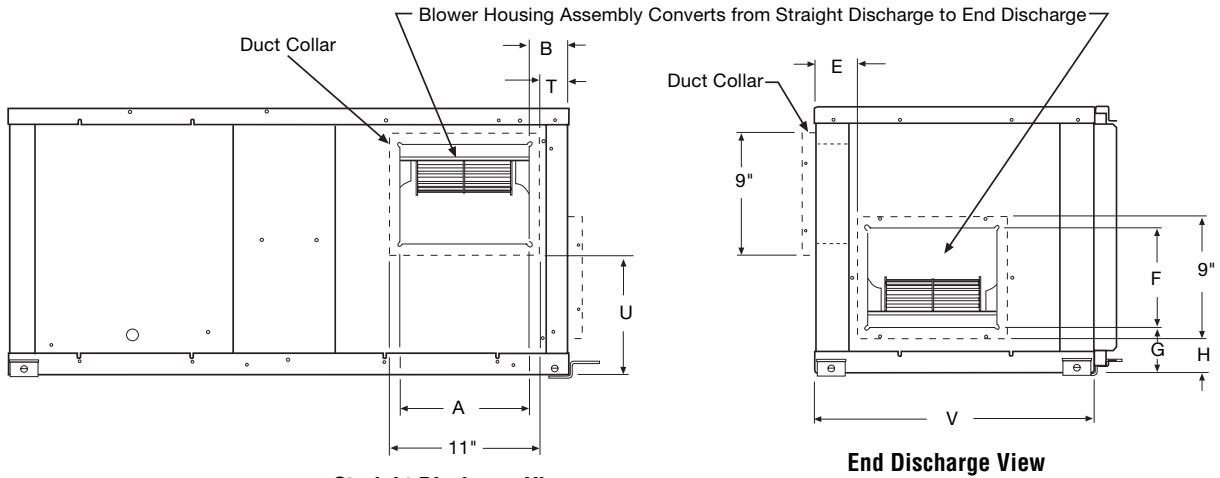
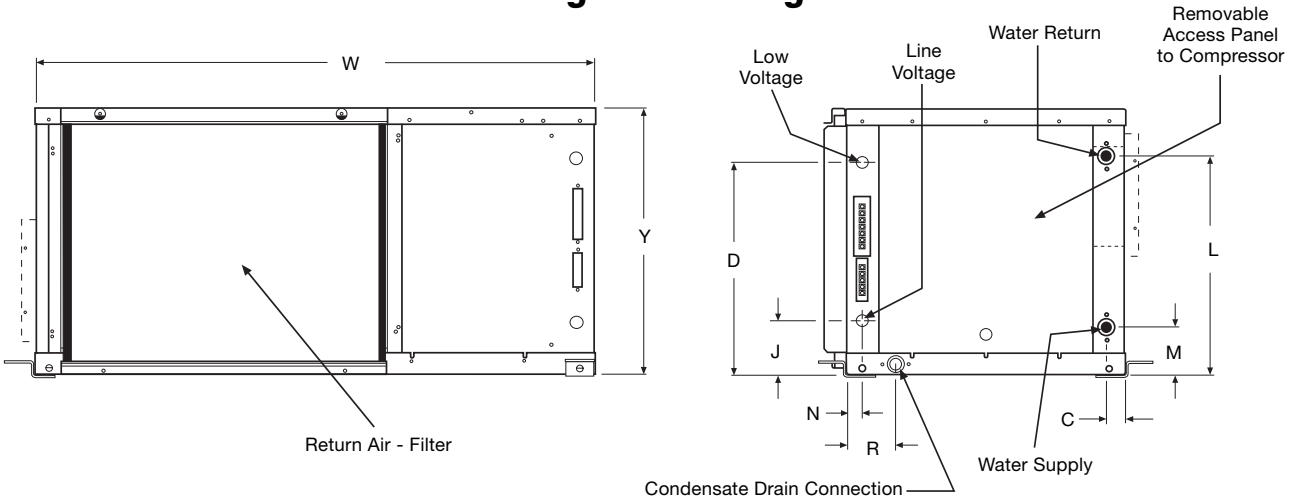


Overall Unit Dimensions = 20"W x 34"L x 11"H

Unit Size	Unit Size 007 - 012 Dimensions (Inches)																				
007-009	A	B	C	D	E	F	G	H	J	K	L	M	N	P	R	T	U	V	W	Y	Z
007-009	7.55	3.25	1.45	3.83	4.12	4.95	5.00	1.80	3.60	22	8.93	3.23	3.00	34	3.73	1.25	3.00	20	34	11	4.32
012	9.60	2.80	1.45	3.83	3.75	4.80	5.00	1.80	3.60	22	8.93	3.23	3.00	34	3.73	1.25	3.00	20	34	11	4.32

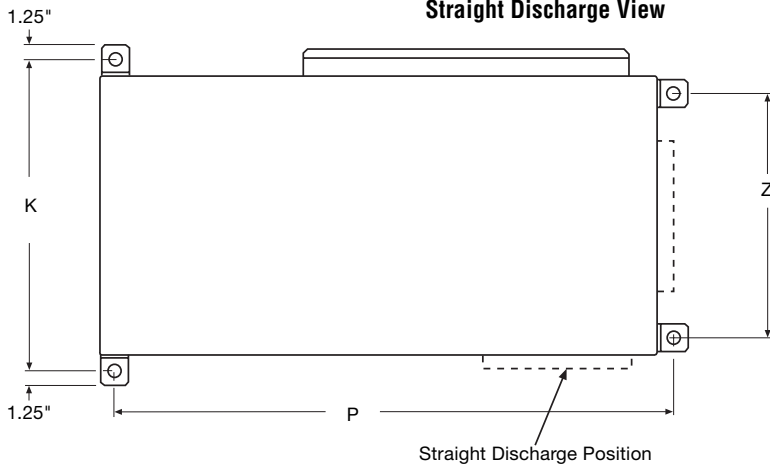
# Dimensional Data – Horizontal Size 019, 024

## Left Hand Return – End and Straight Discharge



**Straight Discharge View**

**End Discharge View**



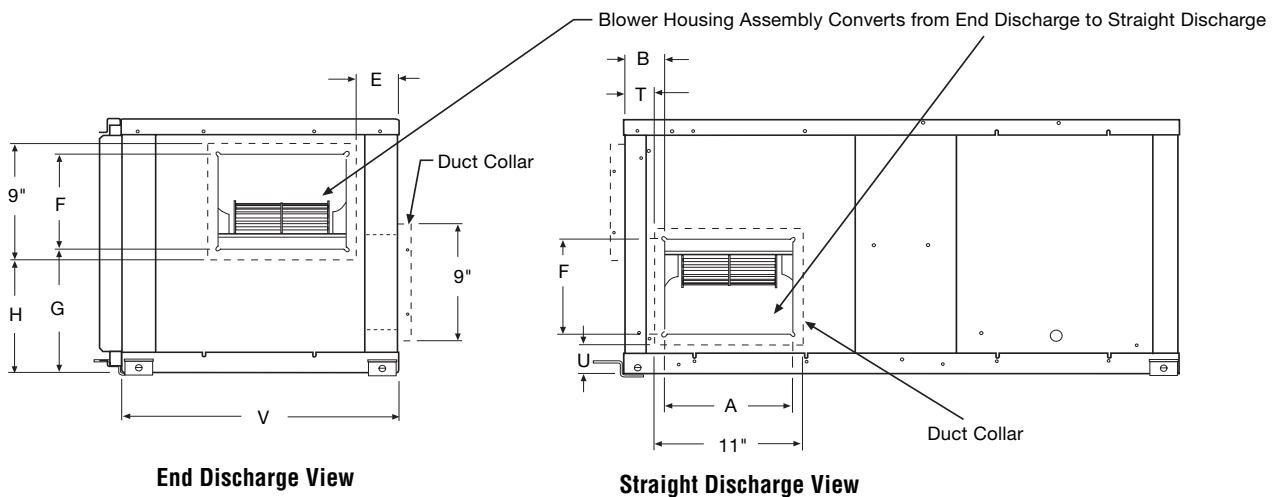
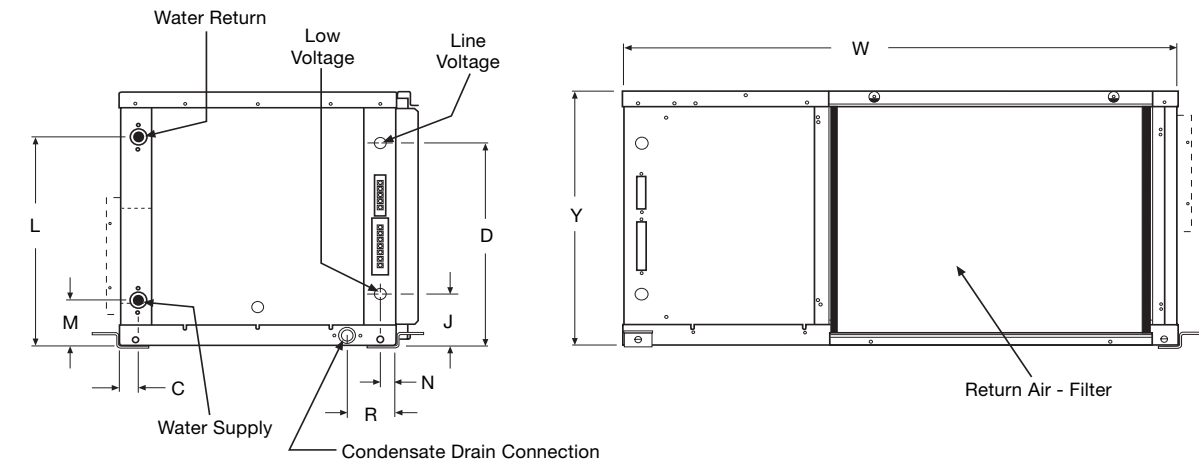
Overall Unit Dimensions = 20"W x 40"L x 19"H

Unit Size	Unit Size 015 - 024 Dimensions (Inches)																				
	A	B	C	D	E	F	G	H	J	K	L	M	N	P	R	T	U	V	W	Y	Z
019	9.26	3.00	1.45	15.30	2.95	7.12	3.15	2.15	3.67	22	15.43	3.60	1.26	40	3.73	2.07	8.30	20	40	19	17.5
024	9.26	3.00	1.45	15.30	2.95	7.12	3.15	2.15	3.67	22	15.43	3.60	1.26	40	3.73	2.07	8.30	20	40	19	17.5



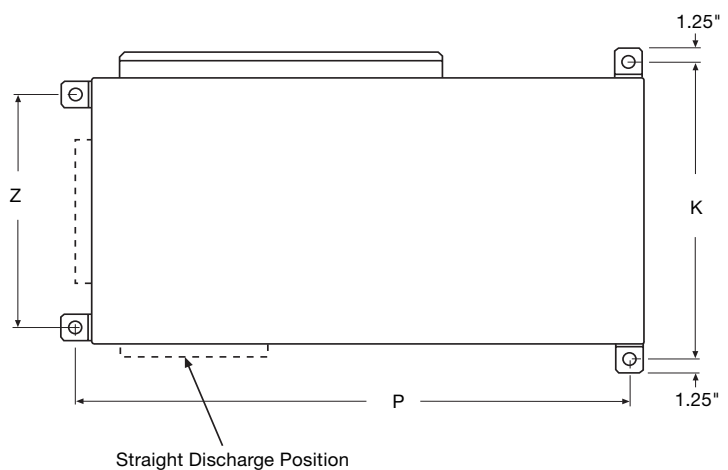
# Dimensional Data – Horizontal Size 019, 024

## Right Hand Return – End and Straight Discharge



End Discharge View

Straight Discharge View



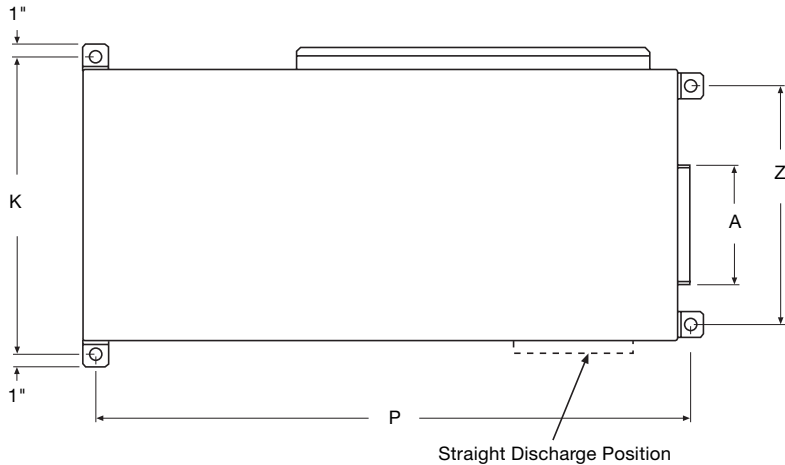
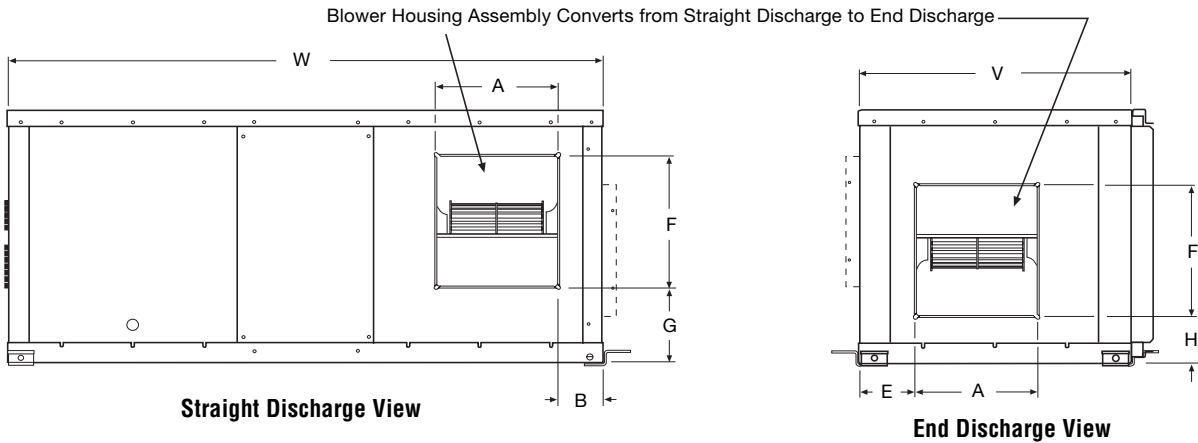
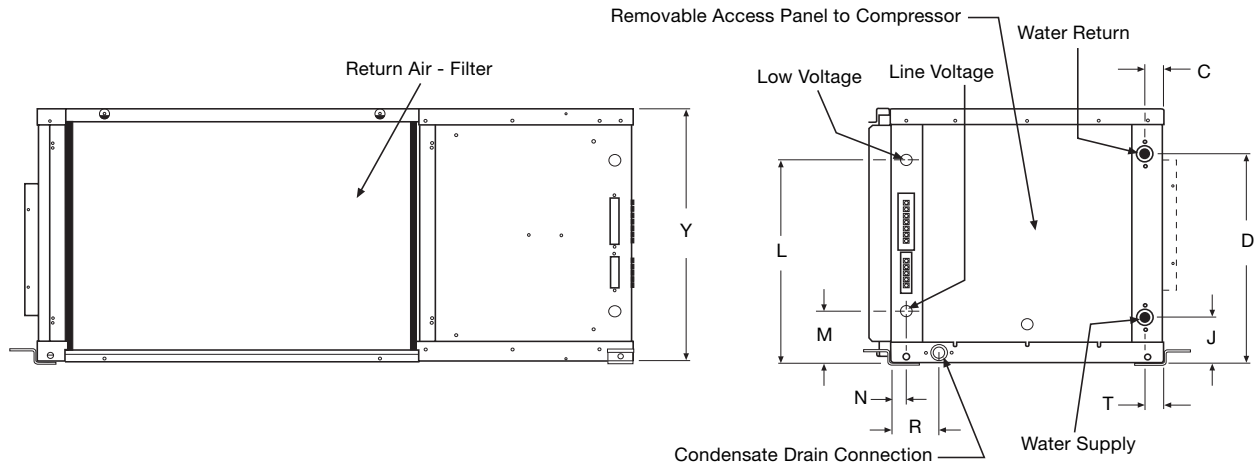
Straight Discharge Position

Overall Unit Dimensions = 20"W x 40"L x 19"H

Unit Size	Unit Size 015 - 024 Dimensions (Inches)																				
	A	B	C	D	E	F	G	H	J	K	L	M	N	P	R	T	U	V	W	Y	Z
019	9.26	4.50	1.45	15.30	2.95	7.12	9.22	8.30	3.67	22	15.43	3.60	1.26	40	3.73	2.07	2.15	20	40	19	17.5
024	9.26	4.50	1.45	15.30	2.95	7.12	9.22	8.30	3.67	22	15.43	3.60	1.26	40	3.73	2.07	2.15	20	40	19	17.5

# Dimensional Data – Horizontal Size 030, 036

## Left Hand Return – End and Straight Discharge

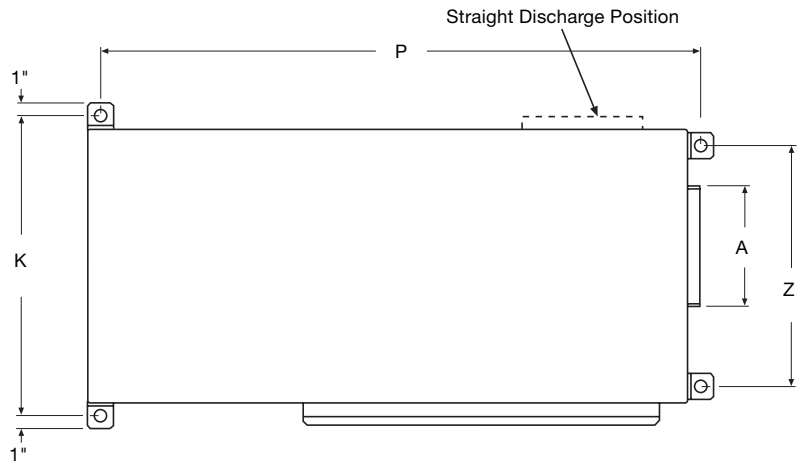
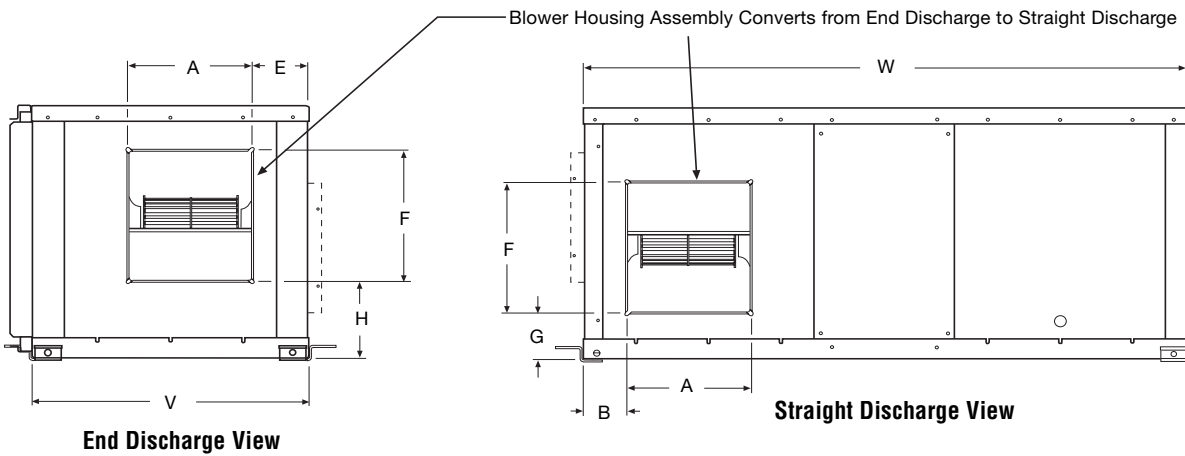
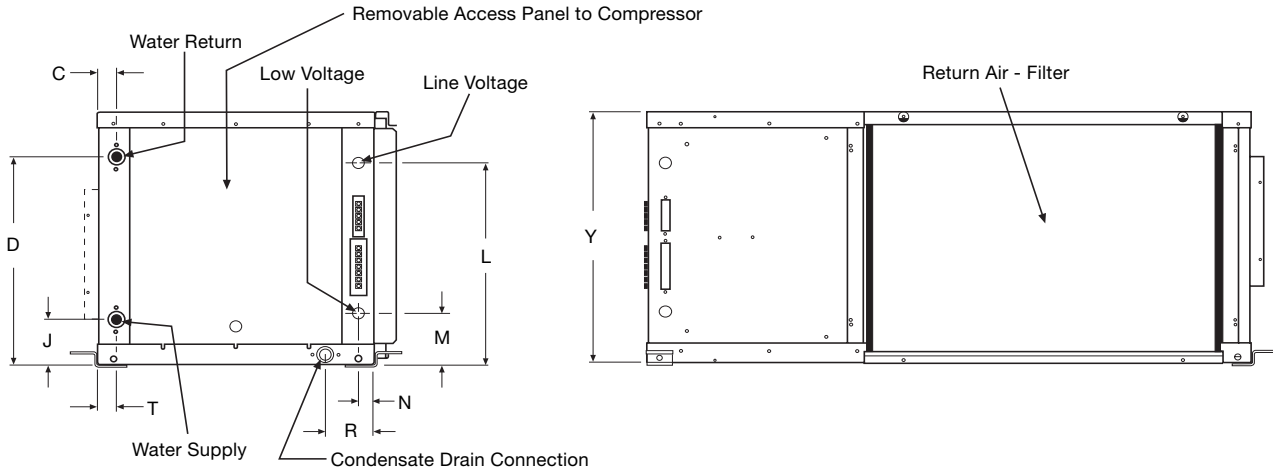


Overall Unit Dimensions = 21"W x 46"L x 20"H

Unit Size	Unit Size 030 - 036 Dimensions (Inches)																			
	A	B	C	D	E	F	G	H	J	K	L	M	N	P	R	T	V	W	Y	Z
030	9.29	3.45	1.45	16.43	4.32	10.23	6.15	4.06	3.60	23	15.93	4.10	1.25	46	3.74	1.45	21	46	20	18.5
036	9.29	3.45	1.45	16.43	4.32	10.23	6.15	4.06	3.60	23	15.93	4.10	1.25	46	3.74	1.45	21	46	20	18.5

# Dimensional Data – Horizontal Size 030, 036

## Right Hand Return – End and Straight Discharge

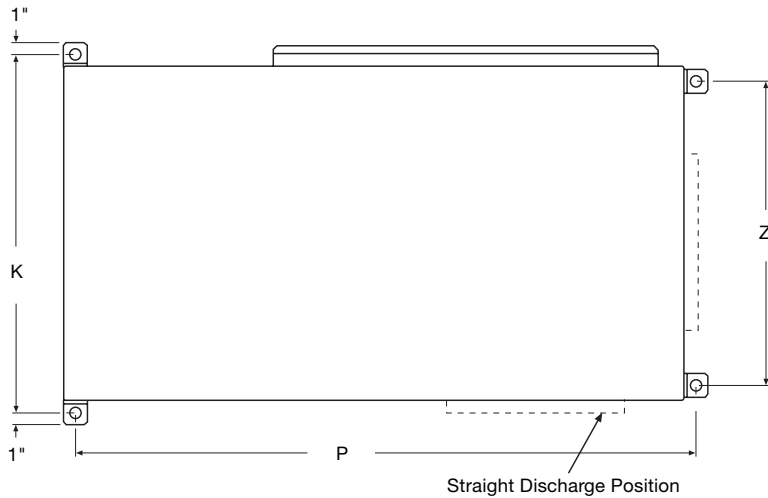
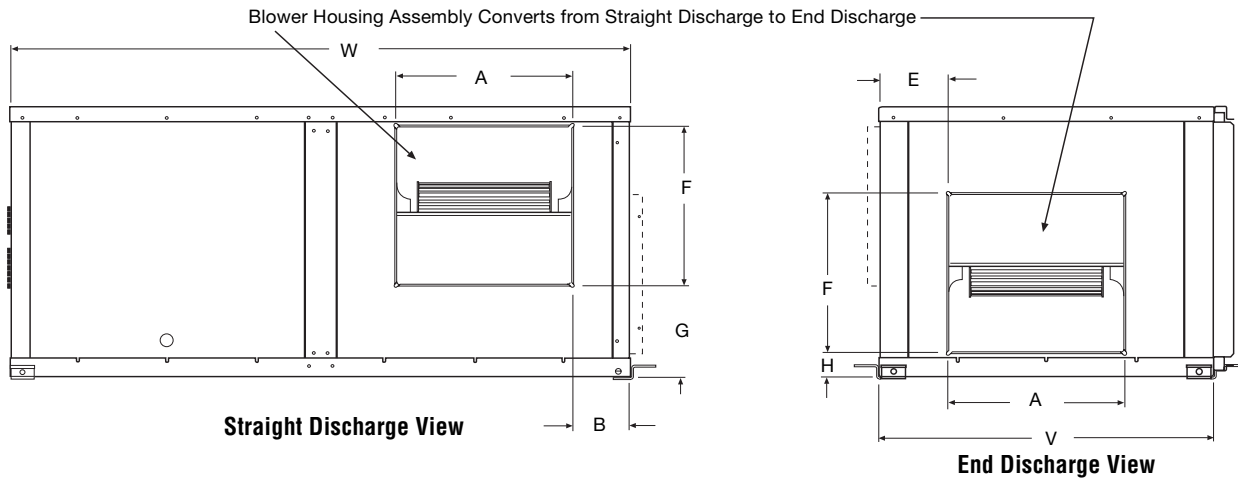
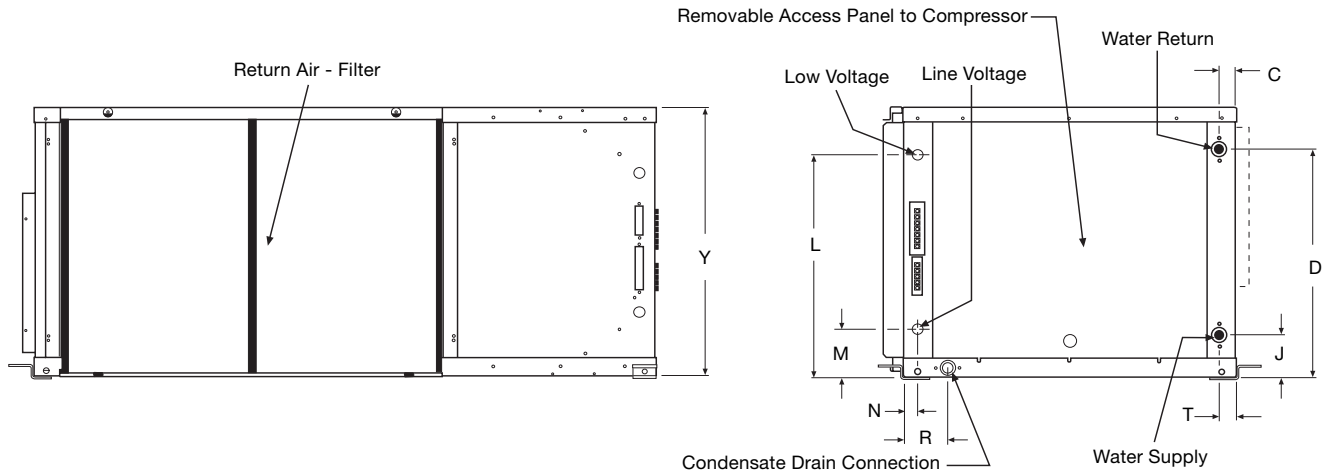


Overall Unit Dimensions = 21"W x 46"L x 20"H

Unit Size	Unit Size 030 - 036 Dimensions (Inches)																			
	A	B	C	D	E	F	G	H	J	K	L	M	N	P	R	T	V	W	Y	Z
030	9.29	3.45	1.45	16.43	4.32	10.23	4.06	6.15	3.60	23	15.93	4.10	1.25	46	3.74	1.45	21	46	20	18.5
036	9.29	3.45	1.45	16.43	4.32	10.23	4.06	6.15	3.60	23	15.93	4.10	1.25	46	3.74	1.45	21	46	20	18.5

# Dimensional Data – Horizontal Size 042, 048, 060

## Left Hand Return – End and Straight Discharge

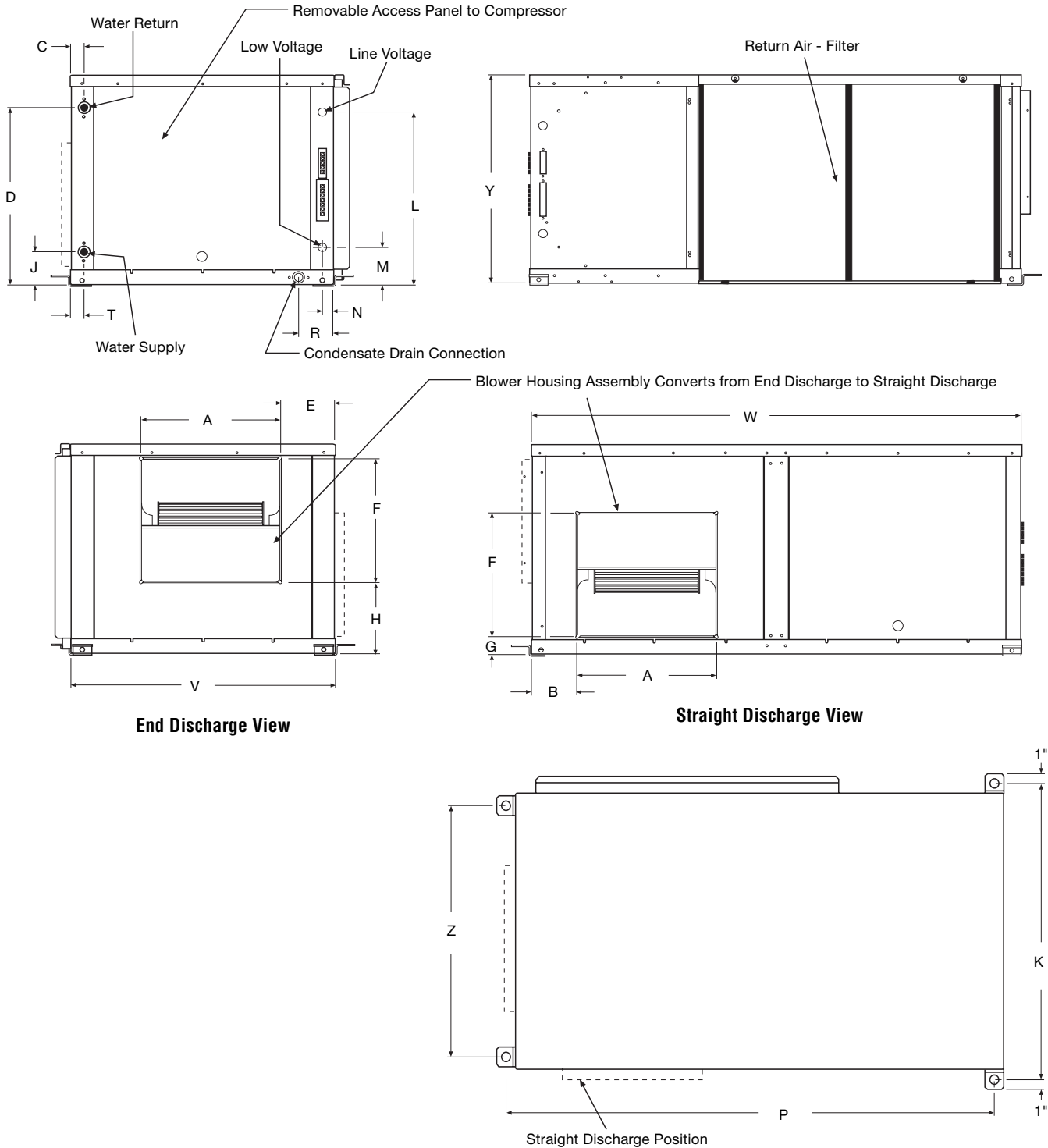


Overall Unit Dimensions = 28"W x 52"L x 23"H

Unit Size	Unit Size 042 - 060 Dimensions (Inches)																			
	A	B	C	D	E	F	G	H	J	K	L	M	N	P	R	T	V	W	Y	Z
042, 048	14.68	4.96	1.45	19.43	5.84	13.43	8.06	1.95	3.60	30	17.43	5.60	1.25	52	3.74	1.45	28	52	23	25.5
060	14.68	4.96	1.45	19.43	5.84	13.43	8.06	1.95	3.60	30	17.43	5.60	1.25	52	3.74	1.45	28	52	23	25.5

# Dimensional Data – Horizontal Size 042, 048, 060

## Right Hand Return – End and Straight Discharge



Overall Unit Dimensions = 28"W x 52"L x 23"H

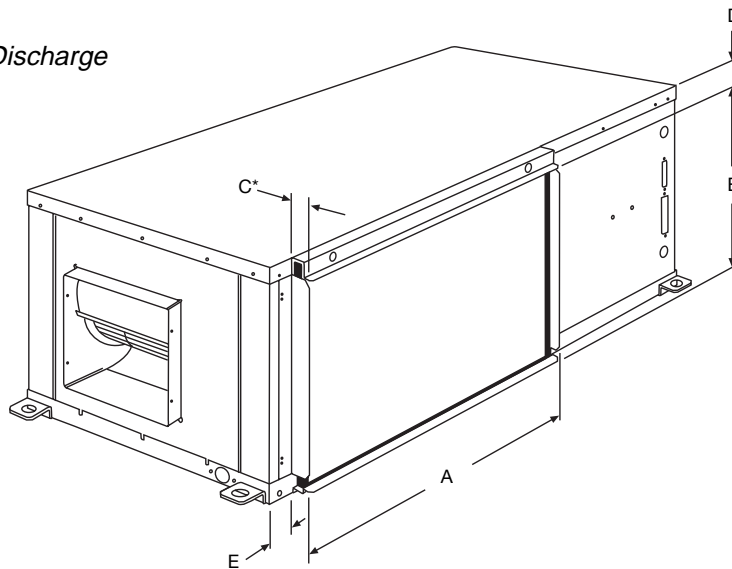
Unit Size	Unit Size 042 - 060 Dimensions (Inches)																			
	A	B	C	D	E	F	G	H	J	K	L	M	N	P	R	T	V	W	Y	Z
042, 048	14.68	4.96	1.45	19.43	5.84	13.43	1.95	8.06	3.60	30	17.43	5.60	1.25	52	3.74	1.45	28	52	23	25.5
060	14.68	4.96	1.45	19.43	5.84	13.43	1.95	8.06	3.60	30	17.43	5.60	1.25	52	3.74	1.45	28	52	23	25.5

# Dimensional Data

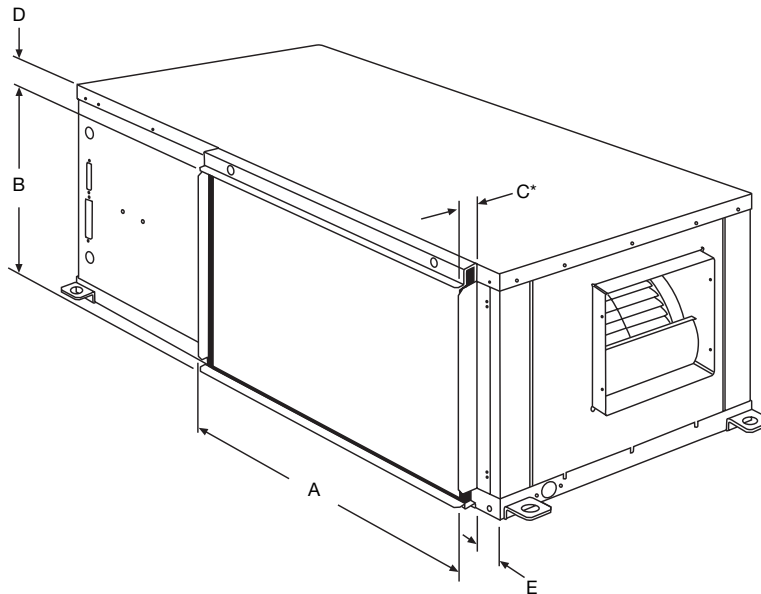
## Filter Rack/Return Air Duct Collar

Unit Sizes 007 thru 060

*Left Hand Return, End Discharge*



*Right Hand Return, End Discharge (Mirror Image)*



### English units

Unit size	Dimensions (inches)					
	A	B	C*		D	E
			STD	OPT		
007, 009, 012	20.15	8.87	1.87	-	1.00	1.24
019, 024	24.07	16.67	1.87	-	1.06	1.46
030, 036	27.32	18	1.66	-	1.06	2.16
042, 048	32.07	21.55	1.66	-	1.06	2.16
060	44.20	20.98	1.66	-	1.06	2.16

### SI units

Unit size	Dimensions (millimeters)					
	A	B	C*		D	E
			STD	OPT		
007, 009, 012	512	225	47	-	27	31
019, 024	611	423	47	-	27	37
030, 036	694	457	42	-	27	55
042, 048	815	418	42	-	27	55
060	1123	533	42	-	27	55

\*Standard filter is 1" (25 mm) and optional filter is 2" (51mm).

# Vertical ISO Performance Data – Water Loop

Water Loop Performance Data per ISO Standard 13256-1.

UNIT SIZE	AIRFLOW		WATERFLOW		VOLTAGE	COOLING				HEATING		
	CFM	L/S	GPM	L/S		BTU/HR	WATTS	EER	COP	BTU/HR	WATTS	COP
007	230	109	1.4	0.09	115-1-60	6200	1815	12.2	3.6	8000	2342	4.3
					208/230-1-60							
					265-1-60							
009	300	142	2.2	0.14	115-1-60	8500	2489	11.8	3.5	11600	3397	4.3
					208/230-1-60							
					265-1-60							
012	400	189	3.1	0.20	115-1-60	11200	3279	12.1	3.6	15200	4451	4.3
					208/230-1-60							
					265-1-60							
019	630	297	5.2	0.33	208/230-1-60	19800	5798	13.9	4.1	24900	7291	4.7
					265-1-60							
024	800	378	5.9	0.37	208/230-1-60	22800	6676	13.0	3.8	30200	8843	4.7
					265-1-60							
					208/230-3-60							
					460-3-60							
030	1000	472	7.2	0.45	208/230-1-60	30400	8901	14.6	4.3	37200	10893	4.8
					265-1-60							
					208/230-3-60							
					460-3-60							
036	1200	566	8.8	0.56	208/230-1-60	35700	10453	15.1	4.4	43800	12825	4.9
					208/230-3-60							
					460-3-60							
042	1400	661	10.7	0.68	208/230-1-60	41000	12005	15.1	4.4	51900	15197	4.9
					208/230-3-60							
					460-3-60							
					575-3-60							
048	1600	755	11.6	0.73	208/230-1-60	45700	13381	13.8	4.0	56900	16661	4.5
					208/230-3-60							
					460-3-60							
					575-3-60							
060	2000	944	14.8	0.93	208/230-1-60	60100	17598	13.9	4.1	74300	21756	4.7
					208/230-3-60							
					460-3-60							
					575-3-60							

**Notes:**

EER = Energy Efficiency Ratio      COP = Coefficient of Performance      L/s = Liters per second

Cooling capacity is based on 80.6°F db, 66.2°F wb (27/19°C) entering air temperature and 86°F (30°C) entering water temperature.  
 Heating capacity is based on 68°F (20°C) entering air temperature and 68°F (20°C) entering water temperature.

# Vertical ISO Performance Data – Ground Loop

Ground Loop Performance Data per ISO Standard 13256-1.

UNIT SIZE	AIRFLOW		WATERFLOW		VOLTAGE	COOLING				HEATING		
	CFM	L/S	GPM	L/S		BTU/HR	WATTS	EER	COP	BTU/HR	WATTS	COP
007	230	109	1.4	0.09	115-1-60	6600	1933	14.2	4.2	5000	1464	3.1
					208/230-1-60							
					265-1-60							
009	300	142	2.2	0.14	115-1-60	9100	2665	13.8	4.0	7400	2167	3.3
					208/230-1-60							
					265-1-60							
012	400	189	3.1	0.20	115-1-60	12000	3514	14.2	4.1	9400	2752	3.2
					208/230-1-60							
					265-1-60							
019	630	297	5.2	0.33	208/230-1-60	21400	6266	16.2	4.7	14800	4334	3.5
					265-1-60							
024	800	378	5.9	0.37	208/230-1-60	24500	7174	15.1	4.4	18400	5388	3.6
					265-1-60							
					208/230-3-60							
					460-3-60							
030	1000	472	7.2	0.45	208/230-1-60	31400	9194	16.9	5.0	24500	7174	3.5
					265-1-60							
					208/230-3-60							
					460-3-60							
036	1200	566	8.8	0.56	208/230-1-60	36900	10805	17.4	5.1	29200	8550	3.7
					208/230-3-60							
					460-3-60							
042	1400	661	10.7	0.68	208/230-1-60	42700	12503	17.6	5.2	33900	9926	3.7
					208/230-3-60							
					460-3-60							
					575-3-60							
048	1600	755	11.6	0.73	208/230-1-60	47900	14026	16.1	4.7	36700	10746	3.3
					208/230-3-60							
					460-3-60							
					575-3-60							
060	2000	944	14.8	0.93	208/230-1-60	61300	17949	16.0	4.7	48200	14113	3.5
					208/230-3-60							
					460-3-60							
					575-3-60							

**Notes:**

EER = Energy Efficiency Ratio      COP = Coefficient of Performance      L/S = Liters per second

Cooling capacity is based on 80.6°F db, 66.2°F wb (27/19°C) entering air temperature and 77°F (25°C) entering water temperature.  
 Heating capacity is based on 68°F (20°C) entering air temperature and 32°F (0°C) entering water temperature.



# Vertical ISO Performance Data – Ground Source

Ground Source Performance Data per ISO Standard 13256-1.

UNIT SIZE	AIRFLOW		WATERFLOW		VOLTAGE	COOLING				HEATING		
	CFM	L/S	GPM	L/S		BTU/HR	WATTS	EER	COP	BTU/HR	WATTS	COP
007	230	109	1.4	0.09	115-1-60	7200	2108	18.5	5.4	6500	1903	3.7
					208/230-1-60							
					265-1-60							
009	300	142	2.2	0.14	115-1-60	10200	2987	18.6	5.4	9500	2782	3.8
					208/230-1-60							
					265-1-60							
012	400	189	3.1	0.20	115-1-60	12300	3602	17.2	5.0	12600	3689	3.9
					208/230-1-60							
					265-1-60							
019	630	297	5.2	0.33	208/230-1-60	23900	6998	20.8	6.1	20000	5856	4.2
					265-1-60							
					208/230-1-60							
024	800	378	5.9	0.37	208/230-1-60	27500	8052	20.1	5.9	24500	7174	4.2
					265-1-60							
					208/230-3-60							
					460-3-60							
030	1000	472	7.2	0.45	208/230-1-60	34300	10043	22.6	6.6	31200	9136	4.3
					265-1-60							
					208/230-3-60							
					460-3-60							
036	1200	566	8.8	0.56	208/230-1-60	40200	11771	23.1	6.8	36800	10775	4.4
					208/230-3-60							
					460-3-60							
042	1400	661	10.7	0.68	208/230-1-60	46300	13557	23.5	6.9	42700	12503	4.4
					208/230-3-60							
					460-3-60							
					575-3-60							
048	1600	755	11.6	0.73	208/230-1-60	51800	15168	20.9	6.1	47600	13938	4.0
					208/230-3-60							
					460-3-60							
					575-3-60							
060	2000	944	14.8	0.93	208/230-1-60	66200	19384	20.8	6.1	61300	17949	4.2
					208/230-3-60							
					460-3-60							
					575-3-60							

**Notes:**

EER = Energy Efficiency Ratio      COP = Coefficient of Performance      L/S = Liters per second

Cooling capacity is based on 80.6°F db, 66.2°F wb (27/19°C) entering air temperature and 59°F (15°C) entering water temperature.  
 Heating capacity is based on 68°F (20°C) entering air temperature and 50°F (10°C) entering water temperature.

# Cooling Capacity Data – Vertical Unit Size 007

EWT	GPM	WPD	System Cooling						ISO System Cooling			
			EA	LWT	TOT	SEN	kW	EER	TOT	kW	EER	THR
30	1.0	1.5	75/63	48.0	6945	5903	0.239	29.0	7093	0.197	36.0	7727
			80/67	49.3	7507	6115	0.237	31.6	7654	0.195	39.3	8295
			85/71	50.7	8099	6309	0.235	34.4	8246	0.193	42.7	8890
	1.4	3.0	75/63	42.8	7016	5941	0.198	35.4	7163	0.158	45.4	7679
			80/67	43.8	7600	6159	0.194	39.1	7747	0.154	50.4	8265
			85/71	44.8	8212	6359	0.189	43.4	8360	0.149	56.2	8868
	1.9	5.5	75/63	39.4	7060	5963	0.170	41.5	7207	0.134	54.0	7641
			80/67	40.1	7658	6188	0.163	46.9	7805	0.127	61.7	8236
			85/71	40.8	8287	6392	0.157	52.7	8434	0.121	70.0	8852
40	1.0	1.5	75/63	58.2	6790	5824	0.315	21.5	6938	0.273	25.4	7788
			80/67	59.5	7321	6027	0.312	23.5	7469	0.270	27.7	8324
			85/71	60.8	7883	6216	0.309	25.5	8031	0.267	30.1	8889
	1.4	3.0	75/63	53.0	6872	5866	0.279	24.6	7019	0.239	29.4	7769
			80/67	53.9	7422	6075	0.273	27.2	7570	0.233	32.5	8316
			85/71	54.9	8007	6270	0.268	29.9	8155	0.228	35.8	8897
	1.9	5.5	75/63	49.5	6917	5890	0.254	27.2	7064	0.218	32.5	7742
			80/67	50.2	7485	6104	0.247	30.3	7633	0.211	36.3	8301
			85/71	50.9	8086	6304	0.240	33.7	8233	0.204	40.4	8896
50	1.0	1.5	75/63	68.3	6610	5732	0.384	17.2	6758	0.342	19.8	7812
			80/67	69.5	7118	5931	0.381	18.7	7265	0.339	21.4	8315
			85/71	70.8	7652	6116	0.378	20.2	7799	0.336	23.2	8854
	1.4	3.0	75/63	63.1	6701	5778	0.351	19.1	6849	0.311	22.0	7803
			80/67	63.9	7226	5982	0.346	20.9	7374	0.306	24.1	8324
			85/71	64.9	7783	6173	0.340	22.9	7931	0.300	26.5	8880
	1.9	5.5	75/63	59.6	6757	5806	0.329	20.5	6905	0.293	23.6	7795
			80/67	60.3	7295	6014	0.322	22.6	7443	0.286	26.1	8325
			85/71	60.9	7866	6208	0.315	25.0	8014	0.279	28.8	8882
60	1.0	1.5	75/63	78.3	6412	5631	0.447	14.3	6560	0.405	16.2	7790
			80/67	79.4	6896	5828	0.445	15.5	7044	0.403	17.5	8275
			85/71	80.6	7404	6010	0.443	16.7	7551	0.401	18.8	8785
	1.4	3.0	75/63	73.1	6512	5682	0.417	15.6	6660	0.377	17.7	7803
			80/67	73.9	7012	5882	0.413	17.0	7159	0.373	19.2	8299
			85/71	74.8	7542	6069	0.408	18.5	7690	0.368	20.9	8822
	1.9	5.5	75/63	69.6	6572	5712	0.397	16.5	6719	0.361	18.6	7808
			80/67	70.3	7085	5916	0.391	18.1	7233	0.355	20.4	8312
			85/71	70.9	7629	6106	0.384	19.9	7777	0.348	22.4	8843
70	1.0	1.5	75/63	88.2	6195	5522	0.507	12.2	6343	0.465	13.6	7744
			80/67	89.3	6657	5716	0.506	13.2	6805	0.464	14.7	8214
			85/71	90.5	7141	5899	0.505	14.1	7289	0.463	15.7	8704
	1.4	3.0	75/63	83.1	6302	5575	0.479	13.2	6450	0.439	14.7	7770
			80/67	83.9	6780	5773	0.476	14.2	6927	0.436	15.9	8245
			85/71	84.7	7283	5958	0.472	15.4	7431	0.432	17.2	8745
	1.9	5.5	75/63	79.6	6365	5607	0.460	13.8	6513	0.424	15.4	7792
			80/67	80.2	6858	5809	0.455	15.1	7006	0.419	16.7	8266
			85/71	80.9	7375	5998	0.450	16.4	7523	0.414	18.2	8778
80	1.0	1.5	75/63	98.1	5963	5406	0.564	10.6	6111	0.522	11.7	7672
			80/67	99.1	6401	5599	0.565	11.3	6549	0.523	12.5	8120
			85/71	100.3	6861	5780	0.566	12.1	7008	0.524	13.4	8598
	1.4	3.0	75/63	93.0	6075	5461	0.538	11.3	6223	0.498	12.5	7708
			80/67	93.8	6530	5657	0.536	12.2	6677	0.496	13.5	8171
			85/71	94.6	7010	5843	0.534	13.1	7157	0.494	14.5	8649
	1.9	5.5	75/63	89.6	6145	5496	0.520	11.8	6292	0.484	13.0	7730
			80/67	90.2	6612	5696	0.517	12.8	6760	0.481	14.1	8196
			85/71	90.8	7105	5883	0.513	13.8	7252	0.477	15.2	8687
85	1.0	1.5	75/63	103.0	5841	5344	0.593	9.8	5988	0.551	10.9	7628
			80/67	104.0	6266	5537	0.595	10.5	6414	0.553	11.6	8073
			85/71	105.1	6716	5719	0.596	11.3	6863	0.554	12.4	8530
	1.4	3.0	75/63	97.9	5955	5401	0.566	10.5	6103	0.526	11.6	7669
			80/67	98.7	6397	5597	0.566	11.3	6545	0.526	12.5	8126
			85/71	99.5	6868	5783	0.564	12.2	7015	0.524	13.4	8591
	1.9	5.5	75/63	94.5	6027	5437	0.549	11.0	6174	0.513	12.0	7693
			80/67	95.1	6486	5637	0.547	11.9	6633	0.511	13.0	8155
			85/71	95.7	6965	5824	0.544	12.8	7112	0.508	14.0	8628
90	1.0	1.5	75/63	107.9	5713	5281	0.621	9.2	5861	0.579	10.1	7580
			80/67	108.9	6129	5474	0.625	9.8	6276	0.583	10.8	8019
			85/71	110.0	6567	5657	0.627	10.5	6714	0.585	11.5	8471
	1.4	3.0	75/63	102.9	5830	5339	0.595	9.8	5978	0.555	10.8	7624
			80/67	103.6	6264	5536	0.596	10.5	6412	0.556	11.5	8075
			85/71	104.4	6721	5722	0.595	11.3	6868	0.555	12.4	8536
	1.9	5.5	75/63	99.5	5903	5375	0.578	10.2	6051	0.542	11.2	7652
			80/67	100.1	6348	5574	0.577	11.0	6496	0.541	12.0	8108
			85/71	100.7	6819	5762	0.575	11.9	6966	0.539	12.9	8578
100	1.0	1.5	75/63	117.7	5440	5146	0.680	8.0	5587	0.638	8.8	7475
			80/67	118.7	5839	5343	0.686	8.5	5986	0.644	9.3	7904
			85/71	119.7	6257	5529	0.691	9.1	6405	0.649	9.9	8341
	1.4	3.0	75/63	112.7	5563	5207	0.653	8.5	5711	0.613	9.3	7524
			80/67	113.4	5978	5406	0.656	9.1	6125	0.616	10.0	7961
			85/71	114.2	6416	5595	0.658	9.7	6564	0.618	10.6	8409
	1.9	5.5	75/63	109.4	5641	5245	0.636	8.9	5788	0.600	9.7	7555
			80/67	110.0	6071	5448	0.638	9.5	6219	0.602	10.3	7999
			85/71	110.5	6517	5637	0.638	10.2	6664	0.602	11.1	8452
110	1.0	1.5	75/63	127.4	5154	5006	0.741	7.0	5301	0.699	7.6	7360
			80/67	128.4	5534	5206	0.750	7.4	5682	0.708	8.0	7779
			85/71	129.5	5934	5397	0.758	7.8	6081	0.716	8.5	8214
	1.4	3.0	75/63	122.5	5281	5068	0.714	7.4	5429	0.674	8.1	7413
			80/67	123.3	5678	5270	0.719	7.9	5826	0.679	8.6	7839
			85/71	124.0	6096	5463	0.724	8.4	6243	0.684	9.1	8274
	1.9	5.5	75/63	119.3	5362	5108	0.696	7.7	5510	0.660	8.4	7446
			80/67	119.8	5768	5312	0.700	8.2	5916	0.664	8.9	7872
			85/71	120.4	6199	5506	0.703	8.8	6347	0.667	9.5	8318

# Heating Capacity Data – Vertical Unit Size 007

EWT	GPM	WPD	System Heating					ISO System Heating			
			EA	LWT	TOT	kW	COP	TOT	kW	COP	THA
20	1.0	1.5	60	12.8	4321	0.460	2.75	4173	0.418	2.92	3127
			70	13.1	4320	0.493	2.56	4172	0.451	2.71	3022
			80	13.4	4269	0.523	2.39	4121	0.481	2.51	2886
	1.4	3.0	60	14.7	4453	0.464	2.81	4306	0.424	2.98	3249
			70	14.9	4443	0.498	2.61	4296	0.458	2.75	3134
			80	15.1	4389	0.529	2.43	4241	0.489	2.54	2989
	1.9	5.5	60	16.0	4549	0.467	2.85	4402	0.431	2.99	3336
			70	16.1	4529	0.502	2.64	4381	0.466	2.76	3216
			80	16.3	4468	0.533	2.45	4320	0.497	2.55	3059
30	1.0	1.5	60	21.4	4975	0.479	3.04	4827	0.437	3.23	3735
			70	21.7	4951	0.517	2.80	4803	0.475	2.96	3600
			80	22.1	4897	0.553	2.59	4750	0.511	2.72	3437
	1.4	3.0	60	23.6	5139	0.484	3.11	4992	0.444	3.29	3890
			70	23.8	5105	0.522	2.86	4957	0.482	3.01	3743
			80	24.1	5041	0.559	2.64	4894	0.519	2.76	3567
	1.9	5.5	60	25.1	5254	0.487	3.16	5106	0.451	3.32	4001
			70	25.3	5216	0.526	2.90	5068	0.490	3.03	3847
			80	25.6	5142	0.563	2.67	4995	0.527	2.78	3660
40	1.0	1.5	60	29.8	5668	0.497	3.34	5521	0.455	3.55	4398
			70	30.2	5628	0.539	3.06	5481	0.497	3.23	4229
			80	30.6	5561	0.579	2.81	5413	0.537	2.95	4039
	1.4	3.0	60	32.4	5875	0.502	3.43	5728	0.462	3.63	4589
			70	32.7	5816	0.545	3.12	5669	0.505	3.29	4407
			80	33.0	5738	0.586	2.87	5590	0.546	3.00	4202
	1.9	5.5	60	34.2	6021	0.505	3.49	5874	0.469	3.67	4728
			70	34.5	5953	0.549	3.17	5805	0.513	3.32	4534
			80	34.7	5864	0.591	2.90	5717	0.555	3.02	4317
50	1.0	1.5	60	38.1	6413	0.514	3.65	6266	0.472	3.89	5105
			70	38.6	6351	0.560	3.32	6204	0.518	3.51	4907
			80	39.1	6268	0.605	3.03	6121	0.563	3.18	4691
	1.4	3.0	60	41.1	6662	0.519	3.76	6515	0.479	3.99	5343
			70	41.5	6580	0.566	3.40	6432	0.526	3.58	5125
			80	41.9	6483	0.612	3.10	6335	0.572	3.25	4887
	1.9	5.5	60	43.3	6840	0.522	3.84	6692	0.486	4.04	5513
			70	43.5	6748	0.570	3.47	6601	0.534	3.62	5281
			80	43.8	6636	0.618	3.14	6488	0.582	3.27	5029
60	1.0	1.5	60	46.4	7197	0.530	3.97	7050	0.488	4.23	5861
			70	46.9	7113	0.580	3.59	6965	0.538	3.79	5626
			80	47.5	7013	0.630	3.26	6865	0.588	3.42	5379
	1.4	3.0	60	49.8	7494	0.536	4.09	7347	0.496	4.34	6147
			70	50.2	7390	0.587	3.69	7243	0.547	3.88	5893
			80	50.6	7275	0.638	3.34	7127	0.598	3.49	5624
	1.9	5.5	60	52.2	7710	0.540	4.18	7562	0.504	4.40	6351
			70	52.5	7591	0.592	3.75	7444	0.556	3.92	6080
			80	52.9	7457	0.644	3.39	7309	0.608	3.52	5792
70	1.0	1.5	60	54.5	8021	0.546	4.30	7874	0.504	4.58	6654
			70	55.1	7924	0.600	3.87	7777	0.558	4.08	6385
			80	55.7	7798	0.655	3.48	7650	0.613	3.65	6110
	1.4	3.0	60	58.3	8371	0.552	4.44	8224	0.512	4.71	6992
			70	58.8	8247	0.608	3.97	8099	0.568	4.18	6702
			80	59.3	8111	0.665	3.57	7963	0.625	3.73	6397
	1.9	5.5	60	61.1	8623	0.557	4.53	8476	0.521	4.77	7240
			70	61.5	8478	0.613	4.05	8330	0.577	4.23	6930
			80	61.9	8327	0.671	3.63	8180	0.635	3.77	6601
80	1.0	1.5	60	62.5	8879	0.562	4.62	8731	0.520	4.92	7479
			70	63.2	8750	0.620	4.13	8602	0.578	4.36	7183
			80	63.9	8623	0.681	3.71	8476	0.639	3.88	6872
	1.4	3.0	60	66.8	9294	0.570	4.77	9147	0.530	5.06	7885
			70	67.4	9143	0.629	4.25	8995	0.589	4.47	7551
			80	68.0	8984	0.692	3.80	8836	0.652	3.97	7210
	1.9	5.5	60	69.9	9584	0.576	4.87	9437	0.540	5.12	8167
			70	70.4	9416	0.636	4.33	9268	0.600	4.53	7815
			80	70.8	9241	0.700	3.86	9094	0.664	4.01	7453
85	1.0	1.5	60	66.5	9326	0.571	4.78	9178	0.529	5.08	7904
			70	67.2	9186	0.631	4.26	9038	0.589	4.49	7592
			80	68.0	9044	0.694	3.81	8896	0.652	4.00	7266
	1.4	3.0	60	71.1	9771	0.580	4.93	9623	0.540	5.22	8335
			70	71.6	9605	0.641	4.39	9457	0.601	4.61	7994
			80	72.2	9438	0.706	3.91	9291	0.666	4.09	7630
	1.9	5.5	60	74.3	10083	0.586	5.04	9936	0.550	5.29	8645
			70	74.8	9901	0.648	4.47	9753	0.612	4.67	8273
			80	75.3	9715	0.715	3.98	9567	0.679	4.13	7890
90	1.0	1.5	60	70.5	9778	0.580	4.93	9630	0.538	5.24	8336
			70	71.3	9624	0.641	4.39	9476	0.599	4.63	8008
			80	72.1	9479	0.707	3.92	9331	0.665	4.11	7667
	1.4	3.0	60	75.3	10252	0.589	5.09	10104	0.549	5.39	8809
			70	75.9	10085	0.653	4.52	9938	0.613	4.75	8434
			80	76.5	9900	0.721	4.02	9752	0.681	4.20	8062
	1.9	5.5	60	78.7	10594	0.596	5.20	10446	0.560	5.47	9132
			70	79.2	10391	0.661	4.60	10243	0.625	4.80	8739
			80	79.7	10197	0.730	4.09	10049	0.694	4.24	8335

# Cooling Capacity Data – Vertical Unit Size 009

EWT	GPM	WPD	System Cooling						ISO System Cooling			
			EA	LWT	TOT	SEN	kW	EER	TOT	kW	EER	THR
30	1.3	2.6	75/63	49.7	9649	8431	0.496	19.5	9882	0.430	23.0	11235
			80/67	51.0	10336	8719	0.513	20.1	10568	0.447	23.6	11989
			85/71	52.3	11050	8985	0.530	20.8	11283	0.464	24.3	12766
	1.8	4.9	75/63	44.3	9781	8496	0.472	20.7	10014	0.409	24.5	11301
			80/67	45.2	10487	8788	0.487	21.5	10719	0.424	25.3	12066
			85/71	46.2	11221	9057	0.503	22.3	11453	0.440	26.0	12853
	2.4	8.8	75/63	40.7	9866	8539	0.456	21.6	10099	0.401	25.2	11341
			80/67	41.5	10583	8832	0.470	22.5	10815	0.415	26.1	12109
			85/71	42.2	11331	9102	0.485	23.4	11563	0.430	26.9	12917
40	1.3	2.6	75/63	59.5	9385	8300	0.544	17.3	9618	0.478	20.1	11111
			80/67	60.8	10054	8592	0.560	18.0	10286	0.494	20.8	11841
			85/71	62.1	10754	8864	0.576	18.7	10987	0.510	21.5	12601
	1.8	4.9	75/63	54.1	9522	8368	0.519	18.3	9754	0.456	21.4	11175
			80/67	55.1	10209	8661	0.534	19.1	10441	0.471	22.1	11917
			85/71	56.1	10930	8935	0.549	19.9	11162	0.486	22.9	12701
	2.4	8.8	75/63	50.6	9609	8411	0.504	19.1	9841	0.449	21.9	11212
			80/67	51.4	10311	8707	0.517	19.9	10544	0.462	22.8	11974
			85/71	52.1	11042	8983	0.531	20.8	11274	0.476	23.7	12764
50	1.3	2.6	75/63	69.3	9107	8164	0.593	15.4	9340	0.527	17.7	10983
			80/67	70.5	9758	8457	0.609	16.0	9990	0.543	18.4	11678
			85/71	71.9	10440	8734	0.625	16.7	10672	0.559	19.1	12429
	1.8	4.9	75/63	64.0	9252	8236	0.569	16.3	9485	0.506	18.7	11034
			80/67	64.9	9915	8528	0.583	17.0	10147	0.520	19.5	11773
			85/71	65.9	10618	8807	0.597	17.8	10851	0.534	20.3	12530
	2.4	8.8	75/63	60.5	9333	8275	0.553	16.9	9566	0.498	19.2	11085
			80/67	61.3	10015	8574	0.566	17.7	10248	0.511	20.0	11822
			85/71	62.0	10732	8854	0.580	18.5	10964	0.525	20.9	12595
60	1.3	2.6	75/63	79.1	8811	8019	0.645	13.7	9044	0.579	15.6	10839
			80/67	80.3	9446	8317	0.661	14.3	9679	0.595	16.3	11521
			85/71	81.6	10111	8599	0.677	14.9	10344	0.611	16.9	12248
	1.8	4.9	75/63	73.9	8954	8089	0.620	14.4	9187	0.557	16.5	10891
			80/67	74.8	9605	8389	0.634	15.1	9837	0.571	17.2	11602
			85/71	75.7	10290	8673	0.649	15.9	10522	0.586	17.9	12351
	2.4	8.8	75/63	70.4	9044	8133	0.604	15.0	9277	0.549	16.9	10943
			80/67	71.1	9707	8435	0.617	15.7	9939	0.562	17.7	11656
			85/71	71.8	10405	8720	0.631	16.5	10638	0.576	18.5	12417
70	1.3	2.6	75/63	88.9	8505	7869	0.700	12.2	8738	0.634	13.8	10681
			80/67	90.1	9122	8172	0.716	12.7	9354	0.650	14.4	11359
			85/71	91.3	9767	8458	0.733	13.3	9999	0.667	15.0	12065
	1.8	4.9	75/63	83.7	8647	7939	0.674	12.8	8880	0.611	14.5	10749
			80/67	84.6	9281	8244	0.689	13.5	9514	0.626	15.2	11430
			85/71	85.5	9948	8532	0.704	14.1	10180	0.641	15.9	12167
	2.4	8.8	75/63	80.3	8739	7984	0.658	13.3	8972	0.603	14.9	10793
			80/67	81.0	9384	8290	0.671	14.0	9617	0.616	15.6	11484
			85/71	81.7	10064	8580	0.685	14.7	10297	0.630	16.3	12234
80	1.3	2.6	75/63	98.6	8187	7714	0.758	10.8	8419	0.692	12.2	10526
			80/67	99.8	8785	8021	0.775	11.3	9017	0.709	12.7	11192
			85/71	101.0	9402	8309	0.793	11.9	9635	0.727	13.3	11882
	1.8	4.9	75/63	93.5	8335	7786	0.732	11.4	8567	0.669	12.8	10594
			80/67	94.4	8944	8093	0.747	12.0	9177	0.684	13.4	11275
			85/71	95.3	9590	8386	0.762	12.6	9823	0.699	14.0	11968
	2.4	8.8	75/63	90.2	8425	7830	0.715	11.8	8657	0.660	13.1	10639
			80/67	90.8	9048	8140	0.729	12.4	9281	0.674	13.8	11312
			85/71	91.5	9708	8435	0.743	13.1	9940	0.688	14.4	12031
85	1.3	2.6	75/63	103.5	8024	7635	0.788	10.2	8257	0.722	11.4	10448
			80/67	104.7	8612	7944	0.806	10.7	8845	0.740	12.0	11102
			85/71	105.9	9218	8235	0.825	11.2	9450	0.759	12.5	11779
	1.8	4.9	75/63	98.4	8167	7705	0.761	10.7	8400	0.698	12.0	10513
			80/67	99.3	8773	8016	0.777	11.3	9005	0.714	12.6	11192
			85/71	100.2	9408	8311	0.793	11.9	9640	0.730	13.2	11872
	2.4	8.8	75/63	95.1	8258	7750	0.744	11.1	8491	0.689	12.3	10560
			80/67	95.8	8877	8062	0.759	11.7	9109	0.704	12.9	11233
			85/71	96.4	9525	8360	0.773	12.3	9758	0.718	13.6	11934
90	1.3	2.6	75/63	108.4	7858	7554	0.819	9.6	8091	0.753	10.7	10371
			80/67	109.5	8436	7865	0.838	10.1	8668	0.772	11.2	11027
			85/71	110.7	9030	8157	0.857	10.5	9262	0.791	11.7	11685
	1.8	4.9	75/63	103.3	8002	7624	0.792	10.1	8234	0.729	11.3	10438
			80/67	104.2	8597	7938	0.809	10.6	8830	0.746	11.8	11095
			85/71	105.1	9214	8233	0.825	11.2	9446	0.762	12.4	11777
	2.4	8.8	75/63	100.1	8094	7668	0.775	10.4	8326	0.720	11.6	10486
			80/67	100.7	8701	7984	0.790	11.0	8934	0.735	12.2	11146
			85/71	101.4	9332	8281	0.805	11.6	9565	0.750	12.8	11837
100	1.3	2.6	75/63	118.2	7522	7389	0.885	8.5	7755	0.819	9.5	10236
			80/67	119.3	8077	7705	0.906	8.9	8310	0.840	9.9	10851
			85/71	120.4	8645	8001	0.927	9.3	8878	0.861	10.3	11498
	1.8	4.9	75/63	113.2	7665	7460	0.857	8.9	7898	0.794	9.9	10283
			80/67	114.0	8240	7778	0.875	9.4	8472	0.812	10.4	10925
			85/71	114.9	8831	8076	0.893	9.9	9063	0.830	10.9	11587
	2.4	8.8	75/63	109.9	7757	7504	0.839	9.2	7989	0.784	10.2	10324
			80/67	110.5	8344	7824	0.855	9.8	8576	0.800	10.7	10974
			85/71	111.2	8949	8125	0.872	10.3	9182	0.817	11.2	11641
110	1.3	2.6	75/63	127.9	7175	7218	0.956	7.5	7408	0.890	8.3	10085
			80/67	129.0	7699	7534	0.979	7.9	7931	0.913	8.7	10688
			85/71	130.1	8249	7838	1.002	8.2	8481	0.936	9.1	11316
	1.8	4.9	75/63	123.0	7319	7289	0.926	7.9	7552	0.863	8.7	10143
			80/67	123.8	7864	7609	0.946	8.3	8097	0.883	9.2	10759
			85/71	124.6	8436	7915	0.966	8.7	8668	0.903	9.6	11400
	2.4	8.8	75/63	119.8	7411	7334	0.908	8.2	7643	0.853	9.0	10172
			80/67	120.4	7968	7656	0.926	8.6	8201	0.871	9.4	10805
			85/71	121.0	8553	7963	0.944	9.1	8786	0.889	9.9	11455

# Heating Capacity Data – Vertical Unit Size 009

EWT	GPM	WPD	System Heating				ISO System Heating				
			EA	LWT	TOT	kW	COP	TOT	kW	COP	THA
20	1.3	2.6	60	12.8	6286	0.598	3.08	6053	0.532	3.33	4574
			70	13.1	6270	0.654	2.81	6038	0.588	3.01	4369
			80	13.5	6242	0.710	2.57	6009	0.644	2.73	4162
	1.8	4.9	60	14.6	6460	0.605	3.13	6228	0.542	3.36	4729
			70	14.9	6429	0.661	2.85	6196	0.598	3.03	4513
			80	15.1	6395	0.717	2.61	6162	0.654	2.76	4295
	2.4	8.8	60	15.9	6584	0.610	3.16	6351	0.555	3.35	4839
			70	16.1	6544	0.666	2.88	6311	0.611	3.02	4614
			80	16.3	6503	0.722	2.64	6271	0.667	2.75	4388
30	1.3	2.6	60	21.5	7213	0.635	3.33	6980	0.569	3.59	5401
			70	21.9	7179	0.693	3.03	6946	0.627	3.24	5173
			80	22.2	7143	0.752	2.78	6911	0.686	2.95	4939
	1.8	4.9	60	23.6	7438	0.644	3.38	7206	0.581	3.63	5602
			70	23.9	7391	0.702	3.08	7159	0.639	3.28	5358
			80	24.2	7337	0.761	2.82	7105	0.698	2.98	5113
	2.4	8.8	60	25.1	7596	0.650	3.42	7364	0.595	3.62	5745
			70	25.3	7534	0.708	3.12	7302	0.653	3.27	5491
			80	25.5	7477	0.767	2.85	7244	0.712	2.98	5235
40	1.3	2.6	60	30.0	8245	0.675	3.58	8012	0.609	3.85	6324
			70	30.4	8190	0.735	3.26	7957	0.669	3.48	6069
			80	30.8	8139	0.797	2.99	7906	0.731	3.17	5810
	1.8	4.9	60	32.5	8531	0.685	3.65	8298	0.622	3.90	6581
			70	32.8	8461	0.746	3.32	8229	0.683	3.53	6312
			80	33.1	8393	0.808	3.04	8160	0.745	3.21	6031
	2.4	8.8	60	34.2	8730	0.693	3.69	8497	0.638	3.90	6766
			70	34.5	8649	0.754	3.36	8416	0.699	3.52	6476
			80	34.7	8570	0.816	3.08	8338	0.761	3.21	6186
50	1.3	2.6	60	38.4	9371	0.717	3.83	9138	0.651	4.11	7335
			70	38.8	9301	0.780	3.49	9069	0.714	3.72	7053
			80	39.3	9229	0.845	3.20	8996	0.779	3.38	6765
	1.8	4.9	60	41.2	9726	0.730	3.90	9493	0.667	4.16	7653
			70	41.6	9628	0.793	3.55	9395	0.730	3.77	7351
			80	41.9	9537	0.859	3.25	9304	0.796	3.42	7041
	2.4	8.8	60	43.2	9976	0.739	3.95	9743	0.684	4.17	7880
			70	43.5	9869	0.802	3.60	9636	0.747	3.78	7563
			80	43.8	9765	0.869	3.29	9532	0.814	3.43	7239
60	1.3	2.6	60	46.6	10585	0.762	4.07	10353	0.696	4.36	8424
			70	47.1	10495	0.827	3.72	10262	0.761	3.95	8115
			80	47.6	10406	0.897	3.40	10173	0.831	3.58	7794
	1.8	4.9	60	49.9	11024	0.778	4.15	10792	0.715	4.42	8816
			70	50.3	10902	0.844	3.78	10669	0.781	4.00	8477
			80	50.7	10784	0.914	3.45	10551	0.851	3.63	8137
	2.4	8.8	60	52.2	11322	0.789	4.20	11090	0.734	4.42	9088
			70	52.5	11185	0.855	3.83	10952	0.800	4.01	8734
			80	52.8	11059	0.926	3.50	10827	0.871	3.64	8370
70	1.3	2.6	60	54.7	11888	0.810	4.30	11655	0.744	4.59	9591
			70	55.3	11764	0.878	3.92	11531	0.812	4.16	9249
			80	55.8	11658	0.952	3.59	11426	0.886	3.78	8889
	1.8	4.9	60	58.4	12395	0.829	4.38	12163	0.766	4.65	10053
			70	58.9	12257	0.898	4.00	12024	0.835	4.21	9682
			80	59.3	12121	0.973	3.65	11888	0.910	3.82	9298
	2.4	8.8	60	61.0	12764	0.842	4.44	12531	0.787	4.66	10379
			70	61.4	12596	0.912	4.04	12364	0.857	4.22	9990
			80	61.7	12443	0.987	3.69	12211	0.932	3.84	9580
80	1.3	2.6	60	62.8	13253	0.860	4.51	13020	0.794	4.80	10817
			70	63.4	13123	0.933	4.12	12891	0.867	4.35	10440
			80	64.0	12977	1.012	3.75	12745	0.946	3.94	10049
	1.8	4.9	60	66.9	13859	0.883	4.60	13627	0.820	4.86	11363
			70	67.4	13687	0.957	4.19	13454	0.894	4.40	10947
			80	67.9	13521	1.037	3.82	13289	0.974	3.99	10523
	2.4	8.8	60	69.8	14275	0.899	4.65	14042	0.844	4.87	11746
			70	70.2	14095	0.974	4.24	13862	0.919	4.42	11310
			80	70.6	13924	1.055	3.86	13691	1.000	4.01	10855
85	1.3	2.6	60	66.7	13962	0.887	4.61	13730	0.821	4.90	11451
			70	67.4	13814	0.962	4.20	13582	0.896	4.44	11056
			80	68.0	13678	1.044	3.84	13445	0.978	4.03	10645
	1.8	4.9	60	71.1	14618	0.912	4.69	14385	0.849	4.96	12040
			70	71.6	14438	0.988	4.28	14206	0.925	4.49	11600
			80	72.1	14258	1.071	3.90	14026	1.008	4.07	11155
	2.4	8.8	60	74.2	15069	0.929	4.75	14836	0.874	4.97	12451
			70	74.6	14863	1.006	4.33	14630	0.951	4.50	11992
			80	75.0	14672	1.090	3.94	14439	1.035	4.08	11516
90	1.3	2.6	60	70.7	14687	0.915	4.70	14455	0.849	4.99	12097
			70	71.3	14527	0.992	4.29	14294	0.926	4.52	11683
			80	72.0	14383	1.076	3.91	14150	1.010	4.10	11252
	1.8	4.9	60	75.3	15393	0.942	4.78	15160	0.879	5.05	12731
			70	75.8	15199	1.020	4.36	14966	0.957	4.58	12278
			80	76.4	14998	1.106	3.97	14765	1.043	4.14	11795
	2.4	8.8	60	78.6	15872	0.961	4.84	15640	0.906	5.05	13169
			70	79.0	15661	1.040	4.41	15428	0.985	4.59	12688
			80	79.4	15444	1.127	4.01	15211	1.072	4.15	12186

# Cooling Capacity Data – Vertical Unit Size 012

EWT	GPM	WPD	System Cooling						ISO System Cooling			
			EA	LWT	TOT	SEN	kW	EER	TOT	kW	EER	THR
30	1.7	5.3	75/63	49.0	12457	10995	0.601	20.7	12628	0.557	22.7	14419
			80/67	50.3	13326	11380	0.620	21.5	13498	0.576	23.5	15367
			85/71	51.6	14225	11738	0.640	22.2	14396	0.596	24.2	16343
	2.4	10.7	75/63	43.5	12635	11081	0.572	22.1	12806	0.538	23.8	14510
			80/67	44.5	13525	11468	0.589	23.0	13696	0.555	24.7	15481
			85/71	45.4	14451	11830	0.607	23.8	14623	0.573	25.5	16469
	3.3	20.2	75/63	39.9	12753	11138	0.553	23.1	12924	0.545	23.7	14583
			80/67	40.5	13658	11527	0.569	24.0	13829	0.561	24.7	15549
			85/71	41.2	14603	11892	0.586	24.9	14774	0.578	25.6	16559
40	1.7	5.3	75/63	58.8	12110	10827	0.656	18.5	12281	0.612	20.1	14228
			80/67	60.0	12964	11219	0.675	19.2	13135	0.631	20.8	15157
			85/71	61.3	13837	11580	0.695	19.9	14008	0.651	21.5	16113
	2.4	10.7	75/63	53.4	12290	10914	0.627	19.6	12461	0.593	21.0	14331
			80/67	54.3	13166	11309	0.645	20.4	13337	0.611	21.8	15273
			85/71	55.2	14066	11673	0.662	21.2	14237	0.628	22.7	16251
	3.3	20.2	75/63	49.8	12408	10972	0.608	20.4	12579	0.600	21.0	14392
			80/67	50.4	13297	11366	0.624	21.3	13468	0.616	21.9	15347
			85/71	51.1	14217	11735	0.641	22.2	14388	0.633	22.7	16343
50	1.7	5.3	75/63	68.6	11745	10651	0.715	16.4	11916	0.671	17.8	14052
			80/67	69.8	12567	11043	0.734	17.1	12738	0.690	18.5	14935
			85/71	71.0	13426	11414	0.754	17.8	13598	0.710	19.2	15873
	2.4	10.7	75/63	63.3	11931	10740	0.686	17.4	12102	0.652	18.6	14134
			80/67	64.1	12771	11133	0.703	18.2	12942	0.669	19.3	15055
			85/71	65.0	13659	11509	0.721	18.9	13830	0.687	20.1	16012
	3.3	20.2	75/63	59.7	12046	10796	0.667	18.1	12217	0.659	18.5	14208
			80/67	60.3	12906	11193	0.683	18.9	13077	0.675	19.4	15130
			85/71	61.0	13810	11569	0.699	19.8	13981	0.691	20.2	16105
60	1.7	5.3	75/63	78.4	11361	10466	0.776	14.6	11532	0.732	15.8	13826
			80/67	79.5	12159	10864	0.796	15.3	12330	0.752	16.4	14708
			85/71	80.8	12999	11242	0.817	15.9	13170	0.773	17.0	15626
	2.4	10.7	75/63	73.1	11542	10553	0.747	15.5	11713	0.713	16.4	13928
			80/67	73.9	12365	10954	0.765	16.2	12536	0.731	17.1	14819
			85/71	74.8	13229	11335	0.783	16.9	13401	0.749	17.9	15766
	3.3	20.2	75/63	69.6	11663	10612	0.728	16.0	11834	0.720	16.4	13998
			80/67	70.2	12500	11014	0.744	16.8	12671	0.736	17.2	14897
			85/71	70.8	13380	11396	0.761	17.6	13551	0.753	18.0	15858
70	1.7	5.3	75/63	88.1	10960	10273	0.842	13.0	11131	0.798	14.0	13629
			80/67	89.3	11738	10678	0.863	13.6	11909	0.819	14.5	14486
			85/71	90.5	12551	11063	0.884	14.2	12722	0.840	15.2	15376
	2.4	10.7	75/63	82.9	11142	10360	0.812	13.7	11313	0.778	14.5	13724
			80/67	83.8	11942	10768	0.830	14.4	12113	0.796	15.2	14609
			85/71	84.6	12783	11155	0.849	15.1	12954	0.815	15.9	15513
	3.3	20.2	75/63	79.5	11261	10418	0.793	14.2	11432	0.785	14.6	13799
			80/67	80.1	12078	10827	0.809	14.9	12249	0.801	15.3	14677
			85/71	80.7	12934	11217	0.826	15.7	13106	0.818	16.0	15591
80	1.7	5.3	75/63	97.9	10546	10073	0.911	11.6	10717	0.867	12.4	13413
			80/67	99.0	11300	10483	0.933	12.1	11471	0.889	12.9	14254
			85/71	100.2	12079	10872	0.955	12.6	12250	0.911	13.5	15123
	2.4	10.7	75/63	92.8	10728	10161	0.881	12.2	10900	0.847	12.9	13507
			80/67	93.5	11504	10574	0.900	12.8	11675	0.866	13.5	14349
			85/71	94.4	12317	10969	0.919	13.4	12488	0.885	14.1	15239
	3.3	20.2	75/63	89.3	10854	10222	0.861	12.6	11025	0.853	12.9	13570
			80/67	89.9	11640	10634	0.878	13.3	11811	0.870	13.6	14442
			85/71	90.5	12471	11030	0.896	13.9	12642	0.888	14.2	15326
85	1.7	5.3	75/63	102.8	10335	9971	0.947	10.9	10507	0.903	11.6	13305
			80/67	103.9	11076	10385	0.970	11.4	11247	0.926	12.2	14139
			85/71	105.0	11841	10776	0.992	11.9	12012	0.948	12.7	14981
	2.4	10.7	75/63	97.7	10516	10058	0.916	11.5	10687	0.882	12.1	13397
			80/67	98.5	11280	10476	0.936	12.1	11451	0.902	12.7	14251
			85/71	99.3	12081	10873	0.956	12.6	12252	0.922	13.3	15107
	3.3	20.2	75/63	94.2	10636	10116	0.896	11.9	10807	0.888	12.2	13459
			80/67	94.8	11415	10534	0.914	12.5	11587	0.906	12.8	14309
			85/71	95.4	12233	10934	0.932	13.1	12404	0.924	13.4	15192
90	1.7	5.3	75/63	107.6	10122	9867	0.985	10.3	10293	0.941	10.9	13196
			80/67	108.7	10849	10285	1.008	10.8	11020	0.964	11.4	14024
			85/71	109.8	11597	10678	1.031	11.2	11768	0.987	11.9	14849
	2.4	10.7	75/63	102.6	10301	9954	0.953	10.8	10472	0.919	11.4	13288
			80/67	103.3	11053	10375	0.974	11.3	11224	0.940	11.9	14117
			85/71	104.2	11829	10772	0.994	11.9	12000	0.960	12.5	14975
	3.3	20.2	75/63	99.2	10421	10012	0.933	11.2	10592	0.925	11.5	13349
			80/67	99.8	11187	10434	0.951	11.8	11358	0.943	12.0	14188
			85/71	100.4	11982	10833	0.970	12.4	12153	0.962	12.6	15058
100	1.7	5.3	75/63	117.4	9675	9649	1.063	9.1	9846	1.019	9.7	13004
			80/67	118.4	10385	10078	1.087	9.6	10557	1.043	10.1	13776
			85/71	119.5	11101	10477	1.112	10.0	11272	1.068	10.6	14587
	2.4	10.7	75/63	112.4	9864	9742	1.031	9.6	10035	0.997	10.1	13092
			80/67	113.1	10589	10169	1.052	10.1	10760	1.018	10.6	13878
			85/71	113.9	11333	10571	1.074	10.6	11504	1.040	11.1	14706
	3.3	20.2	75/63	109.0	9982	9798	1.009	9.9	10153	1.001	10.1	13134
			80/67	109.6	10722	10228	1.029	10.4	10893	1.021	10.7	13946
			85/71	110.2	11484	10632	1.049	10.9	11655	1.041	11.2	14789
110	1.7	5.3	75/63	127.1	9237	9432	1.146	8.1	9408	1.102	8.5	12786
			80/67	128.2	9894	9856	1.172	8.4	10066	1.128	8.9	13541
			85/71	129.2	10588	10266	1.199	8.8	10759	1.155	9.3	14325
	2.4	10.7	75/63	122.2	9417	9521	1.113	8.5	9588	1.079	8.9	12866
			80/67	122.9	10101	9949	1.136	8.9	10272	1.102	9.3	13640
			85/71	123.7	10822	10362	1.159	9.3	10993	1.125	9.8	14443
	3.3	20.2	75/63	118.9	9532	9578	1.091	8.7	9703	1.083	9.0	12924
			80/67	119.5	10235	10009	1.112	9.2	10406	1.104	9.4	13705
			85/71	120.0	10972	10424	1.134	9.7	11144	1.126	9.9	14520

# Heating Capacity Data – Vertical Unit Size 012

EWT	GPM	WPD	System Heating				ISO System Heating				
			EA	LWT	TOT	kW	COP	TOT	kW	COP	THA
20	1.7	5.3	60	13.0	7978	0.731	3.20	7807	0.687	3.33	5868
			70	13.3	7942	0.798	2.91	7770	0.754	3.02	5603
			80	13.6	7894	0.865	2.67	7723	0.821	2.76	5341
	2.4	10.7	60	14.9	8209	0.74	3.25	8038	0.706	3.33	6072
			70	15.1	8151	0.806	2.96	7980	0.772	3.03	5797
			80	15.3	8099	0.874	2.71	7928	0.840	2.76	5519
	3.3	20.2	60	16.2	8377	0.746	3.29	8206	0.738	3.26	6223
			70	16.4	8309	0.813	2.99	8138	0.805	2.96	5936
			80	16.5	8247	0.881	2.74	8076	0.873	2.71	5647
30	1.7	5.3	60	21.7	9152	0.774	3.46	8981	0.730	3.60	6930
			70	22.1	9105	0.845	3.15	8934	0.801	3.27	6641
			80	22.4	9053	0.917	2.89	8882	0.873	2.98	6347
	2.4	10.7	60	23.9	9459	0.785	3.53	9287	0.751	3.62	7201
			70	24.2	9389	0.856	3.21	9218	0.822	3.28	6890
			80	24.4	9313	0.929	2.94	9141	0.895	2.99	6576
	3.3	20.2	60	25.4	9675	0.793	3.57	9504	0.785	3.55	7398
			70	25.6	9593	0.864	3.25	9422	0.856	3.22	7072
			80	25.8	9505	0.937	2.97	9334	0.929	2.94	6744
40	1.7	5.3	60	30.2	10478	0.822	3.73	10307	0.778	3.88	8127
			70	30.6	10408	0.896	3.40	10237	0.852	3.52	7799
			80	31.0	10324	0.973	3.11	10153	0.929	3.20	7469
	2.4	10.7	60	32.8	10863	0.835	3.81	10692	0.801	3.91	8470
			70	33.1	10767	0.91	3.46	10596	0.876	3.54	8123
			80	33.4	10674	0.988	3.16	10503	0.954	3.22	7771
	3.3	20.2	60	34.6	11136	0.845	3.86	10965	0.837	3.84	8725
			70	34.8	11026	0.92	3.51	10854	0.912	3.49	8353
			80	35.1	10919	0.998	3.20	10748	0.990	3.18	7981
50	1.7	5.3	60	38.6	11928	0.873	4.00	11757	0.829	4.15	9433
			70	39.1	11838	0.951	3.64	11667	0.907	3.77	9077
			80	39.5	11741	1.033	3.33	11570	0.989	3.43	8704
	2.4	10.7	60	41.6	12406	0.89	4.08	12235	0.856	4.19	9870
			70	41.9	12282	0.968	3.72	12111	0.934	3.80	9477
			80	42.3	12158	1.051	3.39	11987	1.017	3.45	9077
	3.3	20.2	60	43.7	12749	0.902	4.14	12578	0.894	4.12	10176
			70	43.9	12605	0.981	3.76	12434	0.973	3.74	9768
			80	44.2	12465	1.064	3.43	12294	1.056	3.41	9350
60	1.7	5.3	60	46.9	13498	0.929	4.25	13327	0.885	4.41	10848
			70	47.4	13379	1.011	3.87	13207	0.967	4.00	10454
			80	47.9	13254	1.097	3.54	13083	1.053	3.64	10041
	2.4	10.7	60	50.3	14078	0.949	4.34	13907	0.915	4.45	11379
			70	50.6	13937	1.032	3.95	13766	0.998	4.04	10940
			80	51.0	13769	1.118	3.61	13597	1.084	3.67	10501
	3.3	20.2	60	52.7	14497	0.964	4.40	14326	0.956	4.39	11752
			70	53.0	14313	1.047	4.00	14142	1.039	3.99	11295
			80	53.3	14144	1.134	3.65	13973	1.126	3.63	10827
70	1.7	5.3	60	55.0	15184	0.988	4.50	15013	0.944	4.66	12364
			70	55.6	15018	1.074	4.09	14847	1.030	4.22	11927
			80	56.1	14872	1.165	3.74	14701	1.121	3.84	11462
	2.4	10.7	60	58.9	15862	1.013	4.58	15691	0.979	4.69	12984
			70	59.3	15669	1.099	4.17	15498	1.065	4.26	12506
			80	59.7	15491	1.191	3.81	15320	1.157	3.88	12018
	3.3	20.2	60	61.6	16370	1.031	4.65	16199	1.023	4.64	13437
			70	61.9	16146	1.117	4.23	15975	1.109	4.22	12933
			80	62.3	15935	1.21	3.86	15764	1.202	3.84	12407
80	1.7	5.3	60	63.1	16951	1.051	4.72	16780	1.007	4.88	13958
			70	63.7	16768	1.141	4.30	16597	1.097	4.43	13469
			80	64.3	16569	1.236	3.93	16398	1.192	4.03	12973
	2.4	10.7	60	67.4	17760	1.081	4.81	17589	1.047	4.92	14680
			70	67.8	17525	1.171	4.38	17354	1.137	4.47	14155
			80	68.3	17306	1.267	4.00	17135	1.233	4.07	13611
	3.3	20.2	60	70.5	18336	1.101	4.88	18165	1.093	4.87	15224
			70	70.8	18087	1.193	4.44	17916	1.185	4.43	14660
			80	71.2	17846	1.29	4.05	17675	1.282	4.04	14075
85	1.7	5.3	60	67.1	17862	1.084	4.82	17691	1.040	4.98	14777
			70	67.7	17658	1.176	4.40	17487	1.132	4.53	14269
			80	68.3	17469	1.274	4.02	17298	1.230	4.12	13745
	2.4	10.7	60	71.6	18743	1.116	4.92	18572	1.082	5.03	15575
			70	72.1	18480	1.208	4.48	18309	1.174	4.57	15020
			80	72.6	18243	1.307	4.09	18072	1.273	4.16	14436
	3.3	20.2	60	74.9	19369	1.139	4.98	19198	1.131	4.97	16147
			70	75.3	19084	1.232	4.54	18913	1.224	4.53	15554
			80	75.7	18813	1.331	4.14	18642	1.323	4.13	14940
90	1.7	5.3	60	71.0	18797	1.118	4.92	18626	1.074	5.08	15616
			70	71.7	18576	1.212	4.49	18405	1.168	4.62	15086
			80	72.4	18357	1.312	4.10	18186	1.268	4.20	14532
	2.4	10.7	60	75.8	19747	1.152	5.02	19575	1.118	5.13	16476
			70	76.3	19477	1.247	4.57	19306	1.213	4.66	15891
			80	76.9	19199	1.348	4.17	19028	1.314	4.24	15275
	3.3	20.2	60	79.3	20412	1.177	5.08	20241	1.169	5.07	17087
			70	79.7	20115	1.272	4.63	19944	1.264	4.62	16466
			80	80.1	19807	1.374	4.22	19636	1.366	4.21	15819

# Cooling Capacity Data – Vertical Unit Size 019

EWT	GPM	WPD	System Cooling						ISO System Cooling			
			EA	LWT	TOT	SEN	kW	EER	TOT	kW	EER	THR
30	2.7	2.5	75/63	51.8	24635	17679	1.125	21.9	25241	0.952	26.5	28656
			80/67	53.3	26625	18270	1.106	24.1	27232	0.933	29.2	30610
			85/71	54.9	28742	18813	1.081	26.6	29349	0.908	32.3	32689
	3.9	5.2	75/63	45.6	25769	18219	1.070	24.1	26375	0.905	29.1	29637
			80/67	46.7	27896	18828	1.040	26.8	28503	0.875	32.6	31690
			85/71	47.8	30173	19390	1.002	30.1	30779	0.837	36.8	33886
	5.2	9.2	75/63	41.9	26476	18559	1.039	25.5	27083	0.891	30.4	30261
			80/67	42.8	28692	19181	1.003	28.6	29299	0.855	34.2	32382
			85/71	43.7	31064	19755	0.958	32.4	31670	0.810	39.1	34666
40	2.7	2.5	75/63	60.9	23184	17000	1.205	19.2	23790	1.032	23.1	27431
			80/67	62.4	25117	17618	1.194	21.0	25724	1.021	25.2	29359
			85/71	63.9	27169	18189	1.177	23.1	27776	1.004	27.7	31382
	3.9	5.2	75/63	54.9	24229	17489	1.147	21.1	24836	0.982	25.3	28301
			80/67	56.0	26281	18120	1.125	23.4	26888	0.960	28.0	30331
			85/71	57.1	28461	18700	1.096	26.0	29067	0.931	31.2	32491
	5.2	9.2	75/63	51.4	24860	17786	1.114	22.3	25467	0.966	26.3	28859
			80/67	52.2	26997	18432	1.086	24.9	27603	0.938	29.4	30939
			85/71	53.1	29291	19033	1.050	27.9	29897	0.902	33.1	33157
50	2.7	2.5	75/63	70.1	21765	16347	1.293	16.8	22371	1.120	20.0	26280
			80/67	71.5	23611	16978	1.290	18.3	24217	1.117	21.7	28155
			85/71	73.0	25557	17560	1.282	19.9	26164	1.109	23.6	30099
	3.9	5.2	75/63	64.3	22711	16781	1.234	18.4	23318	1.069	21.8	27048
			80/67	65.3	24679	17431	1.221	20.2	25285	1.056	23.9	29004
			85/71	66.4	26777	18035	1.201	22.3	27384	1.036	26.4	31091
	5.2	9.2	75/63	60.9	23264	17037	1.200	19.4	23870	1.052	22.7	27519
			80/67	61.7	25328	17708	1.181	21.4	25934	1.033	25.1	29522
			85/71	62.6	27509	18323	1.154	23.8	28116	1.006	27.9	31698
60	2.7	2.5	75/63	79.3	20353	15707	1.387	14.7	20960	1.214	17.3	25150
			80/67	80.7	22120	16356	1.393	15.9	22727	1.220	18.6	26971
			85/71	82.1	23972	16953	1.394	17.2	24578	1.221	20.1	28861
	3.9	5.2	75/63	73.7	21214	16096	1.329	16.0	21820	1.164	18.7	25850
			80/67	74.7	23095	16762	1.325	17.4	23702	1.160	20.4	27741
			85/71	75.8	25093	17381	1.314	19.1	25699	1.149	22.4	29725
	5.2	9.2	75/63	70.4	21725	16329	1.295	16.8	22332	1.147	19.5	26251
			80/67	71.2	23690	17012	1.285	18.4	24297	1.137	21.4	28225
			85/71	72.0	25768	17642	1.268	20.3	26374	1.120	23.5	30266
70	2.7	2.5	75/63	88.4	18964	15086	1.485	12.8	19570	1.312	14.9	24035
			80/67	89.8	20622	15740	1.500	13.7	21228	1.327	16.0	25780
			85/71	91.2	22390	16356	1.510	14.8	22996	1.337	17.2	27633
	3.9	5.2	75/63	83.1	19746	15435	1.429	13.8	20352	1.264	16.1	24653
			80/67	84.1	21534	16114	1.434	15.0	22141	1.269	17.4	26513
			85/71	85.1	23428	16747	1.433	16.3	24034	1.268	19.0	28399
	5.2	9.2	75/63	80.0	20209	15643	1.397	14.5	20816	1.249	16.7	25013
			80/67	80.7	22076	16338	1.396	15.8	22683	1.248	18.2	26925
			85/71	81.5	24044	16980	1.389	17.3	24650	1.241	19.9	28933
80	2.7	2.5	75/63	97.6	17562	14468	1.583	11.1	18169	1.410	12.9	22941
			80/67	98.9	19142	15139	1.607	11.9	19748	1.434	13.8	24646
			85/71	100.3	20815	15771	1.626	12.8	21421	1.453	14.7	26390
	3.9	5.2	75/63	92.4	18341	14811	1.529	12.0	18948	1.364	13.9	23550
			80/67	93.4	19996	15485	1.545	12.9	20602	1.380	14.9	25286
			85/71	94.4	21784	16131	1.555	14.0	22391	1.390	16.1	27146
	5.2	9.2	75/63	89.5	18731	14984	1.501	12.5	19338	1.353	14.3	23860
			80/67	90.2	20479	15682	1.510	13.6	21085	1.362	15.5	25667
			85/71	91.0	22350	16341	1.513	14.8	22956	1.365	16.8	27591
85	2.7	2.5	75/63	102.2	16865	14162	1.632	10.3	17471	1.459	12.0	22379
			80/67	103.5	18402	14841	1.660	11.1	19009	1.487	12.8	24049
			85/71	104.8	20007	15473	1.685	11.9	20614	1.512	13.6	25772
	3.9	5.2	75/63	97.2	17577	14473	1.582	11.1	18183	1.417	12.8	22950
			80/67	98.1	19216	15168	1.602	12.0	19822	1.437	13.8	24690
			85/71	99.1	20963	15825	1.616	13.0	21569	1.451	14.9	26505
	5.2	9.2	75/63	94.3	17988	14655	1.553	11.6	18594	1.405	13.2	23278
			80/67	95.0	19692	15361	1.567	12.6	20298	1.419	14.3	25068
			85/71	95.7	21513	16030	1.575	13.7	22119	1.427	15.5	26934
90	2.7	2.5	75/63	106.8	16171	13858	1.680	9.6	16777	1.507	11.1	21829
			80/67	108.1	17663	14544	1.713	10.3	18270	1.540	11.9	23466
			85/71	109.4	19215	15182	1.742	11.0	19821	1.569	12.6	25150
	3.9	5.2	75/63	101.9	16854	14157	1.633	10.3	17460	1.468	11.9	22378
			80/67	102.8	18448	14860	1.657	11.1	19055	1.492	12.8	24085
			85/71	103.8	20124	15516	1.676	12.0	20730	1.511	13.7	25863
	5.2	9.2	75/63	99.1	17266	14337	1.605	10.8	17873	1.457	12.3	22697
			80/67	99.8	18908	15045	1.624	11.6	19514	1.476	13.2	24448
			85/71	100.5	20656	15712	1.637	12.6	21263	1.489	14.3	26278
100	2.7	2.5	75/63	116.0	14792	13250	1.773	8.3	15398	1.600	9.6	20733
			80/67	117.2	16166	13944	1.815	8.9	16772	1.642	10.2	22282
			85/71	118.4	17621	14600	1.854	9.5	18227	1.681	10.8	23888
	3.9	5.2	75/63	111.3	15421	13528	1.731	8.9	16027	1.566	10.2	21243
			80/67	112.2	16901	14238	1.765	9.6	17507	1.600	10.9	22868
			85/71	113.1	18474	14911	1.795	10.3	19080	1.630	11.7	24565
	5.2	9.2	75/63	108.6	15792	13690	1.706	9.3	16399	1.558	10.5	21540
			80/67	109.3	17347	14418	1.735	10.0	17953	1.587	11.3	23212
			85/71	110.0	18972	15093	1.759	10.8	19578	1.611	12.1	24958
110	2.7	2.5	75/63	125.1	13397	12624	1.860	7.2	14004	1.687	8.3	19601
			80/67	126.3	14674	13339	1.912	7.7	15281	1.739	8.8	21071
			85/71	127.5	16022	14014	1.960	8.2	16628	1.787	9.3	22618
	3.9	5.2	75/63	120.7	13987	12893	1.823	7.7	14594	1.658	8.8	20086
			80/67	121.6	15361	13619	1.868	8.2	15968	1.703	9.4	21633
			85/71	122.4	16817	14306	1.908	8.8	17423	1.743	10.0	23243
	5.2	9.2	75/63	118.2	14342	13051	1.802	8.0	14948	1.654	9.0	20366
			80/67	118.8	15764	13782	1.842	8.6	16370	1.694	9.7	21957
			85/71	119.5	17283	14476	1.877	9.2	17889	1.729	10.3	23617



# Heating Capacity Data – Vertical Unit Size 019

EWT	GPM	WPD	System Heating				ISO System Heating				
			EA	LWT	TOT	kW	COP	TOT	kW	COP	THA
20	2.7	2.5	60	13.8	12052	1.180	2.99	11446	1.007	3.33	8531
			70	14.4	11310	1.209	2.74	10704	1.036	3.03	7676
			80	15.0	10569	1.238	2.49	9962	1.065	2.74	6821
	3.9	5.2	60	15.4	12577	1.202	3.06	11970	1.037	3.38	8987
			70	15.9	11772	1.230	2.80	11166	1.065	3.07	8060
			80	16.4	10967	1.258	2.54	10361	1.093	2.78	7133
	5.2	9.2	60	16.5	12908	1.215	3.11	12301	1.067	3.37	9272
			70	16.8	12058	1.244	2.84	11452	1.096	3.06	8305
			80	17.1	11208	1.273	2.57	10602	1.125	2.76	7338
30	2.7	2.5	60	22.2	14407	1.274	3.31	13801	1.101	3.67	10619
			70	22.9	13605	1.315	3.03	12998	1.142	3.33	9660
			80	23.6	12807	1.351	2.78	12201	1.178	3.03	8719
	3.9	5.2	60	24.3	15078	1.298	3.40	14471	1.133	3.74	11219
			70	24.8	14202	1.340	3.10	13596	1.175	3.39	10186
			80	25.3	13330	1.377	2.83	12724	1.212	3.07	9161
	5.2	9.2	60	25.6	15512	1.313	3.46	14905	1.165	3.74	11602
			70	26.0	14576	1.356	3.15	13969	1.208	3.38	10512
			80	26.4	13657	1.393	2.87	13050	1.245	3.07	9433
40	2.7	2.5	60	30.5	16939	1.362	3.64	16332	1.189	4.02	12894
			70	31.3	16070	1.417	3.32	15464	1.244	3.64	11829
			80	32.1	15206	1.467	3.04	14600	1.294	3.30	10776
	3.9	5.2	60	33.0	17780	1.389	3.75	17174	1.224	4.11	13665
			70	33.6	16823	1.446	3.41	16217	1.281	3.71	12501
			80	34.2	15875	1.498	3.10	15269	1.333	3.35	11354
	5.2	9.2	60	34.6	18313	1.405	3.82	17706	1.257	4.12	14154
			70	35.1	17300	1.463	3.46	16694	1.315	3.72	12924
			80	35.5	16309	1.516	3.15	15703	1.368	3.36	11717
50	2.7	2.5	60	38.7	19619	1.443	3.98	19013	1.270	4.38	15359
			70	39.5	18699	1.513	3.62	18092	1.340	3.95	14181
			80	40.4	17764	1.579	3.29	17157	1.406	3.57	13003
	3.9	5.2	60	41.6	20656	1.471	4.11	20049	1.306	4.49	16324
			70	42.3	19638	1.545	3.72	19032	1.380	4.04	15023
			80	43.0	18596	1.613	3.38	17989	1.448	3.64	13741
	5.2	9.2	60	43.5	21310	1.489	4.19	20704	1.341	4.52	16941
			70	44.0	20228	1.564	3.79	19622	1.416	4.06	15559
			80	44.5	19120	1.634	3.43	18514	1.486	3.65	14204
60	2.7	2.5	60	46.7	22453	1.517	4.33	21847	1.344	4.76	17985
			70	47.6	21471	1.603	3.92	20865	1.430	4.27	16689
			80	48.6	20465	1.685	3.56	19858	1.512	3.85	15396
	3.9	5.2	60	50.2	23705	1.546	4.49	23099	1.381	4.90	19185
			70	50.9	22601	1.636	4.05	21995	1.471	4.38	17752
			80	51.6	21495	1.722	3.65	20888	1.557	3.93	16307
	5.2	9.2	60	52.3	24500	1.564	4.59	23894	1.416	4.94	19955
			70	52.9	23319	1.657	4.12	22713	1.509	4.41	18408
			80	53.5	22119	1.745	3.71	21512	1.597	3.94	16888
70	2.7	2.5	60	54.6	25404	1.583	4.70	24797	1.410	5.15	20787
			70	55.6	24345	1.685	4.23	23739	1.512	4.60	19364
			80	56.7	23297	1.784	3.82	22690	1.611	4.12	17931
	3.9	5.2	60	58.6	26895	1.612	4.89	26289	1.447	5.32	22233
			70	59.4	25712	1.720	4.38	25105	1.555	4.73	20643
			80	60.2	24506	1.824	3.93	23900	1.659	4.22	19054
	5.2	9.2	60	61.1	27850	1.630	5.00	27244	1.482	5.38	23142
			70	61.7	26562	1.741	4.47	25956	1.593	4.77	21454
			80	62.4	25271	1.847	4.01	24664	1.699	4.25	19746
80	2.7	2.5	60	62.4	28460	1.640	5.08	27854	1.467	5.56	23728
			70	63.5	27342	1.759	4.55	26736	1.586	4.94	22169
			80	64.7	26200	1.875	4.09	25593	1.702	4.40	20589
	3.9	5.2	60	66.9	30248	1.670	5.30	29642	1.505	5.77	25401
			70	67.8	28910	1.794	4.72	28304	1.629	5.09	23693
			80	68.7	27603	1.915	4.22	26997	1.750	4.52	21919
	5.2	9.2	60	69.8	31320	1.685	5.44	30714	1.537	5.85	26498
			70	70.5	29932	1.815	4.83	29326	1.667	5.15	24631
			80	71.2	28516	1.940	4.30	27910	1.792	4.56	22764
85	2.7	2.5	60	66.2	30049	1.666	5.28	29443	1.493	5.78	25236
			70	67.4	28868	1.793	4.71	28262	1.620	5.11	23602
			80	68.7	27658	1.917	4.22	27051	1.744	4.54	21966
	3.9	5.2	60	71.1	31913	1.693	5.52	31307	1.528	6.00	27064
			70	72.0	30568	1.827	4.90	29962	1.662	5.28	25242
			80	72.9	29212	1.958	4.37	28606	1.793	4.67	23395
	5.2	9.2	60	74.1	33109	1.709	5.67	32502	1.561	6.09	28233
			70	74.8	31653	1.848	5.02	31047	1.700	5.35	26273
			80	75.6	30172	1.982	4.46	29566	1.834	4.72	24302
90	2.7	2.5	60	70.1	31641	1.690	5.48	31035	1.517	5.99	26776
			70	71.3	30412	1.824	4.88	29805	1.651	5.29	25085
			80	72.6	29174	1.957	4.37	28568	1.784	4.69	23359
	3.9	5.2	60	75.2	33616	1.715	5.74	33010	1.550	6.24	28742
			70	76.2	32246	1.858	5.08	31640	1.693	5.47	26822
			80	77.2	30815	1.997	4.52	30209	1.832	4.83	24905
	5.2	9.2	60	78.4	34907	1.729	5.91	34301	1.581	6.35	30000
			70	79.2	33382	1.877	5.21	32776	1.729	5.55	27945
			80	80.0	31840	2.020	4.62	31234	1.872	4.88	25878

# Cooling Capacity Data – Vertical Unit Size 024

EWT	GPM	WPD	System Cooling						ISO System Cooling			
			EA	LWT	TOT	SEN	kW	EER	TOT	kW	EER	THR
30	3.4	3.9	75/63	49.5	27495	20859	1.174	23.4	28169	0.985	28.6	31646
			80/67	50.8	29692	21596	1.148	25.9	30366	0.959	31.7	33775
			85/71	52.2	32013	22276	1.119	28.6	32687	0.930	35.1	36031
	4.9	8.2	75/63	43.7	28301	21237	1.060	26.7	28975	0.888	32.6	32087
			80/67	44.6	30588	21983	1.017	30.1	31262	0.845	37.0	34260
			85/71	45.6	33026	22678	0.968	34.1	33700	0.796	42.3	36592
	6.5	14.4	75/63	40.4	28782	21464	0.991	29.0	29456	0.853	34.6	32309
			80/67	41.1	31098	22205	0.937	33.2	31771	0.799	39.8	34523
			85/71	41.9	33578	22898	0.876	38.3	34252	0.738	46.4	36883
40	3.4	3.9	75/63	59.1	26259	20282	1.334	19.7	26933	1.145	23.5	30895
			80/67	60.4	28426	21052	1.320	21.5	29100	1.131	25.7	33018
			85/71	61.8	30671	21748	1.304	23.5	31345	1.115	28.1	35265
	4.9	8.2	75/63	53.4	27073	20662	1.231	22.0	27747	1.059	26.2	31364
			80/67	54.3	29306	21429	1.202	24.4	29980	1.030	29.1	33535
			85/71	55.3	31675	22142	1.167	27.1	32349	0.995	32.5	35843
	6.5	14.4	75/63	50.2	27525	20872	1.170	23.5	28198	1.032	27.3	31660
			80/67	50.9	29818	21650	1.131	26.4	30492	0.993	30.7	33855
			85/71	51.7	32239	22365	1.085	29.7	32913	0.947	34.8	36193
50	3.4	3.9	75/63	68.6	24950	19680	1.488	16.8	25624	1.299	19.7	30059
			80/67	69.9	27043	20465	1.487	18.2	27717	1.298	21.4	32180
			85/71	71.2	29198	21175	1.481	19.7	29871	1.292	23.1	34346
	4.9	8.2	75/63	63.1	25754	20049	1.396	18.4	26427	1.224	21.6	30584
			80/67	64.0	27932	20842	1.380	20.2	28606	1.208	23.7	32712
			85/71	65.0	30222	21572	1.358	22.3	30895	1.186	26.1	34998
	6.5	14.4	75/63	60.0	26202	20256	1.341	19.5	26875	1.203	22.3	30886
			80/67	60.7	28461	21066	1.316	21.6	29134	1.178	24.7	33036
			85/71	61.4	30805	21800	1.285	24.0	31478	1.147	27.5	35355
60	3.4	3.9	75/63	78.0	23596	19061	1.634	14.4	24270	1.445	16.8	29121
			80/67	79.3	25573	19847	1.645	15.5	26247	1.456	18.0	31221
			85/71	80.7	27666	20585	1.651	16.8	28339	1.462	19.4	33336
	4.9	8.2	75/63	72.8	24374	19415	1.553	15.7	25048	1.381	18.1	29683
			80/67	73.7	26454	20217	1.549	17.1	27128	1.377	19.7	31806
			85/71	74.6	28712	20987	1.541	18.6	29386	1.369	21.5	34040
	6.5	14.4	75/63	69.7	24812	19616	1.504	16.5	25486	1.366	18.7	29990
			80/67	70.4	26989	20442	1.493	18.1	27662	1.355	20.4	32126
			85/71	71.1	29235	21189	1.476	19.8	29908	1.338	22.4	34374
70	3.4	3.9	75/63	87.5	22188	18423	1.775	12.5	22861	1.586	14.4	28140
			80/67	88.7	24074	19224	1.796	13.4	24748	1.607	15.4	30141
			85/71	90.0	26070	19979	1.814	14.4	26744	1.625	16.5	32251
	4.9	8.2	75/63	82.3	22935	18761	1.701	13.5	23609	1.529	15.4	28673
			80/67	83.2	24948	19587	1.711	14.6	25622	1.539	16.6	30761
			85/71	84.2	27060	20354	1.716	15.8	27734	1.544	18.0	32953
	6.5	14.4	75/63	79.4	23367	18957	1.658	14.1	24040	1.520	15.8	28966
			80/67	80.1	25432	19789	1.660	15.3	26106	1.522	17.2	31105
			85/71	80.8	27625	20570	1.657	16.7	28298	1.519	18.6	33343
80	3.4	3.9	75/63	96.8	20701	17753	1.908	10.8	21375	1.719	12.4	27072
			80/67	98.0	22509	18577	1.940	11.6	23183	1.751	13.2	29029
			85/71	99.3	24404	19349	1.969	12.4	25078	1.780	14.1	31026
	4.9	8.2	75/63	91.9	21441	18087	1.843	11.6	22115	1.671	13.2	27622
			80/67	92.8	23353	18926	1.864	12.5	24026	1.692	14.2	29639
			85/71	93.6	25375	19715	1.879	13.5	26048	1.707	15.3	31743
	6.5	14.4	75/63	89.1	21878	18284	1.804	12.1	22552	1.666	13.5	27915
			80/67	89.7	23835	19125	1.819	13.1	24509	1.681	14.6	29967
			85/71	90.4	25921	19922	1.828	14.2	26595	1.690	15.7	32131
85	3.4	3.9	75/63	101.5	19950	17416	1.971	10.1	20624	1.782	11.6	26499
			80/67	102.7	21706	18248	2.009	10.8	22380	1.820	12.3	28416
			85/71	103.9	23523	19018	2.044	11.5	24197	1.855	13.0	30387
	4.9	8.2	75/63	96.7	20674	17741	1.910	10.8	21348	1.738	12.3	27049
			80/67	97.5	22537	18589	1.938	11.6	23211	1.766	13.1	29061
			85/71	98.4	24501	19386	1.960	12.5	25175	1.788	14.1	31097
	6.5	14.4	75/63	93.9	21092	17930	1.874	11.3	21766	1.736	12.5	27356
			80/67	94.5	23011	18785	1.895	12.1	23684	1.757	13.5	29359
			85/71	95.2	25016	19580	1.911	13.1	25690	1.773	14.5	31483
90	3.4	3.9	75/63	106.2	19192	17074	2.034	9.4	19865	1.845	10.8	25952
			80/67	107.3	20896	17915	2.076	10.1	21570	1.887	11.4	27800
			85/71	108.5	22648	18690	2.116	10.7	23322	1.927	12.1	29727
	4.9	8.2	75/63	101.4	19894	17390	1.976	10.1	20568	1.804	11.4	26456
			80/67	102.3	21704	18247	2.009	10.8	22378	1.837	12.2	28414
			85/71	103.1	23586	19042	2.038	11.6	24260	1.866	13.0	30433
	6.5	14.4	75/63	98.7	20317	17581	1.942	10.5	20990	1.804	11.6	26771
			80/67	99.4	22176	18441	1.969	11.3	22850	1.831	12.5	28768
			85/71	100.0	24133	19248	1.991	12.1	24807	1.853	13.4	30839
100	3.4	3.9	75/63	115.4	17647	16371	2.153	8.2	18321	1.964	9.3	24735
			80/67	116.5	19211	17216	2.206	8.7	19885	2.017	9.9	26510
			85/71	117.7	20860	18019	2.256	9.2	21533	2.067	10.4	28349
	4.9	8.2	75/63	110.9	18320	16679	2.102	8.7	18994	1.930	9.8	25263
			80/67	111.7	19998	17542	2.146	9.3	20672	1.974	10.5	27122
			85/71	112.6	21765	18359	2.187	10.0	22439	2.015	11.1	29051
	6.5	14.4	75/63	108.3	18708	16855	2.072	9.0	19381	1.934	10.0	25563
			80/67	109.0	20463	17734	2.111	9.7	21136	1.973	10.7	27471
			85/71	109.6	22289	18556	2.145	10.4	22963	2.007	11.4	29452
110	3.4	3.9	75/63	124.7	16062	15625	2.266	7.1	16735	2.077	8.1	23488
			80/67	125.7	17508	16495	2.329	7.5	18182	2.140	8.5	25162
			85/71	126.8	19018	17314	2.391	8.0	19692	2.202	8.9	26918
	4.9	8.2	75/63	120.4	16703	15932	2.221	7.5	17377	2.049	8.5	24000
			80/67	121.2	18258	16816	2.276	8.0	18931	2.104	9.0	25760
			85/71	122.0	19888	17648	2.328	8.5	20562	2.156	9.5	27586
	6.5	14.4	75/63	117.9	17071	16105	2.194	7.8	17745	2.056	8.6	24291
			80/67	118.5	18687	16997	2.245	8.3	19361	2.107	9.2	26099
			85/71	119.1	20387	17838	2.292	8.9	21061	2.154	9.8	27979

# Heating Capacity Data - Vertical Unit Size 024

EWT	GPM	WPD	System Heating					ISO System Heating			
			EA	LWT	TOT	kW	COP	TOT	kW	COP	THA
20	3.4	3.9	60	14.2	14800	1.435	3.02	14126	1.246	3.32	10362
			70	14.8	13962	1.477	2.77	13288	1.288	3.02	9344
			80	15.4	13124	1.519	2.52	12450	1.330	2.74	8326
	4.9	8.2	60	15.8	15401	1.457	3.10	14728	1.285	3.36	10905
			70	16.2	14494	1.5	2.83	13820	1.328	3.05	9813
			80	16.6	13586	1.543	2.56	12913	1.371	2.76	8721
	6.5	14.4	60	16.7	15800	1.471	3.15	15126	1.353	3.32	11240
			70	17.0	14818	1.514	2.87	14145	1.376	3.01	10107
			80	17.3	13836	1.557	2.59	13163	1.419	2.72	8974
30	3.4	3.9	60	22.7	17764	1.537	3.38	17090	1.348	3.71	13032
			70	23.3	16878	1.596	3.10	16204	1.407	3.37	11919
			80	23.9	15992	1.647	2.84	15319	1.458	3.08	10829
	4.9	8.2	60	24.7	18559	1.562	3.48	17885	1.390	3.77	13753
			70	25.1	17597	1.623	3.17	16924	1.451	3.42	12561
			80	25.6	16631	1.676	2.91	15958	1.504	3.11	11380
	6.5	14.4	60	25.8	19071	1.578	3.54	18398	1.440	3.74	14209
			70	26.2	18044	1.64	3.22	17371	1.502	3.39	12953
			80	26.6	17026	1.693	2.94	16352	1.555	3.08	11712
40	3.4	3.9	60	31.0	20960	1.634	3.76	20286	1.445	4.11	15951
			70	31.7	20021	1.711	3.43	19347	1.522	3.72	14718
			80	32.4	19066	1.78	3.14	18392	1.591	3.38	13499
	4.9	8.2	60	33.4	21964	1.662	3.87	21291	1.490	4.18	16870
			70	33.9	20931	1.742	3.52	20258	1.570	3.78	15538
			80	34.5	19883	1.814	3.21	19209	1.642	3.43	14212
	6.5	14.4	60	34.9	22594	1.679	3.94	21920	1.541	4.17	17452
			70	35.3	21504	1.761	3.58	20830	1.623	3.76	16051
			80	35.7	20393	1.834	3.26	19720	1.696	3.41	14661
50	3.4	3.9	60	39.2	24330	1.726	4.13	23656	1.537	4.51	19078
			70	40.0	23360	1.822	3.75	22686	1.633	4.07	17726
			80	40.8	22323	1.911	3.42	21649	1.722	3.68	16366
	4.9	8.2	60	42.1	25602	1.758	4.26	24928	1.586	4.60	20244
			70	42.7	24491	1.858	3.86	23817	1.686	4.14	18750
			80	43.2	23338	1.95	3.50	22665	1.778	3.73	17257
	6.5	14.4	60	43.8	26360	1.777	4.34	25686	1.639	4.59	20966
			70	44.3	25194	1.88	3.92	24521	1.742	4.12	19389
			80	44.7	23961	1.973	3.56	23287	1.835	3.72	17814
60	3.4	3.9	60	47.3	27919	1.815	4.50	27245	1.626	4.91	22397
			70	48.2	26852	1.93	4.07	26178	1.741	4.40	20910
			80	49.0	25731	2.038	3.70	25057	1.849	3.97	19381
	4.9	8.2	60	50.7	29416	1.85	4.66	28743	1.678	5.02	23819
			70	51.3	28215	1.97	4.19	27541	1.798	4.49	22164
			80	52.0	26964	2.082	3.79	26291	1.910	4.03	20473
	6.5	14.4	60	52.7	30351	1.871	4.75	29678	1.733	5.02	24718
			70	53.2	29062	1.995	4.27	28388	1.857	4.48	22941
			80	53.7	27724	2.109	3.85	27050	1.971	4.02	21152
70	3.4	3.9	60	55.3	31632	1.9	4.87	30958	1.711	5.30	25900
			70	56.3	30480	2.035	4.39	29806	1.846	4.73	24235
			80	57.2	29249	2.162	3.96	28575	1.973	4.24	22547
	4.9	8.2	60	59.2	33409	1.939	5.05	32735	1.767	5.42	27580
			70	59.9	32073	2.08	4.52	31399	1.908	4.82	25732
			80	60.6	30704	2.212	4.06	30030	2.040	4.31	23849
	6.5	14.4	60	61.5	34526	1.963	5.15	33852	1.825	5.43	28638
			70	62.1	33093	2.107	4.60	32420	1.969	4.82	26670
			80	62.7	31598	2.242	4.13	30924	2.104	4.30	24647
80	3.4	3.9	60	63.2	35496	1.984	5.24	34823	1.795	5.68	29536
			70	64.3	34213	2.137	4.69	33540	1.948	5.04	27685
			80	65.4	32871	2.284	4.21	32197	2.095	4.50	25799
	4.9	8.2	60	67.6	37539	2.026	5.43	36865	1.854	5.82	31490
			70	68.4	36081	2.186	4.83	35408	2.014	5.15	29438
			80	69.2	34550	2.338	4.33	33876	2.166	4.58	27317
	6.5	14.4	60	70.3	38824	2.052	5.54	38151	1.914	5.84	32714
			70	70.9	37244	2.216	4.92	36570	2.078	5.15	30513
			80	71.6	35576	2.37	4.40	34902	2.232	4.58	28256
85	3.4	3.9	60	67.2	37464	2.024	5.42	36790	1.835	5.87	31394
			70	68.3	36115	2.187	4.84	35441	1.998	5.19	29461
			80	69.4	34706	2.343	4.34	34033	2.154	4.63	27461
	4.9	8.2	60	71.8	39633	2.067	5.61	38959	1.895	6.02	33487
			70	72.7	38136	2.238	4.99	37463	2.066	5.31	31323
			80	73.5	36495	2.399	4.45	35821	2.227	4.71	29101
	6.5	14.4	60	74.7	41016	2.094	5.74	40342	1.956	6.04	34796
			70	75.4	39334	2.268	5.08	38660	2.130	5.32	32472
			80	76.1	37561	2.432	4.52	36887	2.294	4.71	30091
90	3.4	3.9	60	71.1	39453	2.064	5.60	38780	1.875	6.06	33275
			70	72.2	38030	2.236	4.98	37356	2.047	5.34	31254
			80	73.4	36554	2.401	4.46	35880	2.212	4.75	29135
	4.9	8.2	60	76.0	41766	2.109	5.80	41093	1.937	6.21	35505
			70	76.9	40158	2.288	5.14	39484	2.116	5.46	33229
			80	77.8	38440	2.458	4.58	37766	2.286	4.84	30899
	6.5	14.4	60	79.0	43256	2.137	5.93	42582	1.999	6.24	36891
			70	79.8	41452	2.319	5.23	40778	2.181	5.48	34450
			80	80.5	39582	2.492	4.65	38908	2.354	4.84	31940

# Cooling Capacity Data – Vertical Unit Size 030

EWT	GPM	WPD	System Cooling						ISO System Cooling			
			EA	LWT	TOT	SEN	kW	EER	TOT	kW	EER	THR
30	4.3	2.3	75/63	47.4	33513	24710	1.252	26.8	34261	1.039	33.0	38110
			80/67	48.6	35964	25549	1.265	28.4	36712	1.052	34.9	40663
			85/71	49.8	38523	26326	1.280	30.1	39271	1.067	36.8	43315
	6.1	4.6	75/63	42.3	34019	24929	1.134	30.0	34768	0.932	37.3	38220
			80/67	43.1	36552	25783	1.137	32.1	37300	0.935	39.9	40823
			85/71	44.0	39201	26572	1.144	34.3	39949	0.942	42.4	43544
	8.1	8.2	75/63	39.3	34318	25057	1.059	32.4	35067	0.882	39.8	38258
			80/67	39.9	36891	25917	1.056	34.9	37639	0.879	42.8	40886
			85/71	40.6	39583	26712	1.057	37.4	40331	0.880	45.9	43675
40	4.3	2.3	75/63	57.3	32535	24291	1.458	22.3	33283	1.245	26.7	37835
			80/67	58.5	34898	25130	1.471	23.7	35647	1.258	28.3	40288
			85/71	59.6	37388	25917	1.486	25.2	38136	1.273	30.0	42868
	6.1	4.6	75/63	52.3	33052	24512	1.353	24.4	33801	1.151	29.4	37994
			80/67	53.1	35520	25374	1.358	26.2	36268	1.156	31.4	40508
			85/71	53.9	38071	26163	1.365	27.9	38819	1.163	33.4	43157
	8.1	8.2	75/63	49.3	33355	24643	1.288	25.9	34104	1.111	30.7	38092
			80/67	49.9	35857	25507	1.288	27.8	36605	1.111	33.0	40623
			85/71	50.5	38473	26308	1.290	29.8	39221	1.113	35.3	43313
50	4.3	2.3	75/63	67.2	31497	23848	1.654	19.0	32245	1.441	22.4	37469
			80/67	68.3	33781	24692	1.667	20.3	34530	1.454	23.7	39816
			85/71	69.4	36193	25489	1.685	21.5	36942	1.472	25.1	42330
	6.1	4.6	75/63	62.2	32042	24079	1.556	20.6	32790	1.354	24.2	37629
			80/67	63.0	34378	24925	1.564	22.0	35127	1.362	25.8	40114
			85/71	63.8	36875	25734	1.574	23.4	37624	1.372	27.4	42661
	8.1	8.2	75/63	59.2	32355	24214	1.498	21.6	33104	1.321	25.1	37765
			80/67	59.8	34739	25067	1.500	23.2	35487	1.323	26.8	40224
			85/71	60.4	37285	25881	1.505	24.8	38033	1.328	28.6	42852
60	4.3	2.3	75/63	77.0	30397	23382	1.847	16.5	31146	1.634	19.1	37012
			80/67	78.1	32605	24234	1.863	17.5	33354	1.650	20.2	39311
			85/71	79.2	34935	25042	1.882	18.6	35683	1.669	21.4	41752
	6.1	4.6	75/63	72.1	30934	23608	1.754	17.6	31683	1.552	20.4	37246
			80/67	72.8	33218	24472	1.762	18.9	33966	1.560	21.8	39559
			85/71	73.6	35633	25290	1.774	20.1	36382	1.572	23.1	42094
	8.1	8.2	75/63	69.1	31251	23743	1.698	18.4	31999	1.521	21.0	37326
			80/67	69.7	33572	24609	1.703	19.7	34320	1.526	22.5	39721
			85/71	70.3	36038	25434	1.710	21.1	36787	1.533	24.0	42307
70	4.3	2.3	75/63	86.8	29252	22897	2.048	14.3	30000	1.835	16.3	36502
			80/67	87.9	31366	23754	2.066	15.2	32114	1.853	17.3	38749
			85/71	89.0	33586	24564	2.087	16.1	34335	1.874	18.3	41104
	6.1	4.6	75/63	81.9	29794	23126	1.953	15.3	30542	1.751	17.4	36739
			80/67	82.7	31988	23994	1.964	16.3	32736	1.762	18.6	39045
			85/71	83.5	34323	24824	1.977	17.4	35072	1.775	19.8	41432
	8.1	8.2	75/63	79.0	30106	23258	1.898	15.9	30855	1.721	17.9	36876
			80/67	79.6	32349	24134	1.905	17.0	33098	1.728	19.2	39217
			85/71	80.2	34732	24969	1.914	18.1	35480	1.737	20.4	41634
80	4.3	2.3	75/63	96.6	27996	22369	2.265	12.4	28745	2.052	14.0	35981
			80/67	97.5	30064	23252	2.280	13.2	30813	2.067	14.9	38159
			85/71	98.7	32184	24070	2.307	14.0	32932	2.094	15.7	40409
	6.1	4.6	75/63	91.8	28560	22606	2.165	13.2	29308	1.963	14.9	36217
			80/67	92.5	30690	23493	2.177	14.1	31439	1.975	15.9	38432
			85/71	93.3	32910	24326	2.192	15.0	33659	1.990	16.9	40755
	8.1	8.2	75/63	88.9	28887	22744	2.108	13.7	29636	1.931	15.4	36350
			80/67	89.5	31059	23635	2.116	14.7	31807	1.939	16.4	38599
			85/71	90.0	33329	24473	2.126	15.7	34078	1.949	17.5	40958
85	4.3	2.3	75/63	101.5	27352	22100	2.383	11.5	28101	2.170	12.9	35718
			80/67	102.5	29370	22986	2.403	12.2	30119	2.190	13.8	37855
			85/71	103.5	31451	23814	2.426	13.0	32199	2.213	14.5	40071
	6.1	4.6	75/63	96.7	27923	22339	2.279	12.3	28671	2.077	13.8	35951
			80/67	97.4	30016	23235	2.292	13.1	30765	2.090	14.7	38131
			85/71	98.2	32176	24068	2.307	13.9	32925	2.105	15.6	40436
	8.1	8.2	75/63	93.9	28255	22478	2.219	12.7	29004	2.042	14.2	36102
			80/67	94.4	30397	23381	2.227	13.6	31146	2.050	15.2	38287
			85/71	95.0	32610	24220	2.239	14.6	33359	2.062	16.2	40611
90	4.3	2.3	75/63	106.4	26692	21823	2.509	10.6	27441	2.296	12.0	35520
			80/67	107.4	28643	22706	2.529	11.3	29392	2.316	12.7	37565
			85/71	108.4	30697	23550	2.552	12.0	31446	2.339	13.4	39737
	6.1	4.6	75/63	101.6	27269	22064	2.398	11.4	28018	2.196	12.8	35686
			80/67	102.3	29319	22966	2.412	12.2	30068	2.210	13.6	37833
			85/71	103.1	31440	23810	2.428	12.9	32189	2.226	14.5	40067
	8.1	8.2	75/63	98.8	27605	22206	2.336	11.8	28354	2.159	13.1	35823
			80/67	99.3	29693	23109	2.346	12.7	30441	2.169	14.0	37996
			85/71	99.9	31871	23961	2.357	13.5	32620	2.180	15.0	40264
100	4.3	2.3	75/63	116.2	25301	21241	2.786	9.1	26050	2.573	10.1	35032
			80/67	117.2	27155	22137	2.807	9.7	27904	2.594	10.8	37006
			85/71	118.1	29112	22995	2.831	10.3	29860	2.618	11.4	39079
	6.1	4.6	75/63	111.5	25902	21493	2.663	9.7	26651	2.461	10.8	35225
			80/67	112.2	27839	22399	2.677	10.4	28587	2.475	11.5	37254
			85/71	112.9	29883	23265	2.693	11.1	30631	2.491	12.3	39391
	8.1	8.2	75/63	108.7	26247	21637	2.595	10.1	26996	2.418	11.2	35343
			80/67	109.2	28231	22549	2.604	10.8	28979	2.427	11.9	37403
			85/71	109.7	30327	23421	2.616	11.6	31075	2.439	12.7	39576
110	4.3	2.3	75/63	126.1	23786	20603	3.109	7.7	24535	2.896	8.5	34612
			80/67	126.9	25554	21522	3.130	8.2	26303	2.917	9.0	36482
			85/71	127.9	27404	22399	3.154	8.7	28153	2.941	9.6	38444
	6.1	4.6	75/63	121.4	24422	20872	2.970	8.2	25171	2.768	9.1	34780
			80/67	122.0	26273	21798	2.983	8.8	27021	2.781	9.7	36707
			85/71	122.7	28214	22683	2.998	9.4	28962	2.796	10.4	38735
	8.1	8.2	75/63	118.6	24802	21031	2.892	8.6	25550	2.715	9.4	34882
			80/67	119.1	26681	21955	2.901	9.2	27430	2.724	10.1	36842
			85/71	119.6	28674	22843	2.912	9.8	29423	2.735	10.8	38908

# Heating Capacity Data – Vertical Unit Size 030

EWT	GPM	WPD	System Heating					ISO System Heating			
			EA	LWT	TOT	kW	COP	TOT	kW	COP	THA
20	4.3	2.3	60	13.4	21216	1.989	3.12	20468	1.776	3.37	15002
			70	13.8	21227	2.204	2.82	20479	1.991	3.01	14232
			80	14.1	21252	2.452	2.54	20503	2.239	2.68	13389
	6.1	4.6	60	15.2	21793	1.998	3.19	21044	1.796	3.43	15559
			70	15.5	21756	2.214	2.88	21008	2.012	3.06	14738
			80	15.7	21736	2.462	2.59	20987	2.260	2.72	13846
	8.1	8.2	60	16.3	22166	2.004	3.24	21417	1.827	3.43	15918
			70	16.5	22091	2.22	2.91	21343	2.043	3.06	15076
			80	16.7	22044	2.468	2.62	21296	2.291	2.72	14137
30	4.3	2.3	60	22.2	24059	2.033	3.47	23311	1.820	3.75	17754
			70	22.6	23976	2.252	3.12	23227	2.039	3.34	16876
			80	23.0	23939	2.505	2.80	23190	2.292	2.96	15924
	6.1	4.6	60	24.3	24785	2.043	3.55	24037	1.841	3.82	18463
			70	24.6	24648	2.264	3.19	23900	2.062	3.39	17523
			80	24.9	24555	2.517	2.86	23807	2.315	3.01	16510
	8.1	8.2	60	25.6	25257	2.05	3.61	24508	1.873	3.83	18921
			70	25.8	25081	2.271	3.23	24333	2.094	3.40	17939
			80	26.1	24947	2.525	2.89	24199	2.348	3.02	16886
40	4.3	2.3	60	30.8	27202	2.079	3.83	26454	1.866	4.15	20796
			70	31.3	27020	2.304	3.43	26271	2.091	3.68	19808
			80	31.7	26884	2.562	3.07	26135	2.349	3.26	18749
	6.1	4.6	60	33.3	28112	2.093	3.93	27363	1.891	4.24	21684
			70	33.6	27864	2.319	3.52	27115	2.117	3.75	20617
			80	33.9	27662	2.578	3.14	26913	2.376	3.32	19476
	8.1	8.2	60	34.8	28699	2.102	4.00	27950	1.925	4.25	22260
			70	35.0	28408	2.328	3.57	27659	2.151	3.77	21142
			80	35.3	28161	2.587	3.19	27412	2.410	3.33	19951
50	4.3	2.3	60	39.3	30638	2.132	4.21	29889	1.919	4.56	24115
			70	39.8	30353	2.363	3.76	29604	2.150	4.03	23003
			80	40.4	30117	2.627	3.36	29368	2.414	3.56	21814
	6.1	4.6	60	42.1	31777	2.151	4.33	31028	1.949	4.66	25222
			70	42.5	31413	2.383	3.86	30665	2.181	4.12	24026
			80	42.9	31093	2.648	3.44	30344	2.446	3.63	22751
	8.1	8.2	60	43.9	32506	2.163	4.40	31757	1.986	4.68	25949
			70	44.2	32089	2.396	3.92	31341	2.219	4.14	24666
			80	44.5	31714	2.661	3.49	30966	2.484	3.65	23325
60	4.3	2.3	60	47.7	34384	2.196	4.58	33635	1.983	4.97	27704
			70	48.3	33991	2.433	4.09	33242	2.220	4.38	26469
			80	48.9	33643	2.704	3.64	32894	2.491	3.87	25132
	6.1	4.6	60	50.9	35774	2.221	4.72	35026	2.019	5.08	29045
			70	51.3	35268	2.459	4.20	34519	2.257	4.48	27702
			80	51.8	34844	2.732	3.73	34096	2.530	3.95	26273
	8.1	8.2	60	52.9	36491	2.233	4.78	35742	2.056	5.09	29964
			70	53.3	36126	2.477	4.27	35377	2.300	4.50	28511
			80	53.6	35610	2.751	3.79	34861	2.574	3.97	27009
70	4.3	2.3	60	56.0	38214	2.266	4.94	37466	2.053	5.34	31556
			70	56.6	37907	2.516	4.41	37158	2.303	4.72	30167
			80	57.3	37474	2.797	3.92	36725	2.584	4.16	28699
	6.1	4.6	60	59.6	40130	2.306	5.10	39382	2.104	5.48	33173
			70	60.1	39496	2.553	4.53	38748	2.351	4.83	31657
			80	60.6	38891	2.833	4.02	38142	2.631	4.24	30049
	8.1	8.2	60	61.9	41004	2.324	5.17	40256	2.147	5.49	34247
			70	62.3	40508	2.577	4.60	39759	2.400	4.85	32614
			80	62.7	39833	2.858	4.08	39085	2.681	4.27	30925
80	4.3	2.3	60	64.1	42510	2.357	5.28	41761	2.144	5.70	35644
			70	64.8	42095	2.616	4.71	41347	2.403	5.04	34083
			80	65.6	41487	2.904	4.18	40738	2.691	4.43	32449
	6.1	4.6	60	68.2	44742	2.409	5.44	43994	2.207	5.84	37508
			70	68.8	44016	2.665	4.84	43267	2.463	5.14	35826
			80	69.3	43241	2.954	4.29	42492	2.752	4.52	34049
	8.1	8.2	60	70.8	46080	2.441	5.53	45331	2.264	5.86	38750
			70	71.3	45193	2.697	4.91	44444	2.520	5.17	36971
			80	71.7	44327	2.986	4.35	43578	2.809	4.54	35070
85	4.3	2.3	60	68.2	44936	2.414	5.45	44188	2.201	5.88	37739
			70	68.9	44276	2.672	4.85	43527	2.459	5.18	36107
			80	69.7	43622	2.965	4.31	42874	2.752	4.56	34391
	6.1	4.6	60	72.5	47146	2.468	5.59	46398	2.266	5.99	39782
			70	73.1	46342	2.729	4.97	45593	2.527	5.28	38033
			80	73.7	45502	3.023	4.41	44753	2.821	4.64	36133
	8.1	8.2	60	75.3	48610	2.503	5.69	47862	2.326	6.03	41168
			70	75.7	47659	2.766	5.05	46910	2.589	5.31	39231
			80	76.2	46699	3.061	4.47	45951	2.884	4.67	37214
90	4.3	2.3	60	72.2	47305	2.472	5.60	46556	2.259	6.03	39891
			70	73.0	46554	2.735	4.98	45806	2.522	5.32	38171
			80	73.8	45789	3.032	4.42	45040	2.819	4.68	36365
	6.1	4.6	60	76.8	49637	2.53	5.74	48889	2.328	6.15	42115
			70	77.4	48745	2.798	5.10	47996	2.596	5.41	40231
			80	78.0	47839	3.098	4.52	47090	2.896	4.76	38212
	8.1	8.2	60	79.7	51270	2.575	5.83	50521	2.398	6.17	43546
			70	80.2	50179	2.842	5.17	49431	2.665	5.43	41535
			80	80.7	49126	3.141	4.58	48377	2.964	4.78	39395

# Cooling Capacity Data – Vertical Unit Size 036

EWT	GPM	WPD	System Cooling						ISO System Cooling			
			EA	LWT	TOT	SEN	kW	EER	TOT	kW	EER	THR
30	5.2	3.4	75/63	47.3	38643	29424	1.589	24.3	39541	1.337	29.6	44297
			80/67	48.5	41452	30411	1.620	25.6	42350	1.368	31.0	47295
			85/71	49.7	44401	31330	1.654	26.8	45299	1.402	32.3	50380
	7.3	6.6	75/63	42.4	39189	29668	1.487	26.4	40087	1.254	32.0	44516
			80/67	43.2	42099	30677	1.515	27.8	42997	1.282	33.5	47603
			85/71	44.1	45175	31621	1.545	29.2	46073	1.312	35.1	50798
	9.8	11.9	75/63	39.2	39527	29820	1.419	27.9	40425	1.229	32.9	44644
			80/67	39.9	42529	30854	1.445	29.4	43427	1.255	34.6	47774
			85/71	40.6	45636	31794	1.472	31.0	46534	1.282	36.3	51045
40	5.2	3.4	75/63	57.2	37533	28930	1.778	21.1	38431	1.526	25.2	43782
			80/67	58.3	40254	29921	1.805	22.3	41153	1.553	26.5	46662
			85/71	59.5	43080	30836	1.834	23.5	43978	1.582	27.8	49647
	7.3	6.6	75/63	52.3	38106	29185	1.683	22.6	39004	1.450	26.9	44080
			80/67	53.1	40915	30191	1.705	24.0	41813	1.472	28.4	47008
			85/71	54.0	43852	31124	1.730	25.3	44750	1.497	29.9	50064
	9.8	11.9	75/63	49.2	38460	29343	1.621	23.7	39358	1.431	27.5	44209
			80/67	49.8	41327	30360	1.641	25.2	42226	1.451	29.1	47231
			85/71	50.5	44339	31307	1.663	26.7	45237	1.473	30.7	50339
50	5.2	3.4	75/63	67.0	36349	28406	1.970	18.5	37247	1.718	21.7	43214
			80/67	68.1	38930	29382	1.993	19.5	39829	1.741	22.9	45947
			85/71	69.2	41670	30311	2.019	20.6	42569	1.767	24.1	48820
	7.3	6.6	75/63	62.2	36918	28657	1.877	19.7	37817	1.644	23.0	43493
			80/67	63.0	39629	29666	1.896	20.9	40527	1.663	24.4	46346
			85/71	63.8	42452	30602	1.917	22.1	43351	1.684	25.7	49294
	9.8	11.9	75/63	59.1	37284	28820	1.818	20.5	38182	1.628	23.5	43668
			80/67	59.7	40043	29835	1.835	21.8	40941	1.645	24.9	46599
			85/71	60.3	42943	30785	1.853	23.2	43842	1.663	26.4	49587
60	5.2	3.4	75/63	76.8	35036	27827	2.172	16.1	35934	1.920	18.7	42552
			80/67	77.8	37533	28818	2.193	17.1	38431	1.941	19.8	45213
			85/71	78.9	40178	29760	2.217	18.1	41076	1.965	20.9	47967
	7.3	6.6	75/63	72.0	35657	28100	2.077	17.2	36555	1.844	19.8	42868
			80/67	72.8	38230	29099	2.093	18.3	39128	1.860	21.0	45562
			85/71	73.6	40969	30052	2.112	19.4	41867	1.879	22.3	48428
	9.8	11.9	75/63	69.0	36039	28269	2.019	17.9	36938	1.829	20.2	43057
			80/67	69.6	38664	29274	2.031	19.0	39562	1.841	21.5	45802
			85/71	70.2	41467	30236	2.047	20.3	42365	1.857	22.8	48742
70	5.2	3.4	75/63	86.5	33644	27216	2.393	14.1	34543	2.141	16.1	41914
			80/67	87.5	36061	28226	2.413	14.9	36959	2.161	17.1	44434
			85/71	88.6	38612	29184	2.436	15.9	39510	2.184	18.1	47103
	7.3	6.6	75/63	81.9	34261	27487	2.293	14.9	35159	2.060	17.1	42214
			80/67	82.6	36762	28507	2.307	15.9	37660	2.074	18.2	44774
			85/71	83.4	39407	29476	2.324	17.0	40305	2.091	19.3	47563
	9.8	11.9	75/63	78.9	34656	27660	2.231	15.5	35554	2.041	17.4	42382
			80/67	79.4	37204	28684	2.242	16.6	38102	2.052	18.6	45005
			85/71	80.0	39905	29660	2.255	17.7	40804	2.065	19.8	47808
80	5.2	3.4	75/63	96.3	32176	26575	2.642	12.2	33074	2.390	13.8	41194
			80/67	97.2	34495	27598	2.662	13.0	35393	2.410	14.7	43663
			85/71	98.2	36938	28573	2.683	13.8	37836	2.431	15.6	46234
	7.3	6.6	75/63	91.7	32828	26860	2.533	13.0	33726	2.300	14.7	41502
			80/67	92.4	35216	27887	2.546	13.8	36114	2.313	15.6	44035
			85/71	93.1	37762	28874	2.561	14.7	38660	2.328	16.6	46627
	9.8	11.9	75/63	88.7	33218	27030	2.466	13.5	34116	2.276	15.0	41685
			80/67	89.3	35664	28066	2.475	14.4	36562	2.285	16.0	44263
			85/71	89.8	38267	29058	2.486	15.4	39165	2.296	17.1	46897
85	5.2	3.4	75/63	101.2	31412	26241	2.780	11.3	32310	2.528	12.8	40896
			80/67	102.1	33699	27280	2.800	12.0	34597	2.548	13.6	43291
			85/71	103.1	36068	28255	2.822	12.8	36966	2.570	14.4	45796
	7.3	6.6	75/63	96.6	32051	26520	2.664	12.0	32949	2.431	13.6	41165
			80/67	97.3	34405	27561	2.677	12.9	35303	2.444	14.4	43604
			85/71	98.0	36849	28539	2.692	13.7	37747	2.459	15.3	46205
	9.8	11.9	75/63	93.7	32462	26700	2.594	12.5	33361	2.404	13.9	41346
			80/67	94.2	34866	27748	2.602	13.4	35765	2.412	14.8	43835
			85/71	94.7	37419	28748	2.613	14.3	38317	2.423	15.8	46449
90	5.2	3.4	75/63	106.1	30630	25900	2.928	10.5	31528	2.676	11.8	40580
			80/67	107.0	32869	26948	2.948	11.1	33767	2.696	12.5	42937
			85/71	108.0	35177	27930	2.970	11.8	36075	2.718	13.3	45387
	7.3	6.6	75/63	101.5	31275	26182	2.805	11.1	32173	2.572	12.5	40839
			80/67	102.2	33592	27237	2.818	11.9	34491	2.585	13.3	43247
			85/71	102.9	36001	28231	2.833	12.7	36899	2.600	14.2	45764
	9.8	11.9	75/63	98.6	31676	26357	2.731	11.6	32575	2.541	12.8	41006
			80/67	99.1	34044	27417	2.739	12.4	34942	2.549	13.7	43449
			85/71	99.7	36513	28417	2.750	13.3	37411	2.560	14.6	46009
100	5.2	3.4	75/63	115.9	29003	25191	3.261	8.9	29901	3.009	9.9	40082
			80/67	116.8	31114	26247	3.281	9.5	32012	3.029	10.6	42275
			85/71	117.7	33333	27259	3.305	10.1	34231	3.053	11.2	44612
	7.3	6.6	75/63	111.4	29662	25479	3.121	9.5	30561	2.888	10.6	40223
			80/67	112.0	31862	26546	3.134	10.2	32760	2.901	11.3	42547
			85/71	112.7	34176	27566	3.148	10.9	35075	2.915	12.0	44952
	9.8	11.9	75/63	108.5	30070	25657	3.038	9.9	30968	2.848	10.9	40371
			80/67	109.0	32346	26740	3.046	10.6	33244	2.856	11.6	42725
			85/71	109.5	34696	27754	3.055	11.4	35594	2.865	12.4	45172
110	5.2	3.4	75/63	125.7	27273	24431	3.650	7.5	28172	3.398	8.3	39567
			80/67	126.6	29262	25505	3.672	8.0	30160	3.420	8.8	41684
			85/71	127.4	31363	26540	3.696	8.5	32261	3.444	9.4	43901
	7.3	6.6	75/63	121.2	27958	24733	3.491	8.0	28857	3.258	8.9	39743
			80/67	121.9	30040	25818	3.504	8.6	30938	3.271	9.5	41918
			85/71	122.5	32238	26860	3.518	9.2	33136	3.285	10.1	44203
	9.8	11.9	75/63	118.4	28378	24917	3.397	8.4	29276	3.207	9.1	39860
			80/67	118.9	30515	26008	3.404	9.0	31413	3.214	9.8	42071
			85/71	119.4	32774	27055	3.413	9.6	33672	3.223	10.4	44398

# Heating Capacity Data – Vertical Unit Size 036

EWT	GPM	WPD	System Heating					ISO System Heating			
			EA	LWT	TOT	kW	COP	TOT	kW	COP	THA
20	5.2	3.4	60	13.5	25342	2.405	3.09	24444	2.153	3.32	17835
			70	13.9	25408	2.678	2.78	24509	2.426	2.96	16917
			80	14.2	25460	2.985	2.50	24561	2.733	2.63	15892
	7.3	6.6	60	15.2	26011	2.416	3.15	25113	2.183	3.37	18483
			70	15.5	26019	2.689	2.83	25121	2.456	2.99	17504
			80	15.8	26016	2.996	2.54	25118	2.763	2.66	16418
	9.8	11.9	60	16.4	26476	2.423	3.20	25578	2.233	3.35	18932
			70	16.6	26440	2.696	2.87	25541	2.506	2.98	17908
			80	16.8	26413	3.004	2.57	25515	2.814	2.65	16788
30	5.2	3.4	60	22.3	28750	2.458	3.42	27852	2.206	3.70	21138
			70	22.7	28682	2.734	3.07	27784	2.482	3.28	20081
			80	23.1	28648	3.049	2.75	27750	2.797	2.91	18903
	7.3	6.6	60	24.3	29590	2.471	3.51	28692	2.238	3.75	21949
			70	24.6	29453	2.748	3.14	28555	2.515	3.32	20811
			80	24.9	29353	3.062	2.81	28455	2.829	2.94	19573
	9.8	11.9	60	25.6	30171	2.48	3.56	29273	2.290	3.74	22515
			70	25.9	29986	2.757	3.18	29088	2.567	3.32	21323
			80	26.1	29836	3.072	2.84	28938	2.882	2.94	20034
40	5.2	3.4	60	31.0	32470	2.515	3.78	31571	2.263	4.08	24743
			70	31.4	32288	2.796	3.38	31390	2.544	3.61	23537
			80	31.9	32136	3.118	3.02	31238	2.866	3.19	22235
	7.3	6.6	60	33.3	33540	2.532	3.88	32641	2.299	4.16	25775
			70	33.6	33251	2.813	3.46	32352	2.580	3.67	24461
			80	34.0	33021	3.136	3.08	32123	2.903	3.24	23067
	9.8	11.9	60	34.9	34261	2.543	3.94	33363	2.353	4.15	26469
			70	35.1	33917	2.825	3.52	33019	2.635	3.67	25103
			80	35.4	33629	3.148	3.13	32731	2.958	3.24	23646
50	5.2	3.4	60	39.5	36545	2.58	4.15	35647	2.328	4.48	28669
			70	40.0	36224	2.867	3.70	35326	2.615	3.96	27306
			80	40.5	35933	3.196	3.29	35035	2.944	3.48	25849
	7.3	6.6	60	42.2	37864	2.602	4.26	36966	2.369	4.57	29926
			70	42.6	37427	2.89	3.79	36529	2.657	4.03	28456
			80	43.0	37055	3.221	3.37	36157	2.988	3.54	26904
	9.8	11.9	60	44.0	38756	2.617	4.34	37858	2.427	4.57	30804
			70	44.3	38248	2.906	3.85	37349	2.716	4.03	29260
			80	44.6	37809	3.237	3.42	36910	3.047	3.55	27604
60	5.2	3.4	60	47.9	40952	2.656	4.51	40054	2.404	4.88	32890
			70	48.5	40533	2.951	4.02	39635	2.699	4.30	31360
			80	49.1	40097	3.289	3.57	39199	3.037	3.78	29753
	7.3	6.6	60	51.0	42564	2.686	4.64	41666	2.453	4.97	34418
			70	51.4	41964	2.98	4.12	41065	2.747	4.38	32766
			80	51.9	41427	3.32	3.65	40528	3.087	3.84	31028
	9.8	11.9	60	53.1	43656	2.706	4.72	42758	2.516	4.98	35464
			70	53.4	42979	3.001	4.19	42081	2.811	4.38	33735
			80	53.8	42381	3.343	3.71	41483	3.153	3.85	31911
70	5.2	3.4	60	56.2	45685	2.745	4.87	44787	2.493	5.26	37388
			70	56.9	45063	3.046	4.33	44164	2.794	4.63	35712
			80	57.5	44566	3.397	3.84	43667	3.145	4.07	33946
	7.3	6.6	60	59.7	47635	2.781	5.02	46737	2.548	5.37	39239
			70	60.2	46834	3.086	4.44	45936	2.853	4.71	37405
			80	60.7	46191	3.438	3.93	45293	3.205	4.14	35453
	9.8	11.9	60	62.1	48944	2.808	5.10	48046	2.618	5.37	40496
			70	62.5	48072	3.115	4.52	47174	2.925	4.72	38539
			80	62.9	47322	3.468	4.00	46424	3.278	4.15	36499
80	5.2	3.4	60	64.4	50768	2.847	5.22	49870	2.595	5.63	42205
			70	65.1	49978	3.161	4.63	49080	2.909	4.94	40298
			80	65.9	49322	3.522	4.10	48423	3.270	4.34	38335
	7.3	6.6	60	68.3	53007	2.897	5.36	52109	2.664	5.73	44349
			70	68.9	52110	3.214	4.75	51211	2.981	5.03	42309
			80	69.5	51282	3.578	4.20	50383	3.345	4.41	40106
	9.8	11.9	60	71.0	54578	2.933	5.45	53680	2.743	5.73	45840
			70	71.5	53559	3.246	4.83	52661	3.056	5.05	43666
			80	71.9	52585	3.616	4.26	51687	3.426	4.42	41352
85	5.2	3.4	60	68.5	53408	2.906	5.38	52510	2.654	5.79	44683
			70	69.2	52574	3.226	4.77	51676	2.974	5.09	42700
			80	70.0	51796	3.593	4.22	50898	3.341	4.46	40609
	7.3	6.6	60	72.6	55843	2.963	5.52	54944	2.730	5.89	46993
			70	73.2	54843	3.28	4.90	53945	3.047	5.18	44851
			80	73.8	53916	3.656	4.32	53018	3.423	4.53	42535
	9.8	11.9	60	75.5	57569	3.005	5.61	56671	2.815	5.89	48568
			70	75.9	56433	3.324	4.97	55535	3.134	5.19	46333
			80	76.4	55343	3.7	4.38	54444	3.510	4.54	43859
90	5.2	3.4	60	72.6	56120	2.97	5.53	55222	2.718	5.95	47214
			70	73.3	55214	3.291	4.91	54316	3.039	5.23	45162
			80	74.1	54327	3.668	4.34	53429	3.416	4.58	42923
	7.3	6.6	60	76.9	58729	3.034	5.67	57830	2.801	6.04	49690
			70	77.5	57627	3.357	5.03	56729	3.124	5.32	47437
			80	78.2	56604	3.74	4.43	55706	3.507	4.65	45006
	9.8	11.9	60	79.9	60586	3.082	5.76	59687	2.892	6.04	51446
			70	80.4	59401	3.409	5.10	58503	3.219	5.32	48991
			80	80.9	58152	3.79	4.49	57254	3.600	4.66	46444

# Cooling Capacity Data – Vertical Unit Size 042

EWT	GPM	WPD	System Cooling						ISO System Cooling			
			EA	LWT	TOT	SEN	kW	EER	TOT	kW	EER	THR
30	6.0	3.9	75/63	48.1	44788	35370	1.709	26.2	46005	1.368	33.6	50702
			80/67	49.3	48073	36525	1.736	27.7	49290	1.395	35.3	54137
			85/71	50.6	51466	37573	1.768	29.1	52682	1.427	36.9	57717
	8.5	7.8	75/63	42.8	45274	35600	1.580	28.7	46491	1.265	36.7	50772
			80/67	43.7	48648	36775	1.603	30.3	49864	1.288	38.7	54300
			85/71	44.6	52149	37845	1.631	32.0	53366	1.316	40.5	57947
	11.4	14.1	75/63	39.5	45531	35721	1.502	30.3	46748	1.247	37.5	50789
			80/67	40.2	48961	36912	1.522	32.2	50178	1.267	39.6	54359
			85/71	40.9	52521	37994	1.548	33.9	53737	1.293	41.6	58051
40	6.0	3.9	75/63	58.0	43731	34871	1.946	22.5	44947	1.605	28.0	50342
			80/67	59.2	46854	35998	1.969	23.8	48071	1.628	29.5	53615
			85/71	60.4	50149	37051	1.996	25.1	51365	1.655	31.0	57069
	8.5	7.8	75/63	52.8	44316	35146	1.826	24.3	45532	1.511	30.1	50550
			80/67	53.6	47555	36301	1.844	25.8	48771	1.529	31.9	53926
			85/71	54.5	50938	37364	1.865	27.3	52154	1.550	33.6	57444
	11.4	14.1	75/63	49.5	44608	35284	1.753	25.4	45824	1.498	30.6	50661
			80/67	50.2	47936	36465	1.766	27.1	49152	1.511	32.5	54093
			85/71	50.8	51378	37538	1.785	28.8	52594	1.530	34.4	57657
50	6.0	3.9	75/63	67.9	42424	34258	2.184	19.4	43640	1.843	23.7	49824
			80/67	69.0	45447	35391	2.207	20.6	46663	1.866	25.0	52935
			85/71	70.2	48630	36453	2.231	21.8	49846	1.890	26.4	56264
	8.5	7.8	75/63	62.7	43089	34570	2.066	20.9	44305	1.751	25.3	50067
			80/67	63.5	46201	35715	2.083	22.2	47418	1.768	26.8	53317
			85/71	64.4	49501	36795	2.099	23.6	50718	1.784	28.4	56764
	11.4	14.1	75/63	59.5	43471	34749	1.995	21.8	44688	1.740	25.7	50243
			80/67	60.1	46643	35906	2.007	23.2	47860	1.752	27.3	53505
			85/71	60.7	50002	36993	2.020	24.8	51218	1.765	29.0	56998
60	6.0	3.9	75/63	77.6	40981	33587	2.432	16.9	42197	2.091	20.2	49120
			80/67	78.7	43888	34725	2.455	17.9	45104	2.114	21.3	52132
			85/71	79.9	46942	35794	2.480	18.9	48159	2.139	22.5	55318
	8.5	7.8	75/63	72.5	41693	33917	2.312	18.0	42909	1.997	21.5	49478
			80/67	73.3	44698	35071	2.328	19.2	45915	2.013	22.8	52546
			85/71	74.1	47872	36156	2.343	20.4	49089	2.028	24.2	55816
	11.4	14.1	75/63	69.4	42108	34111	2.240	18.8	43324	1.985	21.8	49605
			80/67	70.0	45174	35274	2.252	20.1	46391	1.997	23.2	52792
			85/71	70.6	48420	36371	2.263	21.4	49637	2.008	24.7	56189
70	6.0	3.9	75/63	87.4	39421	32866	2.700	14.6	40637	2.359	17.2	48346
			80/67	88.5	42197	34007	2.724	15.5	43414	2.383	18.2	51286
			85/71	89.6	45128	35090	2.750	16.4	46345	2.409	19.2	54348
	8.5	7.8	75/63	82.4	40162	33208	2.573	15.6	41378	2.258	18.3	48710
			80/67	83.1	43051	34369	2.588	16.6	44267	2.273	19.5	51738
			85/71	83.9	46101	35467	2.605	17.7	47317	2.290	20.7	54913
	11.4	14.1	75/63	79.3	40594	33408	2.498	16.3	41810	2.243	18.6	48925
			80/67	79.8	43551	34581	2.509	17.4	44767	2.254	19.9	51935
			85/71	80.4	46671	35688	2.521	18.5	47887	2.266	21.1	55184
80	6.0	3.9	75/63	97.1	37711	32080	2.996	12.6	38927	2.655	14.7	47549
			80/67	98.2	40399	33249	3.021	13.4	41615	2.680	15.5	50401
			85/71	99.2	43212	34351	3.048	14.2	44428	2.707	16.4	53348
	8.5	7.8	75/63	92.2	38489	32436	2.858	13.5	39705	2.543	15.6	47911
			80/67	92.9	41279	33619	2.874	14.4	42495	2.559	16.6	50850
			85/71	93.7	44207	34735	2.890	15.3	45424	2.575	17.6	53833
	11.4	14.1	75/63	89.1	38945	32646	2.779	14.0	40161	2.524	15.9	48128
			80/67	89.7	41795	33837	2.789	15.0	43012	2.534	17.0	51114
			85/71	90.3	44793	34960	2.800	16.0	46010	2.545	18.1	54148
85	6.0	3.9	75/63	102.0	36831	31677	3.157	11.7	38047	2.816	13.5	47154
			80/67	103.0	39462	32856	3.184	12.4	40678	2.843	14.3	49967
			85/71	103.9	42250	33983	3.203	13.2	43467	2.862	15.2	52853
	8.5	7.8	75/63	97.1	37618	32037	3.013	12.5	38834	2.698	14.4	47511
			80/67	97.8	40352	33229	3.028	13.3	41568	2.713	15.3	50353
			85/71	98.6	43220	34355	3.045	14.2	44437	2.730	16.3	53314
	11.4	14.1	75/63	94.1	38080	32248	2.930	13.0	39297	2.675	14.7	47726
			80/67	94.6	40874	33449	2.940	13.9	42091	2.685	15.7	50609
			85/71	95.2	43811	34582	2.952	14.8	45028	2.697	16.7	53623
90	6.0	3.9	75/63	106.9	35927	31264	3.332	10.8	37144	2.991	12.4	46833
			80/67	107.9	38500	32453	3.357	11.5	39716	3.016	13.2	49537
			85/71	108.9	41150	33562	3.384	12.2	42366	3.043	13.9	52301
	8.5	7.8	75/63	102.0	36723	31628	3.178	11.6	37939	2.863	13.2	47109
			80/67	102.7	39399	32829	3.194	12.3	40616	2.879	14.1	49902
			85/71	103.3	42200	33963	3.206	13.2	43417	2.891	15.0	52851
	11.4	14.1	75/63	99.0	37192	31843	3.091	12.0	38409	2.836	13.5	47334
			80/67	99.5	39937	33055	3.101	12.9	41154	2.846	14.5	50135
			85/71	100.1	42771	34182	3.113	13.7	43987	2.858	15.4	53086
100	6.0	3.9	75/63	116.7	34051	30412	3.714	9.2	35268	3.373	10.5	46137
			80/67	117.6	36502	31620	3.741	9.8	37719	3.400	11.1	48666
			85/71	118.6	39005	32746	3.771	10.3	40222	3.430	11.7	51338
	8.5	7.8	75/63	111.8	34866	30781	3.542	9.8	36082	3.227	11.2	46349
			80/67	112.5	37424	32004	3.559	10.5	38640	3.244	11.9	49034
			85/71	113.2	40054	33145	3.577	11.2	41270	3.262	12.7	51794
	11.4	14.1	75/63	108.9	35343	30999	3.445	10.3	36559	3.190	11.5	46532
			80/67	109.4	37962	32229	3.456	11.0	39178	3.201	12.2	49260
			85/71	109.9	40665	33377	3.468	11.7	41882	3.213	13.0	52072
110	6.0	3.9	75/63	126.5	32079	29515	4.156	7.7	33295	3.815	8.7	45479
			80/67	127.4	34357	30728	4.185	8.2	35574	3.844	9.3	47909
			85/71	128.3	36744	31889	4.216	8.7	37960	3.875	9.8	50438
	8.5	7.8	75/63	121.7	32920	29897	3.963	8.3	34136	3.648	9.4	45728
			80/67	122.3	35314	31126	3.980	8.9	36530	3.665	10.0	48235
			85/71	123.0	37824	32298	3.999	9.5	39041	3.684	10.6	50853
	11.4	14.1	75/63	118.7	33408	30119	3.854	8.7	34624	3.599	9.6	45883
			80/67	119.2	35867	31356	3.864	9.3	37084	3.609	10.3	48435
			85/71	119.7	38451	32535	3.877	9.9	39667	3.622	11.0	51105



# Heating Capacity Data – Vertical Unit Size 042

EWT	GPM	WPD	System Heating					ISO System Heating			
			EA	LWT	TOT	kW	COP	TOT	kW	COP	THA
20	6.0	3.9	60	13.4	28533	2.616	3.19	27317	2.275	3.52	20604
			70	13.7	28606	2.919	2.87	27389	2.578	3.11	19610
			80	14.0	28678	3.257	2.58	27462	2.916	2.76	18524
	8.5	7.8	60	15.1	29309	2.629	3.26	28093	2.314	3.55	21355
			70	15.4	29320	2.932	2.93	28104	2.617	3.14	20291
			80	15.7	29330	3.272	2.62	28114	2.957	2.78	19139
	11.4	14.1	60	16.3	29826	2.638	3.31	28610	2.383	3.52	21852
			70	16.5	29791	2.941	2.97	28574	2.686	3.12	20743
			80	16.7	29787	3.282	2.66	28570	3.027	2.76	19543
30	6.0	3.9	60	22.1	32579	2.684	3.55	31362	2.343	3.92	24512
			70	22.5	32506	2.993	3.18	31290	2.652	3.46	23359
			80	22.9	32479	3.34	2.85	31262	2.999	3.05	22097
	8.5	7.8	60	24.2	33562	2.7	3.64	32345	2.385	3.97	25459
			70	24.5	33413	3.01	3.25	32196	2.695	3.50	24214
			80	24.8	33316	3.358	2.91	32099	3.043	3.09	22886
	11.4	14.1	60	25.6	34211	2.711	3.70	32995	2.456	3.93	26096
			70	25.8	34012	3.021	3.30	32795	2.766	3.47	24774
			80	26.0	33862	3.37	2.94	32645	3.115	3.07	23406
40	6.0	3.9	60	30.7	37007	2.757	3.93	35791	2.416	4.34	28775
			70	31.1	36762	3.072	3.50	35546	2.731	3.81	27446
			80	31.6	36625	3.43	3.13	35409	3.089	3.36	26035
	8.5	7.8	60	33.1	37789	2.766	4.00	36573	2.451	4.37	30034
			70	33.5	37927	3.095	3.59	36710	2.780	3.87	28556
			80	33.8	37674	3.453	3.19	36457	3.138	3.40	27018
	11.4	14.1	60	34.7	39044	2.791	4.10	37827	2.536	4.37	30778
			70	35.0	38681	3.109	3.64	37465	2.854	3.84	29258
			80	35.3	38366	3.468	3.24	37149	3.213	3.39	27673
50	6.0	3.9	60	39.1	41578	2.833	4.30	40362	2.492	4.74	33399
			70	39.6	41431	3.162	3.84	40215	2.821	4.17	31896
			80	40.2	41135	3.53	3.41	39919	3.189	3.67	30292
	8.5	7.8	60	42.0	43341	2.865	4.43	42125	2.550	4.84	34881
			70	42.4	42851	3.19	3.93	41635	2.875	4.24	33233
			80	42.8	42431	3.559	3.49	41214	3.244	3.72	31521
	11.4	14.1	60	43.9	44354	2.883	4.50	43138	2.628	4.81	35860
			70	44.2	43779	3.209	3.99	42563	2.954	4.22	34134
			80	44.5	43283	3.578	3.54	42067	3.323	3.71	32344
60	6.0	3.9	60	47.5	46950	2.929	4.69	45734	2.588	5.18	38333
			70	48.1	46430	3.262	4.17	45214	2.921	4.53	36637
			80	48.6	45992	3.641	3.70	44776	3.300	3.97	34854
	8.5	7.8	60	50.8	48780	2.963	4.82	47564	2.648	5.26	40116
			70	51.2	48146	3.298	4.27	46930	2.983	4.61	38264
			80	51.6	47531	3.677	3.79	46314	3.362	4.03	36333
	11.4	14.1	60	52.9	50021	2.986	4.91	48804	2.731	5.23	41281
			70	53.3	49282	3.321	4.35	48065	3.066	4.59	39344
			80	53.6	48592	3.704	3.84	47376	3.449	4.02	37311
70	6.0	3.9	60	55.8	52419	3.028	5.07	51202	2.687	5.58	43565
			70	56.4	51745	3.374	4.49	50528	3.033	4.88	41664
			80	57.1	51104	3.765	3.97	49887	3.424	4.27	39672
	8.5	7.8	60	59.5	54646	3.072	5.21	53430	2.757	5.67	45688
			70	60.0	53838	3.421	4.61	52621	3.106	4.96	43598
			80	60.4	52982	3.812	4.07	51766	3.497	4.33	41446
	11.4	14.1	60	61.9	56122	3.101	5.30	54906	2.846	5.65	47092
			70	62.3	55141	3.449	4.68	53925	3.194	4.94	44881
			80	62.7	54226	3.844	4.13	53010	3.589	4.33	42589
80	6.0	3.9	60	64.0	58248	3.145	5.42	57031	2.804	5.96	49078
			70	64.6	57325	3.499	4.80	56108	3.158	5.20	46960
			80	65.4	56544	3.904	4.24	55327	3.563	4.55	44714
	8.5	7.8	60	68.1	60550	3.191	5.56	59334	2.876	6.04	51562
			70	68.6	59738	3.552	4.92	58522	3.237	5.29	49228
			80	69.2	58758	3.963	4.34	57542	3.648	4.62	46768
	11.4	14.1	60	70.8	62512	3.235	5.66	61295	2.980	6.02	53147
			70	71.3	61330	3.59	5.00	60114	3.335	5.28	50739
			80	71.7	60195	4.003	4.40	58979	3.748	4.61	48115
85	6.0	3.9	60	68.0	61170	3.206	5.59	59954	2.865	6.13	51933
			70	68.7	60277	3.565	4.95	59061	3.224	5.36	49694
			80	69.5	59333	3.979	4.37	58116	3.638	4.68	47298
	8.5	7.8	60	72.4	63731	3.26	5.72	62515	2.945	6.21	54563
			70	73.0	62831	3.627	5.07	61615	3.312	5.45	52107
			80	73.6	61701	4.044	4.47	60485	3.729	4.75	49511
	11.4	14.1	60	75.3	65574	3.301	5.82	64358	3.046	6.19	56333
			70	75.7	64555	3.67	5.15	63339	3.415	5.43	53685
			80	76.2	63237	4.088	4.53	62021	3.832	4.74	50966
90	6.0	3.9	60	72.1	64265	3.273	5.75	63049	2.932	6.30	54782
			70	72.8	63236	3.638	5.09	62020	3.297	5.51	52455
			80	73.6	62167	4.057	4.49	60951	3.716	4.80	49963
	8.5	7.8	60	76.7	67193	3.339	5.89	65977	3.024	6.39	57566
			70	77.3	65959	3.706	5.21	64742	3.391	5.59	55027
			80	77.9	64713	4.124	4.59	63497	3.809	4.88	52318
	11.4	14.1	60	79.7	69277	3.388	5.99	68060	3.133	6.36	59433
			70	80.2	67796	3.754	5.29	66580	3.499	5.57	56778
			80	80.7	66441	4.175	4.66	65224	3.920	4.87	53815

# Cooling Capacity Data – Vertical Unit Size 048

EWT	GPM	WPD	System Cooling						ISO System Cooling			
			EA	LWT	TOT	SEN	kW	EER	TOT	kW	EER	THR
30	6.9	5.2	75/63	48.3	50687	40508	2.141	23.7	51949	1.794	29.0	57906
			80/67	49.5	54306	41769	2.182	24.9	55568	1.835	30.3	61829
			85/71	50.8	58121	42943	2.220	26.2	59382	1.873	31.7	65765
	9.8	10.4	75/63	42.9	51280	40794	2.002	25.6	52542	1.697	31.0	58132
			80/67	43.8	55120	42131	2.036	27.1	56382	1.731	32.6	62201
			85/71	44.7	59079	43333	2.069	28.6	60341	1.764	34.2	66279
	13.0	18.3	75/63	39.7	51634	40966	1.918	26.9	52896	1.698	31.2	58235
			80/67	40.4	55560	42327	1.949	28.5	56822	1.729	32.9	62335
			85/71	41.1	59609	43549	1.980	30.1	60871	1.760	34.6	66546
40	6.9	5.2	75/63	58.1	49290	39836	2.400	20.5	50552	2.053	24.6	57312
			80/67	59.3	52777	41093	2.434	21.7	54038	2.087	25.9	61011
			85/71	60.5	56406	42250	2.469	22.8	57668	2.122	27.2	64782
	9.8	10.4	75/63	52.8	50023	40187	2.269	22.0	51285	1.964	26.1	57653
			80/67	53.7	53631	41470	2.296	23.4	54893	1.991	27.6	61402
			85/71	54.6	57408	42655	2.326	24.7	58670	2.021	29.0	65356
	13.0	18.3	75/63	49.7	50430	40383	2.192	23.0	51692	1.972	26.2	57888
			80/67	50.3	54102	41678	2.217	24.4	55363	1.997	27.7	61653
			85/71	51.0	57969	42882	2.243	25.8	59230	2.023	29.3	65673
50	6.9	5.2	75/63	67.9	47746	39098	2.660	17.9	49008	2.313	21.2	56576
			80/67	69.1	51129	40370	2.688	19.0	52391	2.341	22.4	60086
			85/71	70.2	54576	41516	2.720	20.1	55838	2.373	23.5	63699
	9.8	10.4	75/63	62.7	48527	39470	2.531	19.2	49789	2.226	22.4	57002
			80/67	63.5	52011	40757	2.553	20.4	53273	2.248	23.7	60546
			85/71	64.4	55604	41928	2.581	21.5	56866	2.276	25.0	64334
	13.0	18.3	75/63	59.6	48970	39683	2.456	19.9	50232	2.236	22.5	57185
			80/67	60.2	52511	40976	2.476	21.2	53773	2.256	23.8	60825
			85/71	60.9	56189	42163	2.500	22.5	57451	2.280	25.2	64699
60	6.9	5.2	75/63	77.7	46094	38313	2.932	15.7	47356	2.585	18.3	55695
			80/67	78.8	49295	39570	2.956	16.7	50556	2.609	19.4	59105
			85/71	79.9	52629	40740	2.988	17.6	53890	2.641	20.4	62580
	9.8	10.4	75/63	72.6	46918	38704	2.799	16.8	48180	2.494	19.3	56139
			80/67	73.3	50226	39976	2.818	17.8	51487	2.513	20.5	59594
			85/71	74.1	53692	41163	2.841	18.9	54954	2.536	21.7	63166
	13.0	18.3	75/63	69.5	47377	38921	2.724	17.4	48639	2.504	19.4	56369
			80/67	70.1	50749	40204	2.740	18.5	52011	2.520	20.6	59890
			85/71	70.7	54291	41402	2.759	19.7	55553	2.539	21.9	63528
70	6.9	5.2	75/63	87.5	44303	37468	3.228	13.7	45564	2.881	15.8	54820
			80/67	88.5	47337	38722	3.254	14.5	48598	2.907	16.7	58028
			85/71	89.5	50587	39933	3.279	15.4	51849	2.932	17.7	61369
	9.8	10.4	75/63	82.4	45159	37872	3.087	14.6	46421	2.782	16.7	55217
			80/67	83.1	48332	39153	3.104	15.6	49594	2.799	17.7	58590
			85/71	83.9	51675	40362	3.123	16.5	52937	2.818	18.8	62051
	13.0	18.3	75/63	79.4	45628	38093	3.008	15.2	46890	2.788	16.8	55488
			80/67	79.9	48876	39389	3.020	16.2	50138	2.800	17.9	58807
			85/71	80.5	52285	40604	3.037	17.2	53546	2.817	19.0	62421
80	6.9	5.2	75/63	97.2	42407	36580	3.563	11.9	43669	3.216	13.6	53962
			80/67	98.1	45378	37881	3.588	12.6	46639	3.241	14.4	57097
			85/71	99.2	48438	39089	3.617	13.4	49700	3.270	15.2	60274
	9.8	10.4	75/63	92.2	43288	36992	3.406	12.7	44550	3.101	14.4	54343
			80/67	92.9	46299	38276	3.424	13.5	47561	3.119	15.3	57559
			85/71	93.7	49556	39527	3.438	14.4	50818	3.133	16.2	60887
	13.0	18.3	75/63	89.2	43799	37232	3.320	13.2	45061	3.100	14.5	54575
			80/67	89.8	46840	38509	3.333	14.1	48102	3.113	15.5	57797
			85/71	89.8	47176	38647	3.333	14.2	48438	3.113	15.6	58160
85	6.9	5.2	75/63	102.1	41430	36124	3.749	11.1	42692	3.402	12.5	53525
			80/67	103.1	44297	37418	3.777	11.7	45558	3.430	13.3	56563
			85/71	104.1	47316	38650	3.803	12.4	48578	3.456	14.1	59724
	9.8	10.4	75/63	97.1	42338	36548	3.581	11.8	43599	3.276	13.3	53898
			80/67	97.8	45283	37839	3.598	12.6	46544	3.293	14.1	57034
			85/71	98.5	48443	39091	3.615	13.4	49705	3.310	15.0	60253
	13.0	18.3	75/63	94.2	42821	36773	3.491	12.3	44083	3.271	13.5	54122
			80/67	94.7	45870	38091	3.503	13.1	47131	3.283	14.4	57207
			85/71	95.3	49071	39337	3.514	14.0	50333	3.294	15.3	60578
90	6.9	5.2	75/63	107.0	40426	35657	3.950	10.2	41687	3.603	11.6	53118
			80/67	107.9	43265	36977	3.979	10.9	44527	3.632	12.3	56115
			85/71	108.9	46146	38194	4.006	11.5	47408	3.659	13.0	59149
	9.8	10.4	75/63	102.0	41314	36071	3.771	11.0	42576	3.466	12.3	53474
			80/67	102.7	44235	37392	3.789	11.7	45497	3.484	13.1	56508
			85/71	103.4	47314	38649	3.804	12.4	48576	3.499	13.9	59693
	13.0	18.3	75/63	99.1	41810	36302	3.675	11.4	43072	3.455	12.5	53689
			80/67	99.6	44791	37629	3.686	12.2	46052	3.466	13.3	56798
			85/71	100.1	47939	38893	3.694	13.0	49201	3.474	14.2	60064
100	6.9	5.2	75/63	116.8	38340	34688	4.404	8.7	39602	4.057	9.8	52387
			80/67	117.7	41030	36027	4.433	9.3	42292	4.086	10.4	55243
			85/71	118.6	43815	37289	4.463	9.8	45077	4.116	11.0	58175
	9.8	10.4	75/63	111.9	39255	35112	4.199	9.3	40516	3.894	10.4	52690
			80/67	112.5	42062	36465	4.216	10.0	43324	3.911	11.1	55610
			85/71	113.2	44979	37740	4.233	10.6	46241	3.928	11.8	58635
	13.0	18.3	75/63	109.0	39763	35348	4.089	9.7	41025	3.869	10.6	52862
			80/67	109.5	42587	36689	4.100	10.4	43848	3.880	11.3	55828
			85/71	110.0	45599	37982	4.110	11.1	46861	3.890	12.0	58901
110	6.9	5.2	75/63	126.6	36135	33666	4.944	7.3	37397	4.597	8.1	51847
			80/67	127.5	38682	35030	4.972	7.8	39944	4.625	8.6	54530
			85/71	128.4	41308	36318	5.001	8.3	42569	4.654	9.1	57308
	9.8	10.4	75/63	121.8	37082	34105	4.706	7.9	38344	4.401	8.7	52075
			80/67	122.4	39751	35484	4.721	8.4	41013	4.416	9.3	54831
			85/71	123.0	42485	36774	4.736	9.0	43746	4.431	9.9	57700
	13.0	18.3	75/63	118.9	37607	34348	4.577	8.2	38869	4.357	8.9	52174
			80/67	119.4	40341	35734	4.587	8.8	41603	4.367	9.5	55013
			85/71	119.9	43185	37045	4.595	9.4	44447	4.375	10.2	57934

# Heating Capacity Data – Vertical Unit Size 048

EWT	GPM	WPD	System Heating					ISO System Heating			
			EA	LWT	TOT	kW	COP	TOT	kW	COP	THA
20	6.9	5.2	60	13.3	32029	3.117	3.01	30767	2.770	3.25	22927
			70	13.6	32158	3.486	2.70	30896	3.139	2.88	21802
			80	14.0	32194	3.914	2.41	30932	3.567	2.54	20447
	9.8	10.4	60	15.1	32927	3.131	3.08	31666	2.826	3.28	23798
			70	15.3	32944	3.499	2.76	31682	3.194	2.90	22575
			80	15.6	32953	3.928	2.46	31691	3.623	2.56	21145
	13.0	18.3	60	16.2	33481	3.14	3.12	32219	2.920	3.23	24337
			70	16.4	33453	3.508	2.79	32191	3.288	2.87	23065
			80	16.6	33411	3.936	2.49	32149	3.716	2.53	21589
30	6.9	5.2	60	22.0	36441	3.19	3.34	35179	2.843	3.62	27188
			70	22.4	36364	3.56	2.99	35102	3.213	3.20	25878
			80	22.8	36317	3.992	2.66	35055	3.645	2.82	24400
	9.8	10.4	60	24.1	37532	3.209	3.42	36271	2.904	3.66	28265
			70	24.4	37372	3.579	3.06	36110	3.274	3.23	26842
			80	24.8	37242	4.011	2.72	35980	3.706	2.84	25264
	13.0	18.3	60	25.5	38227	3.221	3.48	36965	3.001	3.61	28920
			70	25.7	38011	3.591	3.10	36749	3.371	3.19	27456
			80	26.0	37827	4.024	2.75	36566	3.804	2.81	25822
40	6.9	5.2	60	30.6	41212	3.277	3.68	39950	2.930	3.99	31772
			70	31.0	40979	3.651	3.29	39717	3.304	3.52	30292
			80	31.5	40800	4.089	2.92	39538	3.742	3.09	28650
	9.8	10.4	60	33.1	42577	3.303	3.77	41316	2.998	4.04	33087
			70	33.4	42232	3.676	3.36	40971	3.371	3.56	31497
			80	33.8	41953	4.115	2.99	40691	3.810	3.13	29757
	13.0	18.3	60	34.7	43436	3.319	3.83	42174	3.099	3.98	33929
			70	34.9	43025	3.693	3.41	41763	3.473	3.52	32269
			80	35.2	42682	4.132	3.02	41420	3.912	3.10	30453
50	6.9	5.2	60	39.1	46378	3.377	4.02	45116	3.030	4.36	36703
			70	39.6	45966	3.756	3.58	44704	3.409	3.84	35044
			80	40.1	45639	4.202	3.18	44377	3.855	3.37	33255
	9.8	10.4	60	42.0	48026	3.409	4.13	46764	3.104	4.41	38294
			70	42.4	47479	3.789	3.67	46218	3.484	3.88	36496
			80	42.8	47065	4.236	3.25	45803	3.931	3.41	34575
	13.0	18.3	60	43.8	48834	3.42	4.18	47572	3.200	4.35	39366
			70	44.1	48478	3.811	3.72	47216	3.591	3.85	37430
			80	44.4	47961	4.258	3.30	46699	4.038	3.39	35421
60	6.9	5.2	60	47.5	51893	3.484	4.36	50631	3.137	4.73	41985
			70	48.1	51298	3.874	3.88	50037	3.527	4.15	40097
			80	48.7	50877	4.331	3.44	49615	3.984	3.65	38106
	9.8	10.4	60	50.8	53870	3.525	4.47	52608	3.220	4.78	43859
			70	51.2	53163	3.917	3.97	51902	3.612	4.21	41850
			80	51.7	52541	4.374	3.52	51279	4.069	3.69	39712
	13.0	18.3	60	52.9	55155	3.552	4.55	53893	3.332	4.74	45106
			70	53.2	54315	3.943	4.03	53053	3.723	4.17	42962
			80	53.6	53637	4.402	3.57	52375	4.182	3.67	40729
70	6.9	5.2	60	55.8	57719	3.606	4.69	56458	3.259	5.07	47516
			70	56.4	56981	4.001	4.17	55720	3.654	4.46	45466
			80	57.1	56318	4.472	3.69	55056	4.125	3.91	43258
	9.8	10.4	60	59.6	60096	3.656	4.81	58834	3.351	5.14	49759
			70	60.0	59198	4.054	4.28	57936	3.749	4.53	47536
			80	60.5	58367	4.527	3.78	57105	4.222	3.96	45160
	13.0	18.3	60	61.9	61308	3.68	4.88	60046	3.460	5.08	51277
			70	62.3	60582	4.087	4.34	59320	3.867	4.49	48889
			80	62.7	59648	4.561	3.83	58386	4.341	3.94	46347
80	6.9	5.2	60	64.1	63863	3.738	5.00	62601	3.391	5.41	53357
			70	64.8	62966	4.145	4.45	61704	3.798	4.76	51052
			80	65.5	62130	4.622	3.94	60869	4.275	4.17	48662
	9.8	10.4	60	68.2	66593	3.797	5.14	65331	3.492	5.48	55981
			70	68.7	65486	4.206	4.56	64224	3.901	4.82	53493
			80	69.3	64513	4.688	4.03	63251	4.383	4.23	50868
	13.0	18.3	60	70.9	68337	3.836	5.22	67075	3.616	5.43	57691
			70	71.3	67185	4.249	4.63	65923	4.029	4.79	55008
			80	71.7	65994	4.729	4.09	64732	4.509	4.20	52289
85	6.9	5.2	60	68.2	66994	3.806	5.15	65732	3.459	5.56	56370
			70	68.9	66045	4.221	4.58	64784	3.874	4.90	53973
			80	69.6	65096	4.704	4.05	63834	4.357	4.29	51416
	9.8	10.4	60	72.5	69965	3.872	5.29	68704	3.567	5.64	59165
			70	73.1	68767	4.288	4.70	67505	3.983	4.96	56552
			80	73.7	67634	4.775	4.15	66372	4.470	4.35	53793
	13.0	18.3	60	75.3	71862	3.914	5.38	70600	3.694	5.60	60962
			70	75.8	70517	4.332	4.77	69255	4.112	4.93	58206
			80	76.2	69242	4.821	4.21	67980	4.601	4.33	55253
90	6.9	5.2	60	72.2	70285	3.879	5.31	69023	3.532	5.72	59415
			70	73.0	69180	4.299	4.71	67918	3.952	5.03	56907
			80	73.8	68104	4.788	4.16	66843	4.441	4.41	54256
	9.8	10.4	60	76.9	73380	3.948	5.44	72118	3.643	5.80	62405
			70	77.4	72074	4.372	4.83	70813	4.067	5.10	59657
			80	78.0	70804	4.865	4.26	69543	4.560	4.47	56749
	13.0	18.3	60	79.8	75404	3.994	5.53	74142	3.774	5.75	64330
			70	80.2	73941	4.419	4.90	72679	4.199	5.07	61407
			80	80.7	72549	4.916	4.32	71287	4.696	4.45	58298

# Cooling Capacity Data – Vertical Unit Size 060

EWT	GPM	WPD	System Cooling					ISO System Cooling				
			EA	LWT	TOT	SEN	kW	EER	TOT	kW	EER	THR
30	8.6	7.2	75/63	48.2	65327	50593	2.600	25.1	67145	2.107	31.9	74292
			80/67	49.4	70095	52230	2.685	26.1	71913	2.192	32.8	79395
			85/71	50.7	74997	53704	2.775	27.0	76815	2.282	33.7	84677
	12.2	14.4	75/63	42.8	66024	50919	2.404	27.5	67842	1.982	34.2	74353
			80/67	43.7	70926	52587	2.487	28.5	72744	2.065	35.2	79631
			85/71	44.7	76007	54100	2.576	29.5	77825	2.154	36.1	85069
	16.3	25.7	75/63	39.6	66400	51094	2.287	29.0	68218	2.018	33.8	74355
			80/67	40.3	71379	52781	2.370	30.1	73197	2.101	34.8	79721
			85/71	41.0	76557	54317	2.460	31.1	78375	2.191	35.8	85310
40	8.6	7.2	75/63	58.1	63616	49799	3.005	21.2	65433	2.512	26.1	73839
			80/67	59.3	68106	51381	3.075	22.1	69924	2.582	27.1	78653
			85/71	60.6	72829	52858	3.151	23.1	74647	2.658	28.1	83686
	12.2	14.4	75/63	52.8	64450	50186	2.827	22.8	66267	2.405	27.6	74083
			80/67	53.7	69060	51788	2.893	23.9	70878	2.471	28.7	79042
			85/71	54.6	73935	53289	2.967	24.9	75753	2.545	29.8	84235
	16.3	25.7	75/63	49.6	64849	50372	2.722	23.8	66667	2.453	27.2	74190
			80/67	50.3	69632	52032	2.787	25.0	71450	2.518	28.4	79235
			85/71	50.9	74544	53526	2.859	26.1	76362	2.590	29.5	84501
50	8.6	7.2	75/63	68.0	61614	48875	3.391	18.2	63432	2.898	21.9	73108
			80/67	69.1	65927	50458	3.450	19.1	67745	2.957	22.9	77612
			85/71	70.3	70429	51928	3.520	20.0	72247	3.027	23.9	82427
	12.2	14.4	75/63	62.7	62514	49290	3.222	19.4	64332	2.800	23.0	73446
			80/67	63.5	66964	50896	3.277	20.4	68782	2.855	24.1	78119
			85/71	64.4	71630	52393	3.340	21.4	73448	2.918	25.2	83076
	16.3	25.7	75/63	59.6	63014	49520	3.125	20.2	64832	2.856	22.7	73637
			80/67	60.2	67537	51139	3.177	21.3	69355	2.908	23.9	78368
			85/71	60.8	72285	52646	3.239	22.3	74103	2.970	25.0	83420
60	8.6	7.2	75/63	77.8	59434	47876	3.773	15.8	61252	3.280	18.7	72007
			80/67	78.9	63540	49454	3.828	16.6	65358	3.335	19.6	76424
			85/71	80.0	67865	50942	3.889	17.5	69683	3.396	20.5	81004
	12.2	14.4	75/63	72.6	60421	48328	3.607	16.8	62239	3.185	19.5	72501
			80/67	73.4	64649	49919	3.655	17.7	66467	3.233	20.6	76949
			85/71	74.2	69117	51422	3.712	18.6	70935	3.290	21.6	81746
	16.3	25.7	75/63	69.5	60939	48566	3.512	17.4	62757	3.243	19.4	72725
			80/67	70.0	65261	50177	3.558	18.3	67079	3.289	20.4	77264
			85/71	70.7	69807	51688	3.612	19.3	71625	3.343	21.4	82100
70	8.6	7.2	75/63	87.5	57089	46809	4.167	13.7	58907	3.674	16.0	70925
			80/67	88.6	60988	48387	4.220	14.5	62806	3.727	16.9	75084
			85/71	89.6	65117	49894	4.280	15.2	66935	3.787	17.7	79460
	12.2	14.4	75/63	82.4	58092	47264	3.997	14.5	59910	3.575	16.8	71406
			80/67	83.2	62148	48871	4.042	15.4	63966	3.620	17.7	75705
			85/71	84.0	66422	50390	4.095	16.2	68240	3.673	18.6	80210
	16.3	25.7	75/63	79.3	58663	47524	3.902	15.0	60481	3.633	16.6	71684
			80/67	79.9	62790	49140	3.944	15.9	64608	3.675	17.6	76048
			85/71	80.5	67141	50665	3.993	16.8	68959	3.724	18.5	80623
80	8.6	7.2	75/63	97.2	54526	45651	4.589	11.9	56344	4.096	13.8	69667
			80/67	98.2	58316	47280	4.640	12.6	60134	4.147	14.5	73712
			85/71	99.3	62206	48792	4.704	13.2	64024	4.211	15.2	77868
	12.2	14.4	75/63	92.2	55595	46132	4.409	12.6	57413	3.987	14.4	70177
			80/67	93.0	59487	47764	4.453	13.4	61305	4.031	15.2	74327
			85/71	93.7	63572	49309	4.505	14.1	65390	4.083	16.0	78645
	16.3	25.7	75/63	89.2	56192	46403	4.309	13.0	58010	4.040	14.4	70470
			80/67	89.7	60152	48040	4.349	13.8	61970	4.080	15.2	74677
			85/71	90.3	64313	49589	4.397	14.6	66131	4.128	16.0	79064
85	8.6	7.2	75/63	102.1	53215	45061	4.817	11.0	55033	4.324	12.7	69042
			80/67	103.1	56894	46694	4.872	11.7	58712	4.379	13.4	73022
			85/71	104.1	60683	48218	4.934	12.3	62501	4.441	14.1	77124
	12.2	14.4	75/63	95.1	55004	45866	4.510	12.2	56822	4.088	13.9	70622
			80/67	97.9	58105	47193	4.674	12.4	59923	4.252	14.1	73645
			85/71	98.5	62120	48759	4.721	13.2	63938	4.299	14.9	77839
	16.3	25.7	75/63	94.1	54917	45827	4.525	12.1	56735	4.256	13.3	69894
			80/67	94.7	58785	47474	4.565	12.9	60603	4.296	14.1	73934
			85/71	95.2	62845	49033	4.613	13.6	64663	4.344	14.9	78276
90	8.6	7.2	75/63	107.0	51872	44458	5.060	10.3	53690	4.567	11.8	68500
			80/67	107.9	55461	46104	5.116	10.8	57279	4.623	12.4	72355
			85/71	108.9	59149	47642	5.179	11.4	60967	4.686	13.0	76366
	12.2	14.4	75/63	102.1	52974	44952	4.862	10.9	54792	4.440	12.3	69011
			80/67	102.8	56686	46608	4.907	11.6	58504	4.485	13.0	72949
			85/71	103.5	60530	48160	4.958	12.2	62347	4.536	13.7	77002
	16.3	25.7	75/63	99.1	53587	45228	4.751	11.3	55405	4.482	12.4	69210
			80/67	99.6	57370	46890	4.793	12.0	59188	4.524	13.1	73290
			85/71	100.1	61293	48447	4.840	12.7	63111	4.571	13.8	77398
100	8.6	7.2	75/63	116.8	49103	43221	5.595	8.8	50921	5.102	10.0	67420
			80/67	117.6	52451	44871	5.655	9.3	54269	5.162	10.5	71001
			85/71	118.6	55974	46455	5.722	9.8	57792	5.229	11.1	74808
	12.2	14.4	75/63	111.9	50235	43725	5.370	9.4	52053	4.948	10.5	67854
			80/67	112.5	53761	45407	5.419	9.9	55579	4.997	11.1	71536
			85/71	113.2	57389	46983	5.474	10.5	59207	5.052	11.7	75453
	16.3	25.7	75/63	108.9	50862	44007	5.247	9.7	52680	4.978	10.6	68030
			80/67	109.4	54461	45694	5.291	10.3	56279	5.022	11.2	71839
			85/71	109.9	58171	47275	5.341	10.9	59989	5.072	11.8	75822
110	8.6	7.2	75/63	126.5	46156	41905	6.221	7.4	47974	5.728	8.4	66368
			80/67	127.4	49318	43591	6.281	7.9	51136	5.788	8.8	69814
			85/71	128.3	52620	45205	6.354	8.3	54438	5.861	9.3	73412
	12.2	14.4	75/63	121.7	47337	42432	5.962	7.9	49155	5.540	8.9	66747
			80/67	122.3	50636	44129	6.010	8.4	52454	5.588	9.4	70289
			85/71	123.0	54091	45753	6.070	8.9	55909	5.648	9.9	74000
	16.3	25.7	75/63	118.8	47999	42728	5.822	8.2	49817	5.553	9.0	66971
			80/67	119.3	51365	44427	5.865	8.8	53182	5.596	9.5	70567
			85/71	119.8	54900	46054	5.918	9.3	56718	5.649	10.0	74331

# Heating Capacity Data – Vertical Unit Size 060

EWT	GPM	WPD	System Heating					ISO System Heating			
			EA	LWT	TOT	kW	COP	TOT	kW	COP	THA
20	8.6	7.2	60	13.3	41843	3.899	3.14	40025	3.406	3.44	30107
			70	13.6	41933	4.338	2.83	40115	3.845	3.06	28627
			80	14.0	41889	4.808	2.55	40071	4.315	2.72	26967
	12.2	14.4	60	15.1	42948	3.92	3.21	41130	3.498	3.44	31148
			70	15.3	42954	4.359	2.89	41136	3.937	3.06	29597
			80	15.6	42823	4.829	2.60	41005	4.407	2.72	27850
	16.3	25.7	60	16.2	43661	3.933	3.25	41843	3.664	3.34	31833
			70	16.4	43610	4.371	2.92	41792	4.102	2.98	30223
			80	16.6	43427	4.842	2.63	41609	4.573	2.66	28417
30	8.6	7.2	60	22.0	47601	4.003	3.48	45783	3.510	3.82	35606
			70	22.4	47487	4.445	3.13	45669	3.952	3.38	33949
			80	22.8	47328	4.925	2.81	45510	4.432	3.01	32110
	12.2	14.4	60	24.1	48954	4.027	3.56	47136	3.605	3.83	36932
			70	24.4	48740	4.468	3.19	46922	4.046	3.40	35168
			80	24.7	48484	4.948	2.87	46666	4.526	3.02	33184
	16.3	25.7	60	25.5	49828	4.041	3.61	48010	3.772	3.73	37761
			70	25.7	49546	4.483	3.24	47728	4.214	3.32	35914
			80	26.0	49225	4.964	2.90	47407	4.695	2.96	33886
40	8.6	7.2	60	30.6	53734	4.107	3.83	51916	3.614	4.21	41540
			70	31.1	53416	4.552	3.44	51598	4.059	3.72	39639
			80	31.5	53056	5.042	3.08	51238	4.549	3.30	37582
	12.2	14.4	60	33.1	55383	4.134	3.92	53565	3.712	4.23	43142
			70	33.5	54966	4.58	3.51	53149	4.158	3.74	41125
			80	33.8	54509	5.072	3.15	52691	4.650	3.32	38937
	16.3	25.7	60	34.7	56463	4.151	3.98	54645	3.882	4.12	44198
			70	35.0	55953	4.598	3.56	54135	4.329	3.66	42094
			80	35.3	55417	5.091	3.19	53599	4.822	3.25	39815
50	8.6	7.2	60	39.2	60357	4.217	4.19	58539	3.724	4.60	47893
			70	39.6	59836	4.67	3.75	58018	4.177	4.07	45751
			80	40.2	59284	5.171	3.36	57466	4.678	3.60	43455
	12.2	14.4	60	42.0	62052	4.243	4.28	60234	3.821	4.62	49902
			70	42.4	61669	4.704	3.84	59851	4.282	4.09	47544
			80	42.8	60970	5.207	3.43	59152	4.785	3.62	45086
	16.3	25.7	60	43.9	63395	4.267	4.35	61577	3.998	4.51	51134
			70	44.2	62905	4.728	3.90	61087	4.459	4.01	48713
			80	44.5	62119	5.232	3.48	60302	4.963	3.56	46152
60	8.6	7.2	60	47.6	67111	4.332	4.54	65293	3.839	4.98	54729
			70	48.1	66616	4.8	4.06	64798	4.307	4.41	52280
			80	48.7	65934	5.318	3.63	64116	4.825	3.89	49712
	12.2	14.4	60	50.9	69905	4.386	4.67	68087	3.964	5.03	57098
			70	51.3	68928	4.847	4.16	67110	4.425	4.44	54475
			80	51.7	67976	5.364	3.71	66158	4.942	3.92	51732
	16.3	25.7	60	53.0	71547	4.417	4.74	69729	4.148	4.92	58624
			70	53.3	70408	4.877	4.23	68590	4.608	4.36	55857
			80	53.7	69321	5.396	3.76	67504	5.127	3.86	52964
70	8.6	7.2	60	55.9	75076	4.485	4.90	73258	3.992	5.37	61954
			70	56.5	73983	4.954	4.37	72165	4.461	4.74	59217
			80	57.2	73014	5.487	3.90	71196	4.994	4.17	56368
	12.2	14.4	60	59.6	77964	4.543	5.03	76146	4.121	5.41	64770
			70	60.1	76725	5.017	4.48	74907	4.595	4.77	61815
			80	60.6	75569	5.552	3.99	73751	5.130	4.21	58719
	16.3	25.7	60	62.0	79944	4.584	5.11	78126	4.315	5.30	66628
			70	62.4	78487	5.058	4.54	76669	4.789	4.69	63503
			80	62.8	77156	5.594	4.04	75338	5.325	4.14	60240
80	8.6	7.2	60	64.1	82768	4.643	5.22	80950	4.150	5.71	69670
			70	64.8	81842	5.139	4.66	80024	4.646	5.04	66577
			80	65.6	80557	5.687	4.15	78739	5.194	4.44	63361
	12.2	14.4	60	68.3	86342	4.719	5.36	84524	4.297	5.76	73006
			70	68.8	85061	5.22	4.77	83243	4.798	5.08	69609
			80	69.4	83537	5.773	4.24	81719	5.351	4.47	66147
	16.3	25.7	60	71.0	88995	4.783	5.45	87177	4.514	5.66	75148
			70	71.4	87186	5.276	4.84	85368	5.007	4.99	71629
			80	71.8	85539	5.833	4.29	83722	5.564	4.41	67889
85	8.6	7.2	60	68.2	87034	4.735	5.38	85216	4.242	5.88	73653
			70	69.0	85934	5.243	4.80	84117	4.750	5.19	70382
			80	69.7	84488	5.801	4.26	82670	5.308	4.56	67029
	12.2	14.4	60	72.6	90845	4.826	5.51	89027	4.404	5.92	77239
			70	73.2	89408	5.336	4.91	87590	4.914	5.22	73646
			80	73.8	87700	5.899	4.35	85882	5.477	4.59	69983
	16.3	25.7	60	75.4	93335	4.888	5.59	91517	4.619	5.80	79596
			70	75.9	91706	5.4	4.97	89888	5.131	5.13	75782
			80	76.4	89869	5.968	4.41	88051	5.699	4.52	71881
90	8.6	7.2	60	72.3	91630	4.846	5.54	89812	4.353	6.04	77720
			70	73.1	90140	5.356	4.93	88322	4.863	5.32	74266
			80	73.9	88516	5.924	4.38	86698	5.431	4.67	70731
	12.2	14.4	60	76.9	95892	4.955	5.67	94074	4.533	6.08	81526
			70	77.5	93865	5.462	5.03	92047	5.040	5.35	77763
			80	78.1	92054	6.039	4.46	90236	5.617	4.70	73890
	16.3	25.7	60	79.9	97930	5.008	5.73	96112	4.739	5.94	84156
			70	80.4	96358	5.537	5.10	94540	5.268	5.26	80054
			80	80.9	94317	6.116	4.52	92499	5.847	4.63	76004

# Vertical Performance Data – Operating Limits

## Air Limits - °F (English units)

	Standard Units		Extended Range Units	
	Cooling	Heating	Cooling	Heating
Min Ambient Air	50°F	50°F	40°F	40°F
Normal Ambient Air	80°F	70°F	80°F	70°F
Max Ambient Air	100°F	85°F	100°F	85°F
Min Ent Air ①, ②	50°F	50°F	50°F	40°F
Normal Ent Air db/wb	80/67°F	70°F	80/67°F	70°F
Max Ent Air db/wb ①, ②	100/83°F	80°F	100/83°F	80°F

## Air Limits - °C (SI units)

	Standard Units		Extended Range Units	
	Cooling	Heating	Cooling	Heating
Min Ambient Air	10°C	10°C	5°C	5°C
Normal Ambient Air	27°C	21°C	27°C	21°C
Max Ambient Air	38°C	29°C	38°C	29°C
Min Ent Air ①, ②	10°C	10°C	10°C	5°C
Normal Ent Air db/wb	27/19°C	21°C	27/19°C	21°C
Max Ent Air db/wb ①, ②	38/28°C	27°C	38/28°C	27°C

## Water - °F (English units)

	Standard Units		Extended Range Units	
	Cooling	Heating	Cooling	Heating
Min Ent Water ①, ②	55°F	55°F	30°F	20°F
Normal Ent Water	85°F	70°F	77°F	40°F
Max Ent Water	110°F	90°F	110°F	90°F

## Water - °C (SI units)

	Standard Units		Extended Range Units	
	Cooling	Heating	Cooling	Heating
Min Ent Water ①, ②	13°C	13°C	-1°C	-6°C
Normal Ent Water	29°C	21°C	25°C	4°C
Max Ent Water	43°C	21°C	43°C	32°C

① At ARI flow rate

② Maximum and minimum values may not be combined. If one value is at maximum or minimum, the other two conditions may not exceed the normal condition for standard units. Extended range units may combine any two maximum conditions, but not more than two, with all other conditions being normal conditions.

## Environment

This equipment is designed for indoor installation only. Sheltered locations such as attics, garages, etc., generally will not provide sufficient protection against extremes in temperature and/or humidity, and equipment performance, reliability, and service life may be adversely affected.

## Power supply

A voltage variation of +10% of nameplate utilization voltage is acceptable. Three-phase system imbalance shall not exceed 2%.

## Additional information for initial start-up only

### Standard units:

Units are designed to start in an ambient of 50°F (10°C), with entering air at 50°F (10°C), with entering water at 70°F (21°C), with both air and water at the flow rates used in the ARI Standard 320-86 rating test, for initial start-up in winter.

**Note:** This is not a normal or continuous operating condition. It is assumed that such a start-up is for the purpose of bringing the building space up to occupancy temperature.

### Extended range units:

Extended range heat pump conditioners are designed to start in an ambient of 40°F (5°C), with entering air at 40°F (5°C), with entering water at 40°F (5°C), with both air and water at the flow rates used in the ARI Standard 320-86 rating test, for initial start-up in winter.

**Note:** This is not a normal or continuous operating condition. It is assumed that such a start-up is for the purpose of bringing the building space up to occupancy temperature.

# Vertical Correction Factors

## Airflow Correction Factors

	Percent of Nominal Airflow						
	85	90	95	100	105	110	115
Total Cooling Capacity	0.972	0.982	0.993	1.00	1.007	1.010	1.013
Sensible Cooling Capacity	0.926	0.948	0.974	1.00	1.027	1.055	1.066
kW - Cooling	0.977	0.984	0.993	1.00	1.011	1.018	1.028
Total Heat of Rejection	0.975	0.983	0.991	1.00	1.008	1.015	1.018
Total Heating Capacity	0.967	0.978	0.990	1.00	1.009	1.017	1.024
kW - Heating	1.009	1.006	1.003	1.00	0.997	0.995	0.993
Total Heat of Absorption	0.967	0.976	0.989	1.00	1.010	1.019	1.025

## Antifreeze Correction Factors

### Ethylene Glycol

	10%	20%	30%	40%	50%
Cooling Capacity	0.9950	0.9920	0.9870	0.9830	0.9790
Heating Capacity	0.9910	0.9820	0.9770	0.9690	0.9610
Pressure Drop	1.0700	1.1300	1.1800	1.2600	1.2800

### Propylene Glycol

	10%	20%	30%	40%	50%
Cooling Capacity	0.9900	0.9800	0.9700	0.9600	0.9500
Heating Capacity	0.9870	0.9750	0.9620	0.9420	0.9300
Pressure Drop	1.0700	1.1500	1.2500	1.3700	1.4200

### Methanol

	10%	20%	30%	40%	50%
Cooling Capacity	0.9980	0.9720	–	–	–
Heating Capacity	0.9950	0.9700	–	–	–
Pressure Drop	1.0230	1.0570	–	–	–

### Ethanol

	10%	20%	30%	40%	50%
Cooling Capacity	0.9910	0.9510	–	–	–
Heating Capacity	0.9950	0.9600	–	–	–
Pressure Drop	1.0350	0.9600	–	–	–

# Vertical Electrical Data

Unit Size	Power Voltage-Phase-Hz	Compressor		Fan Motor	Total Unit	Minimum Voltage	Min. Circuit Ampacity	Max. Fuse Size
		RLA	LRA	FLA	FLA			
007	115-1-60	7.5	40.0	0.94	8.5	104	10.4	15.0
	208/230-1-60	4.0	19.0	0.46	4.5	197	5.5	15.0
	265-1-60	3.1	16.0	0.38	3.5	240	4.3	15.0
	230-1-50	3.1	16.0	0.46	3.6	197	4.4	15.0
009	115-1-60	9.5	44.0	1.88	11.4	104	13.8	20.0
	208/230-1-60	5.1	20.0	0.83	5.9	197	7.2	15.0
	265-1-60	3.9	18.6	0.65	4.6	240	5.6	15.0
	230-1-50	3.9	18.6	0.81	4.8	197	5.7	15.0
012	115-1-60	12.5	54.0	1.88	14.4	104	17.5	25.0
	208/230-1-60	6.7	26.3	0.83	7.5	197	9.2	15.0
	265-1-60	5.2	28.0	0.65	5.8	240	7.1	15.0
	230-1-50	5.2	28.0	0.81	6.0	197	7.3	15.0
019	208/230-1-60	8.4	48.0	3.00	11.4	197	13.5	20.0
	265-1-60	7.1	44.0	3.00	10.1	240	11.8	15.0
	230-1-50	7.1	44.0	3.00	10.1	197	11.8	15.0
024	208/230-1-60	10.4	48.0	3.00	13.4	197	16.0	25.0
	265-1-60	8.0	44.0	3.00	11.0	240	13.0	20.0
	208/230-3-60	6.4	58.0	3.00	9.4	197	11.0	15.0
	460-3-60	3.5	30.0	1.70	5.2	416	6.1	15.0
	230-1-50	8.0	44.0	3.00	11.0	197	13.0	20.0
030	208/230-1-60	14.7	72.5	3.00	17.7	197	21.4	35.0
	265-1-60	12.5	61.0	3.00	15.5	240	18.6	30.0
	208/230-3-60	10.4	63.0	3.00	13.4	197	16.1	25.0
	460-3-60	4.5	31.0	1.70	6.2	416	7.3	15.0
	380-3-50	4.5	31.0	1.70	6.2	342	7.3	15.0
036	208/230-1-60	15.8	83.0	3.50	19.3	197	23.3	35.0
	265-1-60	15.4	83.0	2.80	18.2	240	22.0	35.0
	208/230-3-60	11.5	77.0	3.50	15.0	197	17.9	25.0
	460-3-60	5.1	35.0	1.60	6.7	416	8.0	15.0
	380-3-50	5.1	35.0	1.60	6.7	342	8.0	15.0
042	208/230-1-60	19.2	104.0	3.40	22.6	197	27.4	45.0
	208/230-3-60	13.5	88.0	3.40	16.9	197	20.2	30.0
	460-3-60	7.1	46.0	1.50	8.6	416	10.3	15.0
	575-3-60	5.0	34.0	1.60	6.6	520	7.9	15.0
	380-3-50	6.4	43.0	1.50	7.9	342	9.5	15.0
048	208/230-1-60	23.1	134.0	5.30	28.4	197	34.1	50.0
	208/230-3-60	16.0	91.0	5.30	21.3	197	25.3	40.0
	460-3-60	7.1	46.0	2.00	9.1	416	10.8	15.0
	575-3-60	5.6	37.0	1.80	7.4	520	8.8	15.0
	380-3-50	7.1	43.0	2.00	9.1	342	10.8	15.0
060	208/230-1-60	27.6	158.0	5.30	32.9	197	39.8	60.0
	208/230-3-60	18.1	137.0	5.30	23.4	197	28.0	45.0
	460-3-60	9.0	62.0	2.00	11.0	416	13.2	20.0
	575-3-60	7.6	50.0	1.80	9.4	520	11.3	15.0
	380-3-50	9.0	62.0	2.00	11.0	342	13.2	20.0

1. 208-230 volt units (60 Hz) are shipped for 208 volt operation; for 230 volt operation, the tap on the 24 volt transformer must be changed from the 208 volt tap to the 230 volt tap.
2. Maximum time delay (Class 5) fuse or HACR type circuit breaker: values are amps. HACR circuit breakers may only be available for 208 and 230 volt single phase operation.



# Enfinity Vertical General Data

## Physical Data

Unit Size	007	009	012	019	024
Fan Wheel - D x W (In.)	6.3 x 6.0	6.3 x 6.0	6.2 x 7.4	9.5 x 7.1	9.5 x 7.1
Fan Motor Horsepower	1/20	1/8	1/8	1/3	1/3
Coil Face Area (Sq. Ft.)	.97	1.17	1.17	2.75	2.75
Coil Rows	3	3	3	3	3
Refrigerant Charge (Oz.)	14.3	17	18	33	37
Filter, (Qty.) Size (In.)	(1) 12 x 20			(1) 22 x 22	
Water Connections, Female NPT (In.)	1/2	1/2	1/2	1/2	1/2
Condensate Connections, Female NPT (In.)	3/4	3/4	3/4	3/4	3/4
Weight, Operate (Lbs.)	113	113	113	213	213
Weight, Shipping (Lbs.)	135	135	135	232	232

Unit Size	030	036	042	048	060
Fan Wheel - D x W (In.)	9.5 x 7.1	9.5 x 7.1	12.9 x 11.1	12.9 x 11.1	12.9 x 11.1
Fan Motor Horsepower	1/3	1/2	1/2	3/4	3/4
Coil Face Area (Sq. Ft.)	3.5	3.5	4.42	4.42	6.63
Coil Rows	3	3	3	3	3
Refrigerant Charge (Oz.)	43	45	57	51	78
Filter, (Qty.) Size (In.)	(1) 24 x 24		(1) 24 x 30		(2) 17.5 x 30.25
Water Connections, Female NPT (In.)	3/4	3/4	3/4	3/4	3/4
Condensate Connections, Female NPT (In.)	3/4	3/4	3/4	3/4	3/4
Weight, Operate (Lbs.)	224	224	310	310	384
Weight, Shipping (Lbs.)	243	243	331	331	403

## Fan Performance

60 cycle, 208 volts, single phase (includes allowance for dry coil and filter)

Size	Speed	0.10	0.15	0.20	0.25	0.30	0.35	0.40	0.45	0.50	0.55	0.60	0.65	0.70	0.75
007	*High	310	300	300	290	280	270	250	240	230	210	190	170	-	-
009	*High	460	450	440	430	420	410	400	380	360	340	320	310	-	-
012	Low	370	360	350	340	330	320	310	290	270	250	230	-	-	-
012	*High	480	470	450	440	420	410	390	380	360	330	310	290	-	-
019	*Low	1020	1000	990	980	960	940	920	900	870	840	800	750	670	600
019	High	1220	1200	1180	1160	1130	1110	1070	1040	1010	970	930	880	810	730
024	Low	1030	1020	1000	980	950	930	900	880	850	810	770	720	670	620
024	*High	1180	1160	1130	1100	1060	1030	1000	970	940	900	860	820	760	700
030	Low	-	-	-	980	970	970	950	940	920	900	880	850	810	750
030	*High	1230	1220	1220	1210	1200	1190	1170	1140	1120	1100	1060	1020	980	930
036	Low	-	-	1230	1210	1200	1180	1160	1140	1110	1080	1050	1010	950	890
036	*High	1510	1500	1490	1480	1470	1440	1400	1360	1320	1270	1220	1170	1110	1050
042	*High	2150	2140	2120	2090	2060	2010	1950	1890	1830	1700	1440	1220	1100	-
048	*Low	-	-	-	-	1990	1970	1930	1880	1830	1770	1700	1550	1280	-
048	High	2390	2350	2300	2260	2220	2190	2160	2110	2040	1970	1880	1790	1700	-
060	Low	-	-	-	-	-	-	1990	1970	1930	1890	1830	1730	1490	-
060	*High	2530	2520	2510	2490	2460	2430	2400	2360	2310	2250	2170	2090	1960	-

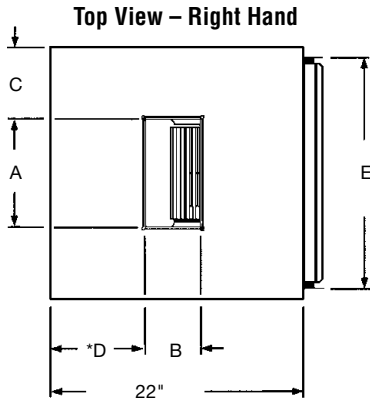
\* Above fan selections are as wired from the factory.

For wet coil, calculate face velocity (cfm/ coil face area, sq. ft.). Add the following static to the external static pressure for the corresponding face velocity: 300 fpm = 0.05", 400 fpm = 0.10", 500 fpm = 0.14". Re-enter table at the increased external static pressure to determine final cfm.

# Dimensional Data – Vertical Size 007, 009, 012

## Right Hand and Left Hand Return

Right and Left Hand Return determined by facing the water connection side of the unit.

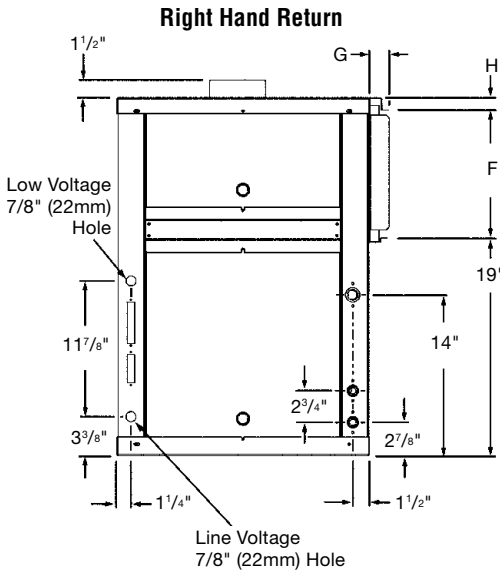
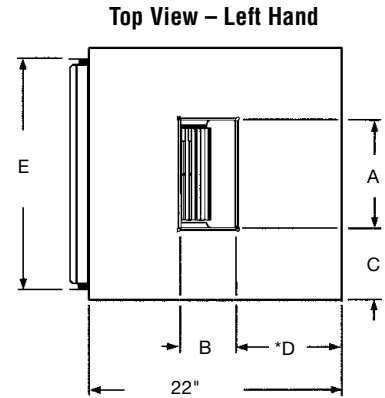


NOTE: Dimensions are approximate

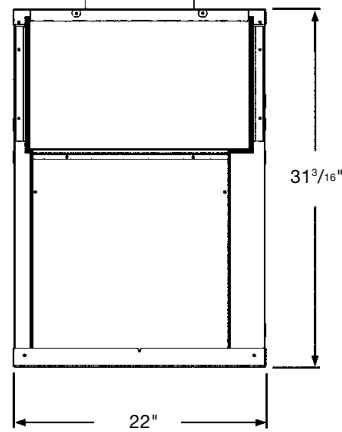
Unit Size	Discharge Duct Dims		
	A	B	C
007-009	7 <sup>9</sup> / <sub>16</sub> "	4 <sup>13</sup> / <sub>16</sub> "	7 <sup>1</sup> / <sub>4</sub> "
012	9 <sup>1</sup> / <sub>2</sub> "	4 <sup>13</sup> / <sub>16</sub> "	6 <sup>1</sup> / <sub>4</sub> "

\* Right Hand - Dimension "D" = 8<sup>1</sup>/<sub>8</sub>"

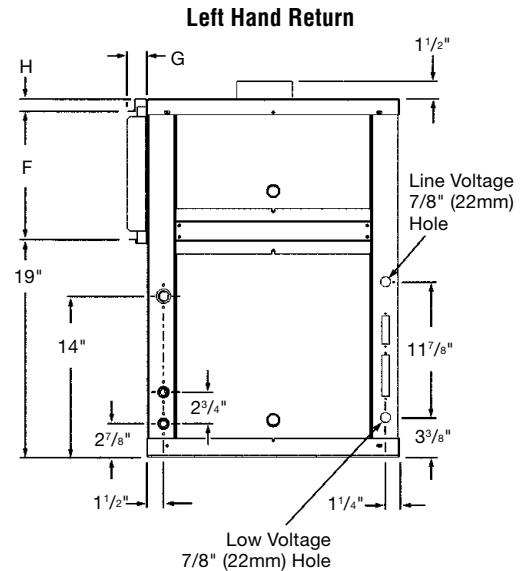
\* Left Hand - Dimension "D" = 9<sup>1</sup>/<sub>16</sub>"



### Filter (Side View)



Overall Unit Dimensions = 22"W x 22"L x 31<sup>3</sup>/<sub>16</sub>"H



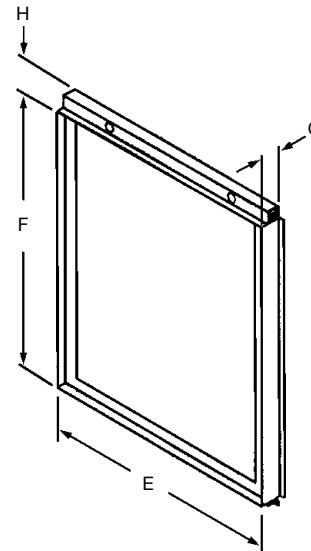
## Return Air Duct Collar / Filter Rack

### Standard 1"

UNIT SIZE	E	F	G	H
007, 009, 012	20" (508mm)	11 <sup>3</sup> / <sub>16</sub> " (284mm)	1 <sup>11</sup> / <sub>16</sub> " (42mm)	1" (25mm)

### Optional 2"

UNIT SIZE	E	F	G	H
007, 009, 012	20" (508mm)	11 <sup>3</sup> / <sub>16</sub> " (284mm)	2 <sup>11</sup> / <sub>16</sub> " (68mm)	1" (25mm)

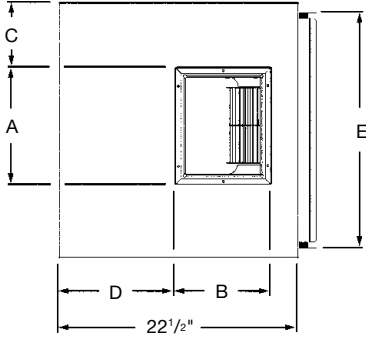


# Dimensional Data – Vertical Size 019 & 024

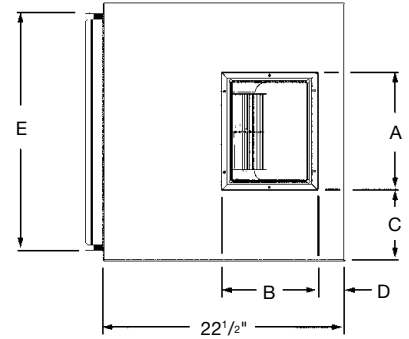
## Right Hand and Left Hand Return

Right and Left Hand Return determined by facing the water connection side of the unit.

Top View – Right Hand



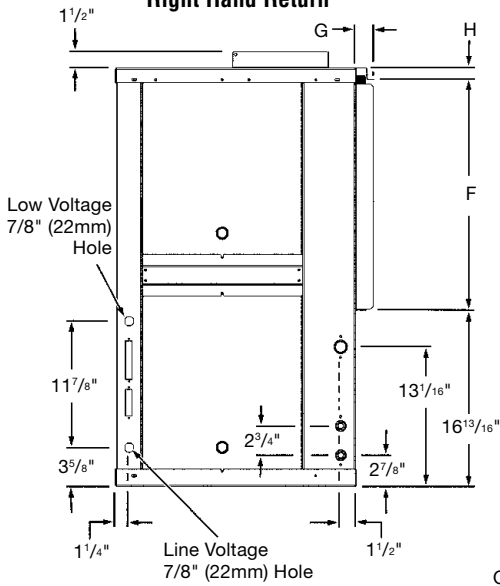
Top View – Left Hand



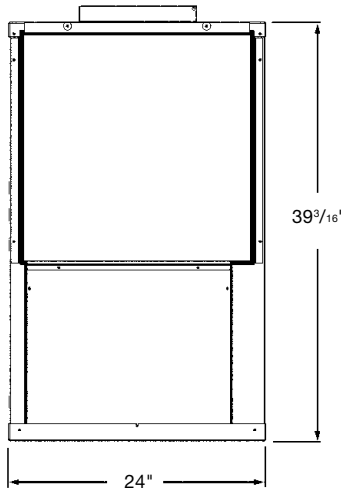
NOTE: Dimensions are approximate

Discharge Duct Dimensions				
Right Hand	A	B	C	D
	11"	9"	6 1/2"	11"
Left Hand	A	B	C	D
	11"	9"	6 1/2"	2 1/2"

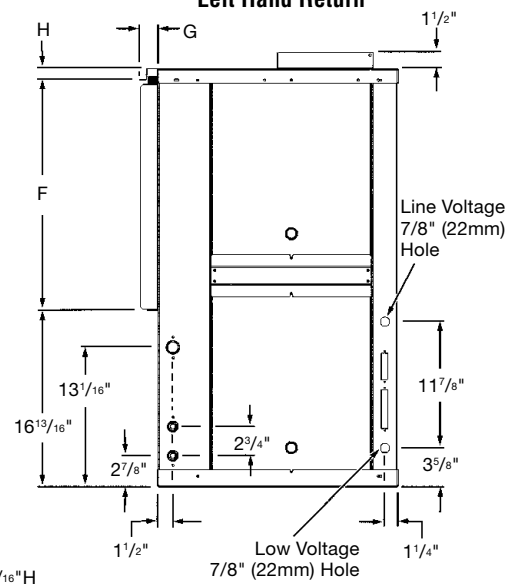
Right Hand Return



Filter (Side) View



Left Hand Return



Overall Unit Dimensions = 22 1/2"W x 24"L x 39 3/16"H

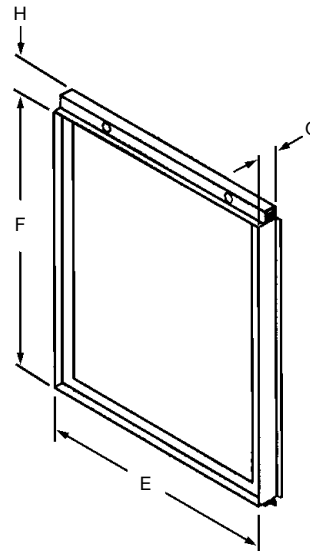
## Return Air Duct Collar / Filter Rack

### Standard 1"

UNIT SIZE	E	F	G	H
019 & 024	22" (559mm)	21 1/4" (540mm)	1 11/16" (43mm)	1" (25mm)

### Optional 2"

UNIT SIZE	E	F	G	H
019 & 024	22" (559mm)	21 1/4" (540mm)	2 11/16" (68mm)	1" (25mm)

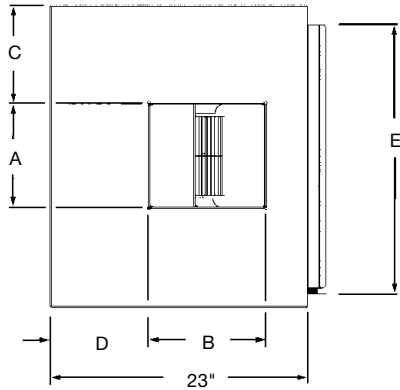


# Dimensional Data – Vertical Size 030 & 036

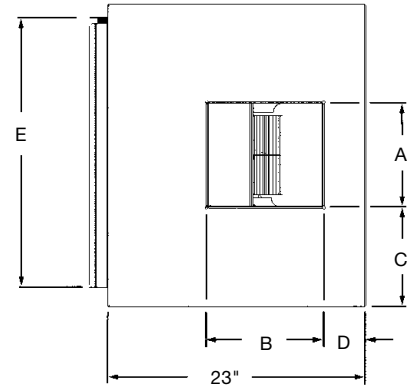
## Right Hand and Left Hand Return

Right and Left Hand Return determined by facing the water connection side of the unit.

Top View – Right Hand



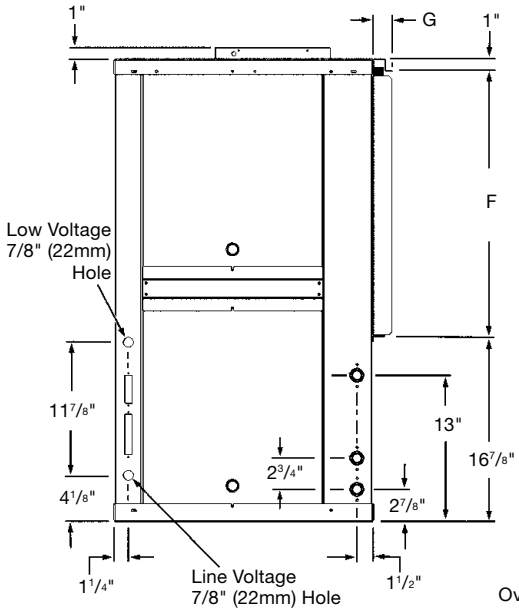
Top View – Left Hand



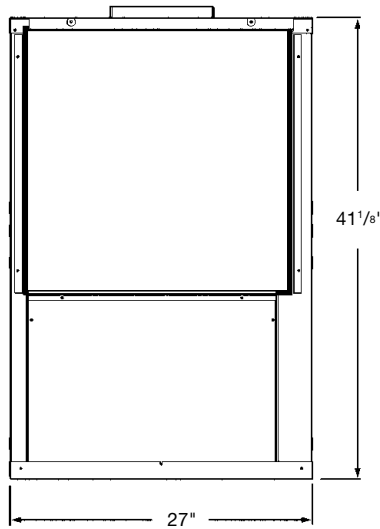
NOTE: Dimensions are approximate

Discharge Duct Dimensions				
	A	B	C	D
Right Hand	9 <sup>5</sup> / <sub>16</sub> "	10 <sup>1</sup> / <sub>4</sub> "	8 <sup>13</sup> / <sub>16</sub> "	8 <sup>15</sup> / <sub>16</sub> "
Left Hand	9 <sup>5</sup> / <sub>16</sub> "	10 <sup>1</sup> / <sub>4</sub> "	8 <sup>15</sup> / <sub>16</sub> "	3 <sup>7</sup> / <sub>8</sub> "

Right Hand Return

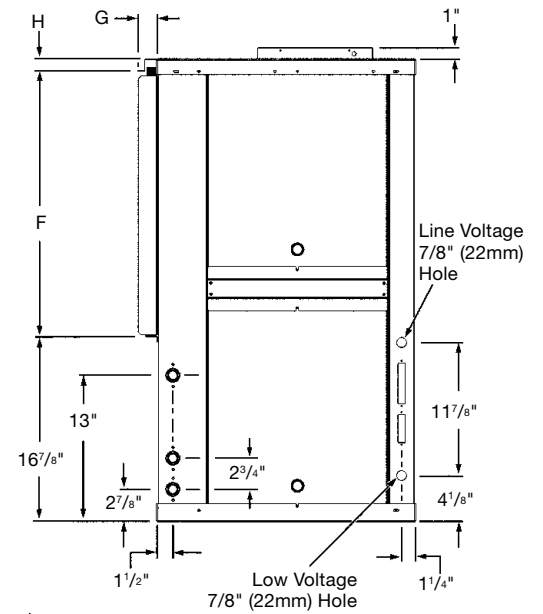


Filter (Side) View



Overall Unit Dimensions = 23"W x 27"L x 41 1/8"H

Left Hand Return



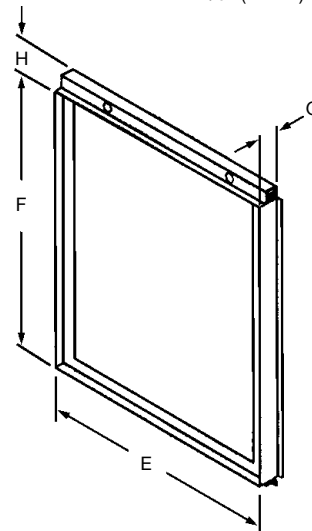
## Return Air Duct Collar / Filter Rack

### Standard 1"

UNIT SIZE	E	F	G	H
030 & 036	24" (610mm)	23 <sup>1</sup> / <sub>4</sub> " (591mm)	1 <sup>11</sup> / <sub>16</sub> " (43mm)	1" (25mm)

### Optional 2"

UNIT SIZE	E	F	G	H
030 & 036	24" (610mm)	23 <sup>1</sup> / <sub>4</sub> " (591mm)	2 <sup>11</sup> / <sub>16</sub> " (68mm)	1" (25mm)

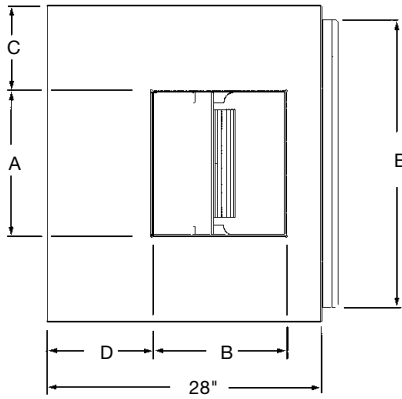


# Dimensional Data – Vertical Size 042 & 048

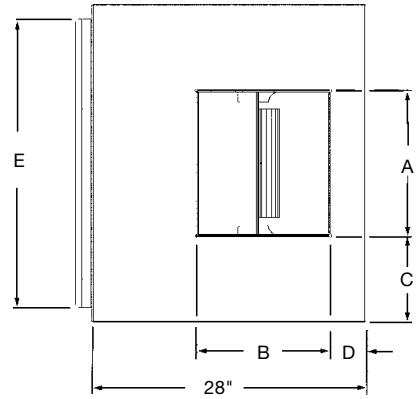
## Right Hand and Left Hand Return

Right and Left Hand Return determined by facing the water connection side of the unit.

Top View – Right Hand



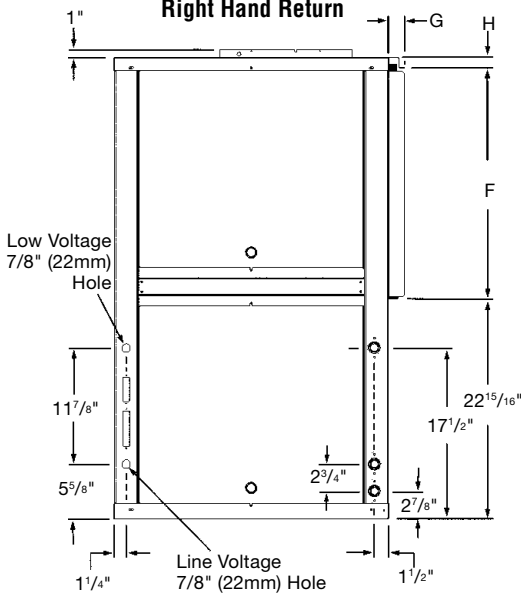
Top View – Left Hand



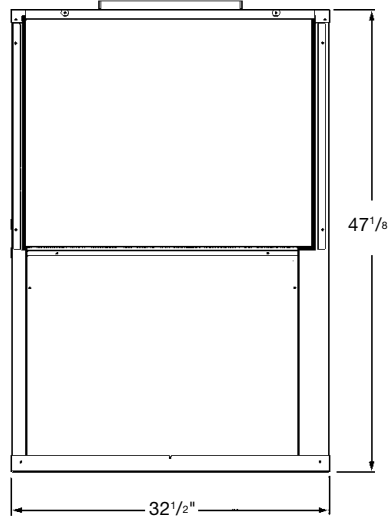
NOTE: Dimensions are approximate

Discharge Duct Dimensions				
Right Hand	A	B	C	D
	14 <sup>11</sup> / <sub>16</sub> "	13 <sup>7</sup> / <sub>16</sub> "	8 <sup>15</sup> / <sub>16</sub> "	10 <sup>15</sup> / <sub>16</sub> "
Left Hand		13 <sup>7</sup> / <sub>16</sub> "	8 <sup>15</sup> / <sub>16</sub> "	3 <sup>3</sup> / <sub>4</sub> "

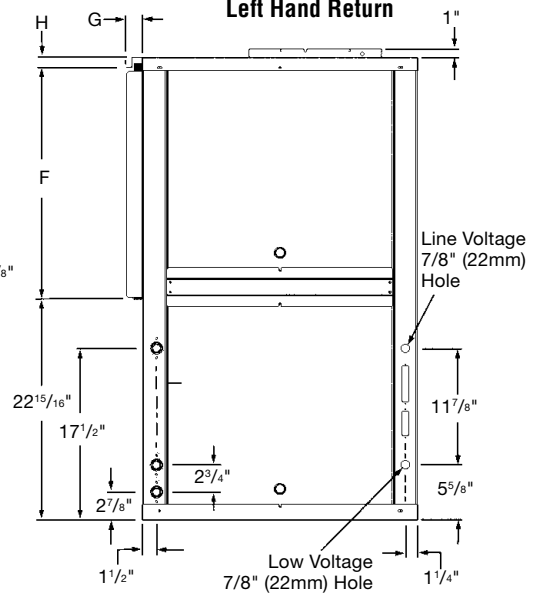
Right Hand Return



Filter (Side) View



Left Hand Return



Overall Unit Dimensions = 28"W x 32<sup>1</sup>/<sub>2</sub>"L x 47<sup>1</sup>/<sub>8</sub>"H

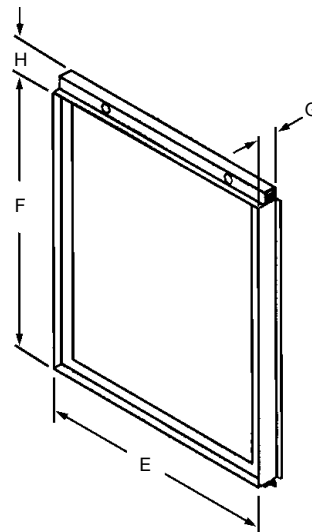
## Return Air Duct Collar / Filter Rack

### Standard 1"

UNIT SIZE	E	F	G	H
042 & 048	30 <sup>5</sup> / <sub>16</sub> " (770mm)	22 <sup>13</sup> / <sub>16</sub> " (579mm)	1 <sup>11</sup> / <sub>16</sub> " (20mm)	1 <sup>7</sup> / <sub>16</sub> " (37mm)

### Optional 2"

UNIT SIZE	E	F	G	H
042 & 048	30 <sup>5</sup> / <sub>16</sub> " (770mm)	22 <sup>13</sup> / <sub>16</sub> " (579mm)	2 <sup>11</sup> / <sub>16</sub> " (68mm)	1 <sup>7</sup> / <sub>16</sub> " (37mm)

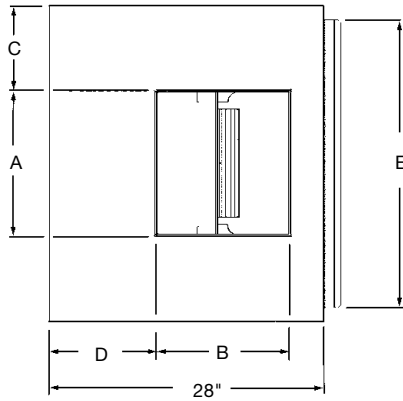


# Dimensional Data – Vertical Size 060

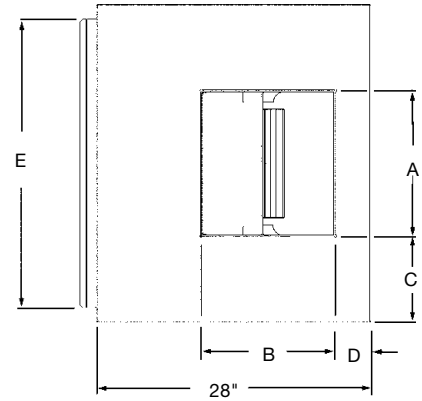
## Right Hand and Left Hand Return

Right and Left Hand Return determined by facing the water connection side of the unit.

Top View – Right Hand

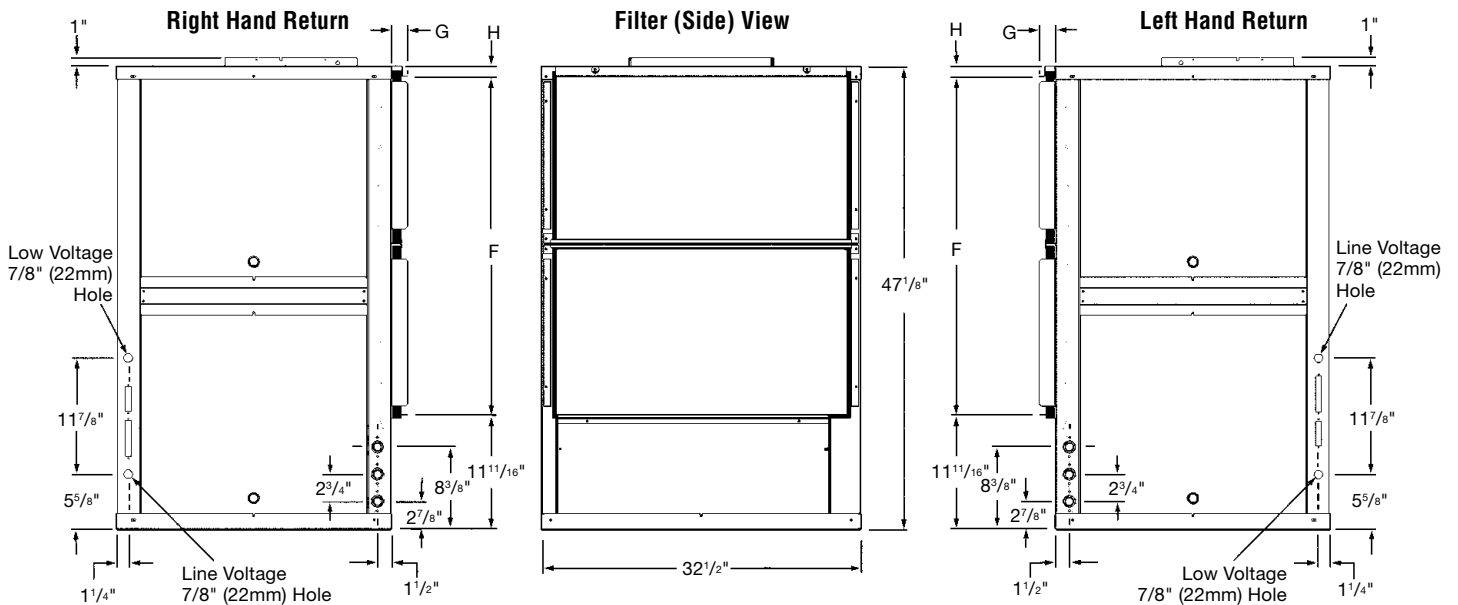


Top View – Left Hand



NOTE: Dimensions are approximate

Discharge Duct Dimensions				
Right Hand	A	B	C	D
	14 <sup>11</sup> / <sub>16</sub> "	13 <sup>7</sup> / <sub>16</sub> "	8 <sup>15</sup> / <sub>16</sub> "	10 <sup>15</sup> / <sub>16</sub> "
Left Hand		13 <sup>7</sup> / <sub>16</sub> "	8 <sup>15</sup> / <sub>16</sub> "	3 <sup>3</sup> / <sub>4</sub> "



Overall Unit Dimensions = 28"W x 32<sup>1</sup>/<sub>2</sub>"L x 47<sup>1</sup>/<sub>8</sub>"H

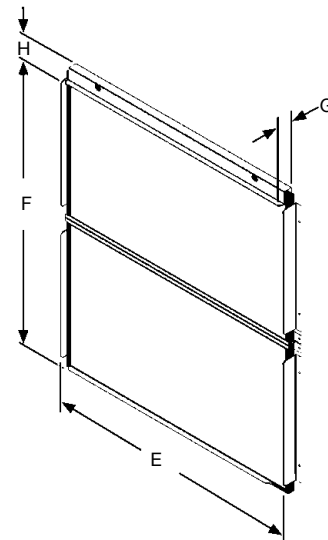
## Return Air Duct Collar / Filter Rack

### Standard 1"

UNIT SIZE	E	F	G	H
060	30 <sup>1</sup> / <sub>2</sub> " (774mm)	34" (864mm)	1 <sup>11</sup> / <sub>16</sub> " (20mm)	1 <sup>7</sup> / <sub>16</sub> " (36mm)

### Optional 2"

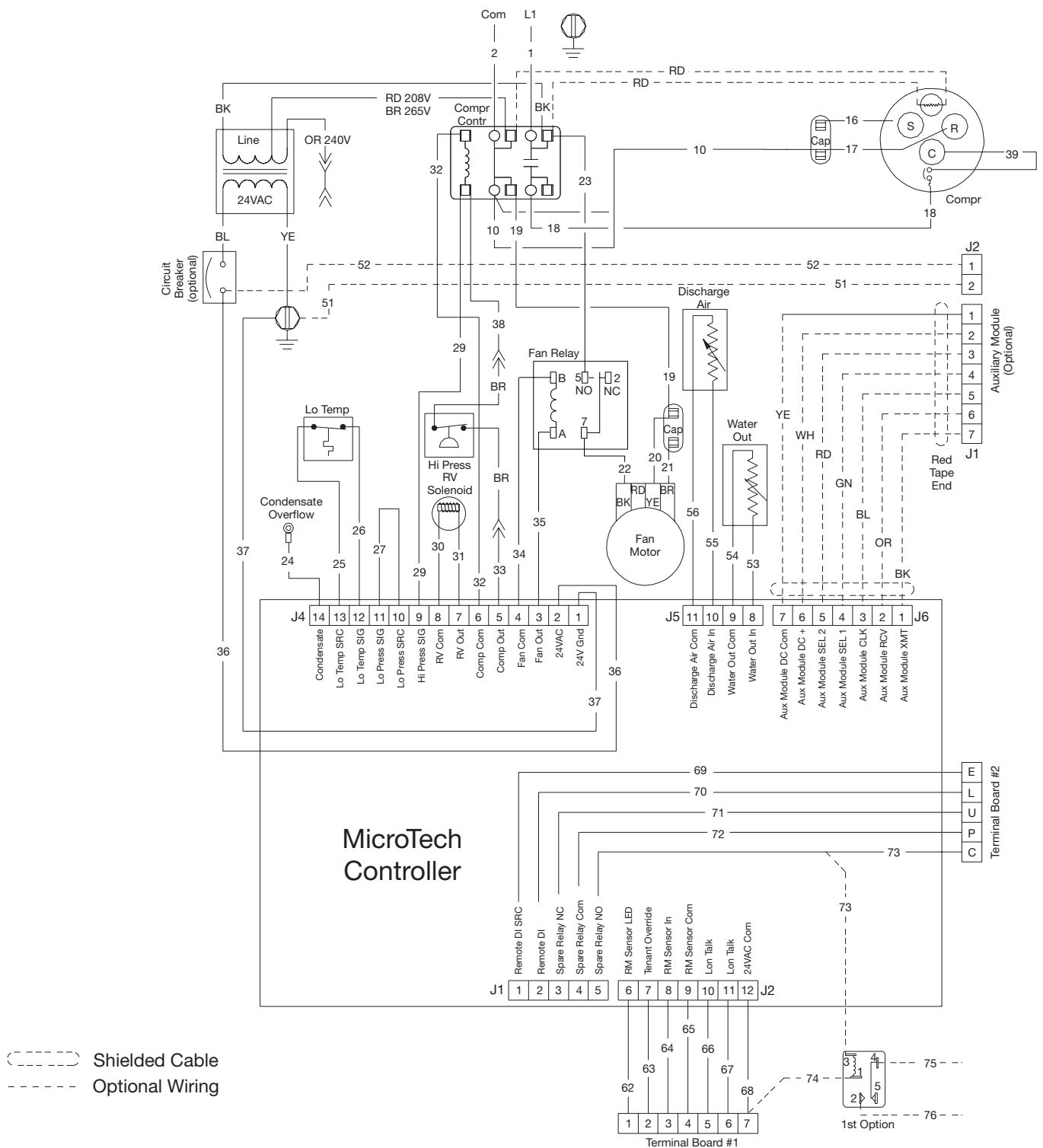
UNIT SIZE	E	F	G	H
060	30 <sup>1</sup> / <sub>2</sub> " (774mm)	34" (864mm)	2 <sup>11</sup> / <sub>16</sub> " (68mm)	1 <sup>7</sup> / <sub>16</sub> " (36mm)





# Typical Wiring Diagrams

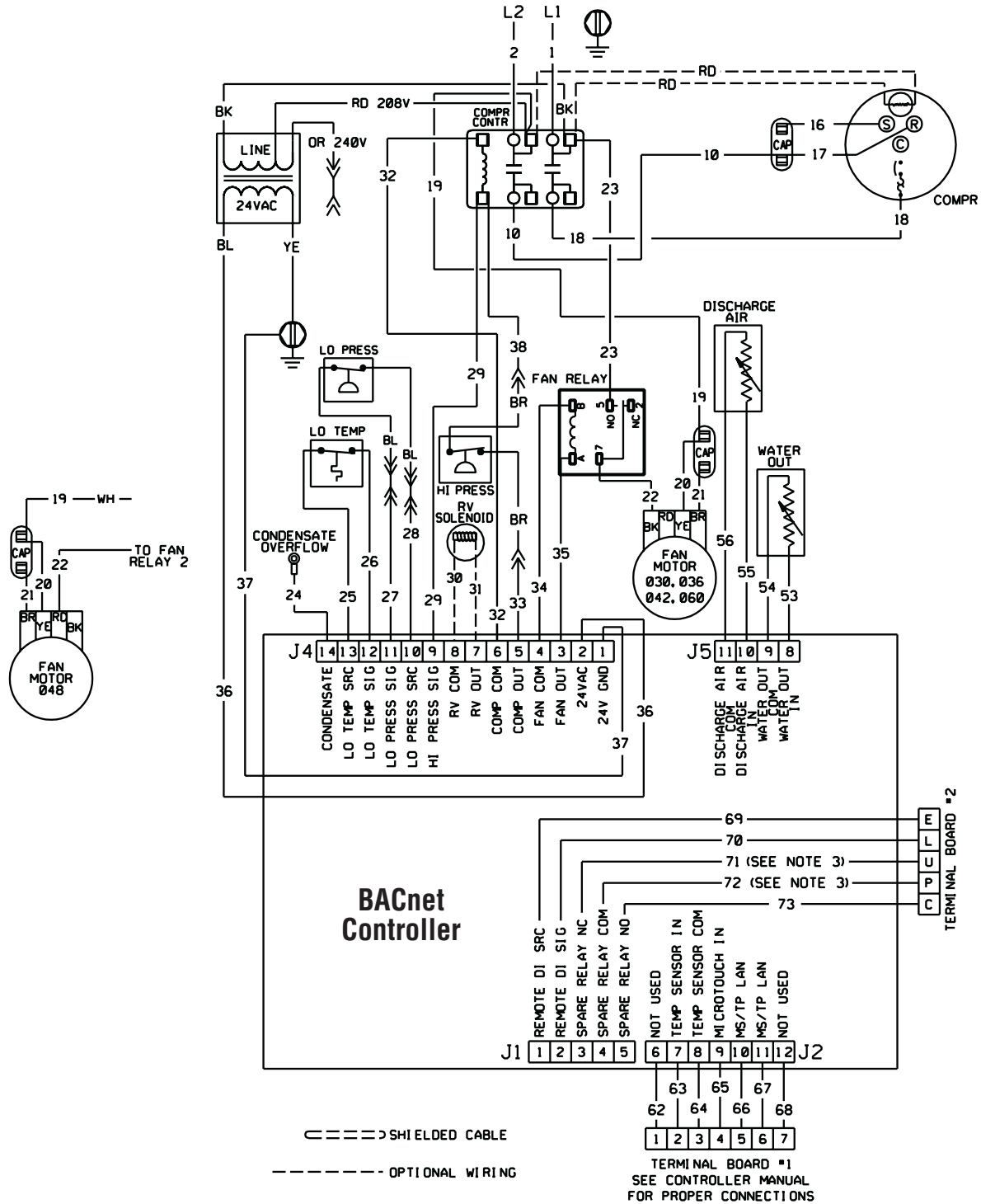
## MicroTech™ 2000 unit wiring diagram, 007 thru 060





# Typical Wiring Diagrams

## BACnet® unit wiring diagram, 007 thru 060



# Accessories – Field Installed

Wall mounted thermostats are available for Mark IV/AC units in automatic or manual changeover styles. All include a fan switch for constant “on” operation or “automatic” for cycle operation with the compressor. All thermostats are 24-volt type and have dual Fahrenheit and Celsius temperature setpoint scales. Thermostat accessories include universal guard and locking cover. Individual thermostats include:

## Standard Manual Changeover

Single setpoint lever for one-stage heating and cooling. System “heat-off-cool” switch and fan “on-off” switch.



## Standard Manual & Automatic Changeover

Dual setpoint levers for one-stage or two-stage heating or cooling operation. System “heat-off-auto-cool” switch and fan “on-auto” switch. Includes LED for “fault.”



## Deluxe Automatic Changeover

Dual setpoint levers for one-stage or two-stage heating or cooling, with night setback operation. Night setback temperature setpoint is 12°F (-6.6°C) below daytime heat setting. System “off-auto” switch and fan “on-auto” switch. Override switch (spring loaded fan switch) puts unit back into occupied daytime heat and cool setpoints. Includes LED for “fault.”



## Programmable Micro-electronic Manual & Automatic Changeover

This thermostat can be wired for either one-stage or two-stage unit operation, and is complete and ready for installation. Liquid Crystal display (LCD) is backlit and easy to read. Selectable F or C temperature display, automatic or manual changeover as well. Setpoints are permanently held in memory (no batteries used) and retained during power outages. Display updates every minute. Features include 7-day programmability, four settings per day, keyboard lock code, time delay and adjustable deadband. System “heat-auto-cool-off” and fan “on-auto” switches.



## Non-programmable Electronic Manual & Automatic Changeover

This thermostat can be wired for either one-stage or two-stage unit operation, and is complete and ready for installation. Liquid Crystal display (LCD) is backlit and easy to read. Selectable F or C temperature display, automatic or manual changeover as well. Setpoints are permanently held in memory (no batteries used) and retained during power outages. Display updates every minute.



# Accessories – Field Installed

## 7-Day Programmable Electronic Thermostat

This hard wired electronic thermostat is selectable for either two-stage heat, two-stage cool or two stage heat pump and auto changeover operation. 7-day programming – program each day individually (four time/temperature changes) or program one day and copy the entire week. Features include, large backlit Liquid Crystal Display (LCD) and precise temperature display. Auto or manual changeover, programmable fan, key pad lockout, adjustable deadband, integral four minute anti-short cycle protection, and is Title 24 compliant. A Remote wall sensor is available with this thermostat

### *7-day Programmable Thermostat with Remote Wall Sensor*



## Supply and Return Water Hoses

Available as fire rated construction in 2 or 3 foot (610 mm or 914 mm) lengths. Fire rated hoses have a synthetic polymer core with an outer rated covering of galvanized steel. Fittings are steel. Assembly is “fire rated” and tested according to UL 94 with a VO rating and ASTM 84. Each hose has MPT connections. Fire rated hoses have a swivel connection at one end. Hoses are available in 3/4" (19 mm) to match the FPT fittings on the unit.

### *Supply and Return Water Hoses*



## Condensate Hose Kit

Available as a long clear plastic hose with the necessary clamps and a MPT hose fitting for connection to the FPT field piping.

### *Condensate Hose Kit*



# Accessories – Field Installed

## Combination Balancing and Shutoff (ball) Valves

Constructed of brass and rated at 400 psig (2758 kPa) maximum working pressure. Valves have a built-in adjustable memory stop to eliminate rebalancing. Valves have FPT connections on both ends for connection to the water hose and to the field piping.

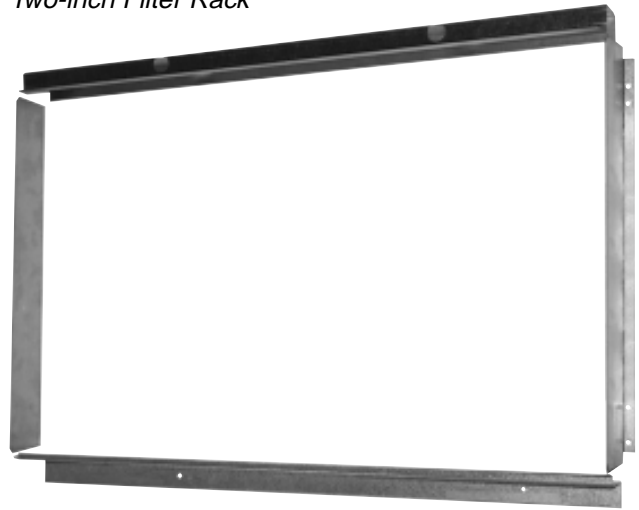
### *Shut off Ball Valve*



## Two-inch Filter Rack

Available as a field installed kit and provides a 1" (25 mm) deep collar for connection of return air ductwork. The kit also allows for a 2" (51 mm) thick filter. The kit consists of four sheet metal brackets and fasteners. The brackets replace the ones shipped with the unit and can be fastened to allow for side or bottom filter removal.

### *Two-inch Filter Rack*



## Motorized Valve

Used for variable pumping applications, the valve is wired in the compressor circuit and piped in the return water line from the unit. It opens when the compressor is on and closes when the compressor is off. The valve is rated for 300 psig (2070 kPa).

### *2-Way Motorized Valve*



## Boilerless System Kit

Eliminates the need for a boiler in the system water loop. The boilerless system control board senses the entering water temperature to the unit and locks out compressor heating operation if the water temperature falls below the adjustable setpoint. Contacts are provided to energize a field supplied electric heater downstream of the unit on a call for heating.

## Field Installed Controls

- A motorized valve relay and control valve assembly includes a relay, valve and wire harness. The valve opens when the compressor is on and closes when the compressor is off.
- A multiple unit control panel allows a single thermostat to control up to three units in parallel.
- An auxiliary relay controls optional devices when the fan is operating. The relay has SPDT contacts.

# Engineering Guide Specifications

---

Units shall be supplied completely factory assembled, piped, internally wired, fully charged with [HCFC-22 (sizes 007-012)] [HFC 410A (sizes 019-060)] and capable of operation with an entering water temperature range from [55°F to 110°F on models CCH] [25° to 110°F (-6.7°C to 49°C) on models CCW]. All equipment must be rated and certified in accordance with ARI/ISO 13256-1, UL, UL<sub>C</sub> and have correct ARI/ISO and UL<sub>C</sub> labels mounted on side of the cabinets. Each unit shall be fully run tested at the factory. The installing Contractor shall be responsible for furnishing and installing McQuay Water Source Heat Pumps as indicated on the plans.

## Casing and Cabinet

The cabinet shall be fabricated from heavy gauge G-60 galvanized sheet metal with interior surfaces lined with 1/2 inch thick, 1-1/2 lb. [coated glass fiber insulation] [closed-cell non-fibrous insulation]. The insulation shall have a flame spread of less than 25 and a smoke developed classification of less than 50 per ASTM E-84 and UL 723. All fiberglass shall be coated and have exposed edges tucked under flanges to prevent the introduction of glass fibers into the air stream. All insulation must meet NFPA 90A.

**Horizontal Units** shall be configured in one of the following airflow arrangements:

- Left Return/End Discharge
- Left Return/Straight Discharge
- Right Return/End Discharge
- Right Return/Straight Discharge

**Vertical Units** shall be configured in one of the following airflow arrangements:

- Left Return/Top Discharge
- Right Return/Top Discharge

Horizontal units must be capable of being field converted from side to end discharge (or the reverse) without unit modifications or additional parts. All units shall have a factory-installed 1" duct flange on the discharge of the blower and must have a minimum of two access panels to provide access to the compressor compartment and /one access to the blower compartment. Unit shall have an insulated panel separating the blower compartment from the compressor compartment. Units are to ship with heavy metal brackets, rubber isolators, fasteners and washers to suspend and isolate the unit from the building. The installing contractor is to fasten the hanging brackets in the field.

Cabinets shall have separate openings and knockouts for entrance of line voltage and low voltage control wiring. Supply and return water connections shall be brass FPT fittings and shall be securely mounted flush to the cabinet corner post allowing for connection to a flexible hose without the use of a back-up wrench. Unit shall have a plastic "dual-sloped" drain pan with a drain connection being flush mounted to the unit casing. It is the installing contractor's responsibility to provide sufficient clearance so that units can be easily removed for servicing.

## Filters

- Unit shall have a 1" (25 mm thick [throwaway] [30%]) filter and a factory-installed combination filter rack/return air duct collar. The filters shall be removable from the side or from the bottom.
- Unit shall have a 2" (51mm) thick [throwaway] [30%] filter and field-installed combination filter rack/return air duct collar. The bottom bracket shall be capable of being relocated for bottom filter removal.

## Refrigerant Circuit

Units shall have a sealed refrigerant circuit which includes a [rotary (sizes 007 to 012)] [reciprocating (sizes 019 to 024)] [scroll (sizes 030 to 060)] compressor, a thermostatic expansion valve, an aluminum fin and rifled copper tube refrigerant-to-air heat exchanger, a reversing valve and a water-to-refrigerant coaxial heat exchanger. The coaxial coils shall be made of [copper] [cupronickel] and shall be deeply fluted to enhance heat transfer and minimize fouling and scaling. The coil shall have a working pressure of 400 psig on the waterside of the unit, 500 psig on the refrigerant side for R-410A, and 400 psig on R-22 units.

# Engineering Guide Specifications

---

Refrigerant metering shall be regulated by a thermostatic expansion valve (TXV) only. Reversing valve shall be four-way solenoid activated refrigerant valve, which fails in the cooling “dominant” operation. Safety controls include a high-pressure switch, a low-pressure switch, and a low refrigerant temperature sensor. Refrigerant gauge access fittings shall be factory installed on high and low pressure refrigerant lines to facilitate field service. Activation of any safety switch shall prevent the compressor from operating. Units shall be capable of being reset only by interrupting the power supply to the unit. Unit shall not be able to be reset from the wall thermostat.

## Drain Pan

The condensate pan shall be constructed of high impact plastic to prevent corrosion and sweating. The bottom of the drain pan shall be sloped on two planes to provide complete drainage of water from the pan. The unit shall be supplied with a standard solid-state electronic condensate overflow protection.

**Fan and Motor Assembly** – Units 5 tons and smaller shall have a direct drive centrifugal fan. The fan housing shall have a removable orifice ring to facilitate fan motor and fan wheel removal. The fan housing shall protrude through the cabinet to facilitate field duct connection. The fan motor shall be a PSC type isolated from the fan housing and thermal overload protection. Units above one ton shall have a terminal strip mounted on the fan motor to facilitate motor speed change.

The fan and motor assembly must be capable of overcoming the external static pressures as shown on the schedule.

## Electrical

A control box shall be located within the unit and shall contain controls for compressor, reversing valve and fan motor operation and shall have a 50 VA transformer, circuit breaker in the low voltage circuit, and a terminal block for low voltage field wiring connections. Unit shall be nameplated to accept time delay fuses or HACR circuit breaker for branch overcurrent protection of the power source. Unit control system shall provide heating or cooling as required by the set points of the wall thermostat. The unit control scheme shall provide for fan operation simultaneous with compressor operation (fan interlock) regardless of the thermostat type. The unit shall be capable of providing an output signal to an LED on the thermostat or to a central monitoring panel to indicate a “fault” condition from the activation of any one of the safety switches.

## Solid-State Control System

**Mark IV/AC Control System** – Unit shall have a microprocessor-based control system. The unit control logic shall provide heating and cooling operation as required by the setpoints on the wall thermostat. The control system shall provide the following:

1. The use of standard mercury bulb type or programmable wall thermostats.
2. Fan operation simultaneous with the compressor (fan interlock) regardless of thermostat logic.
3. Time delay compressor operation.
4. Delayed de-energization of the reversing valve for quiet reversing valve operation.
5. Compressor short cycle protection of a minimum of three minutes before restart is possible.
6. Random unit startup after coming off on unoccupied mode.
7. Single grounded wire connection for activation of the unoccupied, load shed or unit shutdown modes.
8. Night setback temperature setpoint input signal from the wall thermostat.
9. Override signal from wall thermostat to override unoccupied mode for 2 hours.
10. Brownout protection to suspend unit operation if the supply voltage drops below 80% of normal.
11. Condensate overflow protection to suspend cooling operation in an event of a full drain pan.
12. Suspended compressor operation upon activation of the refrigerant pressure switch(es).
13. Cooling operation activated for 60 seconds upon activation of the low suction temperature (freezestat) switch - defrost cycle.
14. Method of defeating compressor, reversing valve and fan time delays for fast service diagnostics.
15. Remote reset of automatic lockouts.
16. Fault retry to minimize nuisance trips.

**MicroTech™ 2000 Control System** – Unit shall have a microprocessor-based control system. The unit control logic shall be LONMARK certified and shall be capable of communicating over a LONWORKS communications network. The unit controller is factory programmed and tested with all the logic required to monitor and control heating and cooling operation. The controller sets the unit mode of operation, monitors water and air temperatures, and can communicate fault conditions to a LONWORKS communications network. The MicroTech 2000 unit controllers include unit-mounted return air, discharge air and leaving water temperature sensors. Options include a wall sensor setpoint adjustment knob and tenant override button, and the capability of substituting the return air sensor with a wall-mounted room sensor.

# Engineering Guide Specifications

---

Each unit controller performs the following unit operations:

- Enable heating and cooling to maintain setpoint based on a room sensor.
- Enable fan and compressor operation.
- Monitor all safety controls.
- Monitor discharge air temperature.
- Monitor leaving water temperature.
- Relay status of all vital unit functions.
- Support optional control outputs.

An amber, on-board status LED aids in diagnostics by indicating the water source heat pump operating mode and alarm conditions. If there are no current alarm conditions, the LED will indicate the unit operating mode. If there are one or more alarm conditions present, the LED will flash to indicate an alarm condition. MicroTech 2000 heat pumps are designed to be linked with a centralized building automation system through a LONWORKS communications network for centralized scheduling and management of multiple heat pumps.

Wall-mounted room sensors are available to control the heating and cooling operation of each MicroTech 2000 Water Source Heat Pump Unit Controller. Available room sensors include: room sensor with LED status and tenant override button, room sensor with LED status, timed-override button, and bi-metal thermostat, room sensor with LED status, timed-override button, and setpoint adjustment, and room sensor with LED status, timed-override button, setpoint adjustment and bi-metal thermostat.

**BACnet® Control System** - Unit shall have a microprocessor- based control system. The unit control logic shall communicate over a native BACnet MS/TP communications network to a BACTalk® building automation system (BAS). The unit controller is factory programmed and tested with all the logic required to monitor and control heating and cooling operation. The controller operates the compressor, fan, and reversing valve as required to maintain the space temperature within the current setpoints. Data regarding equipment status, water and air temperatures, and fault conditions can be monitored by a native BACTalk BAS. Setpoints and other system preferences may be changed remotely using an Alerton BACTalk workstation or Alerton service tool software.

Each BACnet-compliant unit includes discharge air and leaving water temperature sensors, as well as all safety sensors, signals, and switches. Wall-mounted room sensors are available to control heating and cooling operation.

Each BACnet-compliant controller has the following operating features:

- Start-up
- Fan
- Cooling mode
- Heating
- Short Cycle Protection and Random Start
- Occupied
- Unoccupied
- After-hours Override
- Reversing valve delay
- Load Shed
- Brownout Protection
- Condensate Overflow Protection
- Safety
- Attained Temperature and Water Temperature Alarms
- Unit Self-test

Available sensors include tamper-resistant stainless steel wall sensors with optional push-button for status override; wall-mounted sensors with tenant setpoint adjustment lever and timed-override button; wall-mounted sensors with LED status, timed-override button, tenant setpoint adjustment buttons, password-protected field service access to operational data, and optional humidity sensor; and wall-mounted sensors with LCD and programmable operation.

# Engineering Guide Specifications

---

## Field Installed Accessories:

### Thermostat Options:

- Manual changeover wall thermostat** - for one-stage or two-stage heating and cooling operation. Sub-base shall have system “heat-off-cool” and fan “on-auto” switches.
- Deluxe automatic changeover wall thermostat** - for one stage heating, one stage cooling, one stage night setback heating operation 12°F (-6.6°C) below daytime heat setpoint and built-in override switch to activate the two-hour override function of the Mark IV board. Sub-base shall have system “off-auto” and fan “on-auto-(override)” switches with LED for “fault.”
- Automatic and manual changeover wall thermostat** – for one stage heating and one stage cooling operation. Sub-base shall have system “off-auto” and fan “on-auto” switches with LED for “fault.”
- Programmable wall thermostat** – for one stage heating, one stage cooling, night setup, night setback and day/night time clock operation. The thermostat shall have system “on-off,” temperature “heat-auto-cool” and fan “on-auto” switches.
- Non Programmable Electronic** – Premier white, mounts horizontal, system switch; Off-Heat-Auto-Cool and fan switch; On-Auto.
- 7-Day Programmable Electronic** – Premier white, for either two-stage cool or two stage heat pump and auto changeover operation. 7-day programming – program each day individually (four time/temperature changes) or program one day and copy the entire week. Auto or manual changeover, programmable fan, key pad lockout, adjustable deadband, integral four minute anti-short cycle protection. A remote wall sensor is available with this thermostat.

## Flexible Hoses:

Two fire rated flexible hoses with ASTM ratings of Flame Spread 25, Fuel Contribution 25 and Smoke Density 50 for connection to unit and field piping. Hose shall be covered with stainless steel.

**Valves** – Combination balancing and shutoff valve with adjustable memory stop.

## Automatic Flow Devices:

The automatic flow device kit shall be a Hays Mesurflo® automatic flow control valve, two ball valves, two flexible hoses, a high flow Y-strainer, and may include a strainer blow-down and various other accessories. The automatic flow control valve shall be factory set to a rated flow, and shall automatically control the flow to within 10% of the rated value over a 40 to 1 differential pressure, operating range (2 to 80 PSID). Operational temperature shall be rated from fluid freezing, to 225°F -. The valve body shall be constructed from hot forged brass UNS C37700 per ASTM B-283 latest revision.

## Field Installed Controls

- Motorized valve relay and control valve.** The assembly shall include a relay, valve and wire harness. The valve shall open when the compressor is on and close when the compressor is off.
- Multiple unit control panel** – allows a single thermostat to control up to three units in parallel.
- Auxiliary relay** – controls optional devices when the fan is operating. The relay shall have SPDT contacts.



# McQuay Water Source Heat Pumps Quality Products, Flexible Configurations



This document contains the most current product information as of this printing. For the most up-to-date product information, please go to [www.mcquay.com](http://www.mcquay.com).

McQuay International reserves the right to change design and specifications without notice in support of our policy of continuous product and data improvement.

<sup>TM</sup>The following are trademarks or registered trademarks of their respective companies: LonTalk from Echelon Corporation, BACnet from ASHRAE, Protocol Selectability, and MicroTech II from McQuay International.

